

# Transmitter unit for meter reading ENCO08 u. ENCO08-M



## OPERATING INSTRUCTIONS

Reliable Measurement of Gas



Status: 2018, September 10th  
Version: 05

## Kontakt

---

**Manufacturer** Our customer service is available for technical queries

<b>Address</b>	RMG Messtechnik GmbH Otto-Hahn-Straße 5 D-35510 Butzbach
<b>Phone switchboard</b>	+49 6033 897 – 0
<b>Phone service</b>	+49 6033 897 – 0
<b>Phone spare parts</b>	+49 6033 897 – 173
<b>Fax</b>	+49 6033 897 – 130
<b>E-mail</b>	<a href="mailto:service@rmg.com">service@rmg.com</a>

**Original Document** The **ENCO08M\_manual\_05\_en** from 2018, September 10th for the transmitter unit ENCO08 u. ENCO08-M is the document translated first from the German original version. Anyhow, this document may serve as reference for translations into other languages. Please use in case of any uncertainties the German version as main reference.

**Note** Unfortunately, paper is not updated automatically, whereas technical development continuously advances. Therefore, we reserve the right to make technical changes in regard to the representations and specifications of these operating instructions. The latest version of this manual (and other devices) can be downloaded at your convenience from our Internet home-page

[www.rmg.com](http://www.rmg.com).

<b>Date created</b>	2018, September 10th
<b>1<sup>st</sup> revision date</b>	

<b>Document version and language</b>	<b>Document Version</b>	ENCO08M_manual_05_en 2018, September 10th
	<b>Language</b>	EN

---

# Contents

<b>1</b>	<b>Introduction.....</b>	<b>1</b>	
1.1	Structure of the manual.....	1	I
1.2	Objective of the manual.....	1	
1.2.1	Abbreviations.....	2	
1.2.2	Symbols .....	2	
1.2.3	Layout of instructions.....	2	
1.2.4	Using the encoder.....	3	
1.2.5	Risk assessment and mitigation .....	7	
1.2.6	Validity of the manual .....	8	
1.2.7	Transportation.....	10	
1.2.8	Delivery .....	10	
1.2.9	Dispose of packaging material .....	11	
1.2.10	Storage.....	11	
1.3	Explosion-proof design .....	11	
1.3.1	General information.....	11	
1.3.2	Junction boxes with enhanced safety .....	12	
1.4	Inspection and maintenance work.....	13	
1.4.1	General information.....	13	
<b>2</b>	<b>Encoder ENCO 08 and ENCO 08-M.....</b>	<b>14</b>	
2.1	Preface.....	14	
2.2	Operation .....	15	
2.3	Function .....	16	
2.4	Variants .....	17	
2.4.1	ENCO 08.....	17	
2.4.2	ENCO 08-M .....	18	
2.5	Use in custody transfer applications .....	20	
2.5.1	Sealing plan .....	21	
<b>3</b>	<b>Connection and commissioning .....</b>	<b>24</b>	
3.1	General .....	24	
3.2	Electrical Data.....	25	
3.3	Electrical connections .....	26	
3.4	Data protocol.....	27	



## Contents

---

<b>3.5</b>	<b>Putting into operation .....</b>	<b>28</b>
3.5.1	ENCO 08 .....	28
3.5.2	ENCO 08-M .....	28
3.5.3	Connecting the gas flow.....	30
	<b>Appendix .....</b>	<b>31</b>
	<b>Appendix A: connection example.....</b>	<b>31</b>
	<b>Appendix B: certificates / standards.....</b>	<b>32</b>

# 1 Introduction

## 1.1 Structure of the manual

The introduction to this manual consists of three main parts. In the first part of the introduction, general guidelines are listed; here the symbols used and the structure of notes are presented, but also a risk assessment is given. It also contains specifications for the transport and storage of the ENCO 08 encoder.

ENCO 08 may be operated in hazardous areas. The second part of the introduction deals with the conditions to be observed and describes this hazardous area.

The third part of the introduction describes mandatory, regular inspection and maintenance work.

The second chapter describes the function and intended use of ENCO 08. The third chapter describes the connection and commissioning.

The appendix contains the connection examples to a flow computer and a list of approvals.

## 1.2 Objective of the manual

This manual provides information necessary for trouble-free and safe operation. The ENCO 08 encoder was designed and manufactured in accordance with the state of the art and recognized safety standards and guidelines. Nevertheless, dangers can occur during its use which can be avoided by observing these instructions. You may only use the ENCO 08 encoder for its intended purpose and in a technically perfect condition.

### **Caution**

**If the encoder ENCO 08 is not used for its intended purpose, all warranty claims expire and the encoder may lose its approvals.**

## 1 Introduction

### 1.2.1 Abbreviations

The following abbreviations are used:

ca.	circa, approximately
max.	maximum
min.	minimum
MID	Measurement Instruments Directive

### 1.2.2 Symbols

The following symbols are used:

1, 2, ...	Marks steps within a work operation
..	

### 1.2.3 Layout of instructions

The following instructions are used:

 <b>Danger</b>
<p><b>This warning instruction informs you of potentially hazardous situations that can occur as a result of incorrect operation or human error. If these situations are not avoided, they can lead to fatal or severest injuries</b></p>

 <b>Caution</b>
<p><b>This warning instruction informs you of possible hazardous situations that can occur as a result of incorrect operation or human error. If these situations are not avoided, they can lead to slight or minor injuries.</b></p>

**Notice**

**This warning instruction informs you of potentially hazardous situations that can occur as a result of incorrect operation or human error. If these situations are not avoided, they can result in material damage to the device or the vicinity.**

**This notice may also give to you tips on how to simplify your work. With this screen, you additionally receive further information on the device or the work process.**

3

## 1.2.4 Using the encoder

### 1.2.4.1 Safety instructions

The ENCO 08 encoder complies with current standards and regulations. Nevertheless, operating errors can cause hazards.

** Danger**

**Observe the following safety instructions!**

Non-observance of these safety instructions can lead to a risk of life and limb and health of the person as well as damage to the environment or property damage.

Note that the safety instructions in this operating instruction and on the device cannot cover all possible hazardous situations as the combination of different circumstances is impossible to predict. To simply follow the instructions specified may not normally be sufficient enough to ensure for correct operation. Always be observant and also consider the following:

- Before working with the device for the first time, read through this operating instruction and, in particular, follow the safety instructions carefully.
- The operating instruction warns against the residual risks for users, third parties, devices or other material assets. The safety instructions used refer to residual risks that cannot be avoided due to the design.
- Operate the device only in a sound state and when observing the operating instruction.
- Also observe the local legal accident prevention, installation and assembly guidelines.

### **Caution**

All notes in the manual must be observed.

Always keep the operating instructions within reach for use at the place of installation.

For safe operation, the safety instructions must be observed and followed.

The manufacturer is not responsible for any damage that result as a consequence of not observing the operating instruction.

### **Danger**

Service and maintenance work or repairs that are not described in the operating instruction must not be carried out without previous consultation with the manufacturer.

Changes of the Encoder ENCO 08 are forbidden.

#### 1.2.4.2 Hazards during commissioning

Initial start up

Initial start-up must only be carried out by especially trained personal (training by RMG) or by service personal from RMG.



### **Notice**

In accordance with §15 BetrSichV "Betriebssicherheitsverordnung (industrial safety ordinance)", §5 DGUV Requirement 3 "Elektrische Anlagen und Betriebsmittel (electrical systems and equipment)" and the generally accepted rules of technology, especially VDE standards VDE 0100-100 "Errichten von Niederspannungsanlagen (building of low-voltage systems)" and VDE 0165 "Electrical explosion protection", the measuring system must be checked before commissioning the device.

Follow local or regional laws as appropriate.

An acceptance test certificate and corresponding test reports must be prepared for this commissioning. These, the operating instructions and the CE declaration of conformity must always be kept handy. All documentation, including declarations of conformity and certificates, must be checked for completeness.



 <b>Danger</b>	
	<p><b>This symbol in the manual warns you of the danger of explosion; follow the instructions next to the symbol.</b></p>

Particular attention must be paid to the risk of explosion:

- Install the device TRZ03 in accordance with operating instructions. If the TRZ03 is not installed according to the manual, there is possibly an insufficient explosion protection.

### The explosion protection expires!

- When staff carry out work without sufficient qualification, risks remain understated when working. Explosion or fire may happen. Perform the work only if you have the appropriate qualifications and you are an expert.
- If you do not use the appropriate tools and materials, components may be damaged. Use tools that are recommended to you for the job in the operating instructions.

Mechanical installation	Mechanical installation must only be carried out by the respectively qualified specialist personnel.
Electrical installation	Installation on components must only be carried out by qualified electricians.
Mechanical and/or electrical installation	The specialist personnel require a training especially for working in potentially explosive environment. Specialist personnel are persons that can verify a training / further education according to <b>DIN VDE 0105, IEC 364</b> or a <b>similar national standard</b> .

 <b>Danger</b>	
<p><b>The installation of pressurized pipes must be carried out exclusively by trained specialist personnel.</b></p>	

## 1 Introduction

Since the operation of the ENCO 08 encoder does not have to do directly, but only indirectly, with pressurized pipelines, no further warnings in this respect are listed here. If necessary, contact the operator of the plant for further information.

Notice:

- The ENCO 08 encoder may only be connected in an explosion-free, depressured atmosphere. Observe the descriptions in the operating instructions during the installation process.
- In general, it is recommended that an ENCO 08 encoder should only be installed, connected or replaced by RMG Service.
- All the above points also apply to repair and maintenance work and generally when connecting or disconnecting the ENCO 08 encoder is required.

### 1.2.4.3 Danger when using, servicing and maintaining

Operating personnel	The operating personnel are to use and operate the device within the scope of the intended purpose.
Maintenance personnel	Work on the device must only be carried out by specialist personnel that can carry out the respective work assigned to them as a result of their training, knowledge and experience as well as the applicable regulations. These specialist personnel are familiar with the legal guidelines for accident prevention and can evaluate and avoid possible risks by themselves.
Maintaining and cleaning	Maintenance and cleaning must only be carried out by the respectively qualified specialist personnel.

#### **Danger**

**If staff carry out work without sufficient qualification, risks may be underestimated when working. Explosion or fire may happen. If work is carried out in hazardous areas on voltage supporting equipment, resulting sparks may cause an explosion.**

**Only carry out the work if you have the appropriate qualifications and are a trained specialist.**

### **Caution**

If the unit is not cleaned in accordance with the operating instructions, the device may be damaged. Clean the unit only in accordance with the operating instructions.

**Clean with a damp cloth!**

7

### **Danger**

**The Encoder ENCO 08 may only be used as intended!**  
(*chapter 2 Encoder ENCO 08 and ENCO 08-M*).

**Avoid any use of the Encoder ENCO 08 as possible climbing aid or attachments of Encoder ENCO 08 as possible handholds!**

#### 1.2.4.4 Qualification of personnel

Persons working with or on the device must have the following knowledge:

- Training / education for working in potentially explosive environments.
- The ability to correctly assess dangers and risks when using the ENCO 08 encoder and all connected devices. Possible hazards include components under pressure or the consequences of incorrect installation.
- Possible dangers are, e.g., components under pressure or the result of incorrect installation.
- Recognize dangers that could be caused by the used flow medium.
- Training / education by RMG for working with gas measuring instruments.
- Education / instruction in all country-specific standards and directives to be observed for work that is to be carried out on the device.

#### 1.2.5 Risk assessment and mitigation

The TRZ03 subjects to risks in its use, which were judged by qualified staff of the company RMG. Risks can arise, for example, from work outside the permissible temperature range. Illegal current and voltage values can cause explosions in hazardous areas. Of course only work by trained personnel (*chapter 1.2.4.4 Qualification of personnel*) are permitted, which is also trained to know proper tools and use only this.

## 1 Introduction

These risks have been considered during the development phase and action were taken to minimize these risks.

 **Danger**



**Working in hazardous areas**

8

For work in hazardous areas (all zones):

- Only tools approved for Ex Zone 1 may be used for maintenance and repair work. Components can be damaged if you do not use the appropriate tool.

### **The explosion protection expires**

- Otherwise work may only be carried out if there is no potentially explosive atmosphere.
- A risk of ignition caused by impact or friction must be avoided.
- In hazardous areas, the wiring and installation of the ENCO 08 encoder may only be carried out by trained personnel in accordance with EN60079-14 and in compliance with national regulations.
- Qualified personnel are persons according to DIN VDE 0105 or IEC 364 or directly comparable standards
- Only use trained and instructed personnel. Work on the measuring system may only be carried out by qualified persons and must be checked by responsible specialists.
- Qualified persons have been authorized to carry out such work by the person responsible for the safety of man and plant on the basis of their training, experience or instruction and their knowledge of relevant standards, regulations, accident regulations and plant conditions. It is crucial that these persons are able to recognize and avoid possible dangers in good time.

### **1.2.6 Validity of the manual**

This manual describes the transmitter unit ENCO08 u. ENCO08-M. This encoder is only a part of a complete on-site system. Observe also the instructions of other components of the site system. If you find contradicting instructions, please contact RMG.

 <b>Caution</b>
<p><b>Make sure that the electrical data of the power connection correspond to the specifications on the type plate. Care of any other applicable national regulations in the country of use. Use cables suitable for the cable glands (see <i>chapter 3 Connection and commissioning</i>)</b></p>

**1.2.6.1 Hazards during Operation**

Please take care of the information provided by the plant manufacturer and/or plant manager.

**1.2.6.2 Danger during operation in hazardous areas**

 <b>Danger</b>
<p><b>Use the encoder ENCO 08 only in the original condition.</b></p>

- Only operate the encoder ENCO 08 in perfect and complete condition. If you make technical changes to the device, safe operation can no longer be guaranteed.
- When connecting further measuring components or additional equipment in hazardous areas, make sure that the appropriate explosion protection is available for these components.
- If the devices are intrinsically safe, galvanic isolation must be provided when these devices are connected.

The encoder ENCO 08 may be operated in Ex-zone 1, but only within the permitted temperatures (*chapter 1.3 Explosion-proof design*)

**1.2.6.3 Operator responsibility**

Take care as plant manager that only sufficiently skilled personnel will work on the device. Ensure that all employees who handle the equipment have read and understood these instructions. Additionally, you are obliged to train staff on a regular basis and to inform them about any dangers. Ensure that any work carried out on the device is done by qualified personnel and checked by responsible specialists. You must establish clearly the responsibilities for installation,

## 1 Introduction

operation, troubleshooting, maintenance and cleaning. Point out to your staff any risks involved when using the device.

For all work on ENCO 08, suitable personal protective equipment must be used, which you as the operator must provide. This applies although all sharp edges have been removed from the device as far as possible.

10

### 1.2.7 Transportation

The device is packaged customized according to the transport requirements. For each subsequent transport, ensure safe packaging that absorbs shocks and vibrations. Nevertheless, advise the transporter to avoid possible shocks and vibrations during transport.

The following applies in particular during transport:

- Avoid shocks and vibrations
- Protect ENCO 08 from humidity
- In case of suspicion of improper transport or damage during transport, please contact RMG service immediately.

### 1.2.8 Delivery

Supplied number of parts may differ depending on the optional customer order. "Usually" the following is included in the scope of delivery:

Part	Quantity
Encoder ENCO 08	1
Manual	1

no CD is supplied with the integrated ENCO 08

or

Encoder ENCO 08-M	1
CD (with the operating software)	1
Programming module (optional)	1
...	

## 1.2.9 Dispose of packaging material

Dispose the packing material in an environmentally friendly way in accordance to the national standards.

### 1.2.10 Storage

Avoid long periods of storage. Check the Encoder ENCO 08 after any storage for damage and functionality. Ask for a check from the RMG service after a storage period for the device of over one year. In this case please send back the device to RMG.

Nevertheless, if storage is necessary, the following must be observed:

- A dry, frost-free environment is required for storage.
- Installation and commissioning must be carried out exclusively by qualified personnel

## 1.3 Explosion-proof design

### 1.3.1 General information

#### **Danger**

The encoder ENCO 08 may be installed in hazardous areas in zone 1, as long as only gases and vapors are present which are assigned to explosion group IIC and temperature class T6.

**ATEX – Approval number: BVS 15 ATEX E 041 X**

Indication:



**II 2G Ex ib IIC T6**

The device complies with the regulations of Directive 94/9/EC.

The applicable regulations must always be observed during installation and operation. The permitted electrical data can be found in chapter 3.3 *Electrical connections*.

### **Danger**

Risk of destruction by body electricity, e.g. due to friction of clothing - appropriate protective clothing must be worn.

### **Notice**

During installation, it must be ensured that the enclosure protection class is observed. Direct sunlight must be avoided.

The encoder housing complies with protection class IP20 due to EN 60529 and is installed in a totalizer housing (e.g. totalizer head G) or an aluminum housing (ENCO 08-M) with a protection class of IP66 + IP67.

## Temperature ranges

### **MID:**

-25°C to +55°C (ambient Temperature, custody transfer)

### **ATEX:**

-40°C to +57°C (T6)

### **Notice**

In case of doubt, the limited range of the MID applies: -25°C to +55°C

## 1.3.2 Junction boxes with enhanced safety

### **Danger**

When connecting the device electrically, make sure that the power supply is correct (see data on the type plate).



## 1.4 Inspection and maintenance work

### 1.4.1 General information

Explosion-proof electrical control units must be regularly maintained. The time intervals of this maintenance depend on the operating and environmental conditions.

13

#### Notice

**We recommend at least one check per year (e.g. in connection with the annual calibration).**

In principle, ENCO 08 is maintenance-free.

#### **Danger**

**Work on live electrical equipment is generally prohibited in hazardous areas (except for intrinsically safe circuits).**

In special cases, work can also be carried out on live electrical equipment in hazardous areas if it is ensured that no potentially explosive atmosphere is present. This may only be done with explosion-proof, approved measuring instruments.

#### **Danger**

**If access to electrical modules is necessary, the following precautions must be taken:**

- **The entire device must be disconnected from the power supply.**
- **When working with electronic assemblies, a connection must be established between an earthed object and the body.**

If the device is repaired regarding a part which depends on explosion protection, it may only be put back into operation after it has been checked by a certified expert (*section 1.2.4.4 Qualification of personnel*).

If repairs are carried out by RMG service, no acceptance by an expert is required.

## 2 Encoder ENCO 08 and ENCO 08-M

### 2.1 Preface

In addition to the traditional transmission of volume information by electrical pulses, where the number of pulses is proportional to the volume at measuring conditions flowing through the meter, digital transmission of meter readings is getting more and more important.

With the transmitter unit **ENCO 08** (integrated transmitter unit in totalizer F and G) and **ENCO 08-M** (external transmitter unit in totalizers with mechanical output drives), it is possible to transfer the meter reading digitally to a volume corrector.

This is an energy self-sufficient encoder, which operates as a magnetic "absolute encoder" in continuous operation without any external power supply.

The encoder ENCO 08 is used for the custody transfer of mechanical totalizer readings (Vo) and for compliance with the legal metrological requirements with regard to the recording of measured values.

The counter reading and all other application-specific device values are stored in the microcontroller and cannot be lost. The meter reading is output via the NAMUR interface (EZD protocol).

ENCO 08 is parameterized by means of an operating software (e.g. "Set meter reading"). This is done by RMG Messtechnik upon delivery, so the customer does not have to carry out any further parameter adjustments on site during commissioning (exception: ENCO 08-M).

## 2.2 Operation

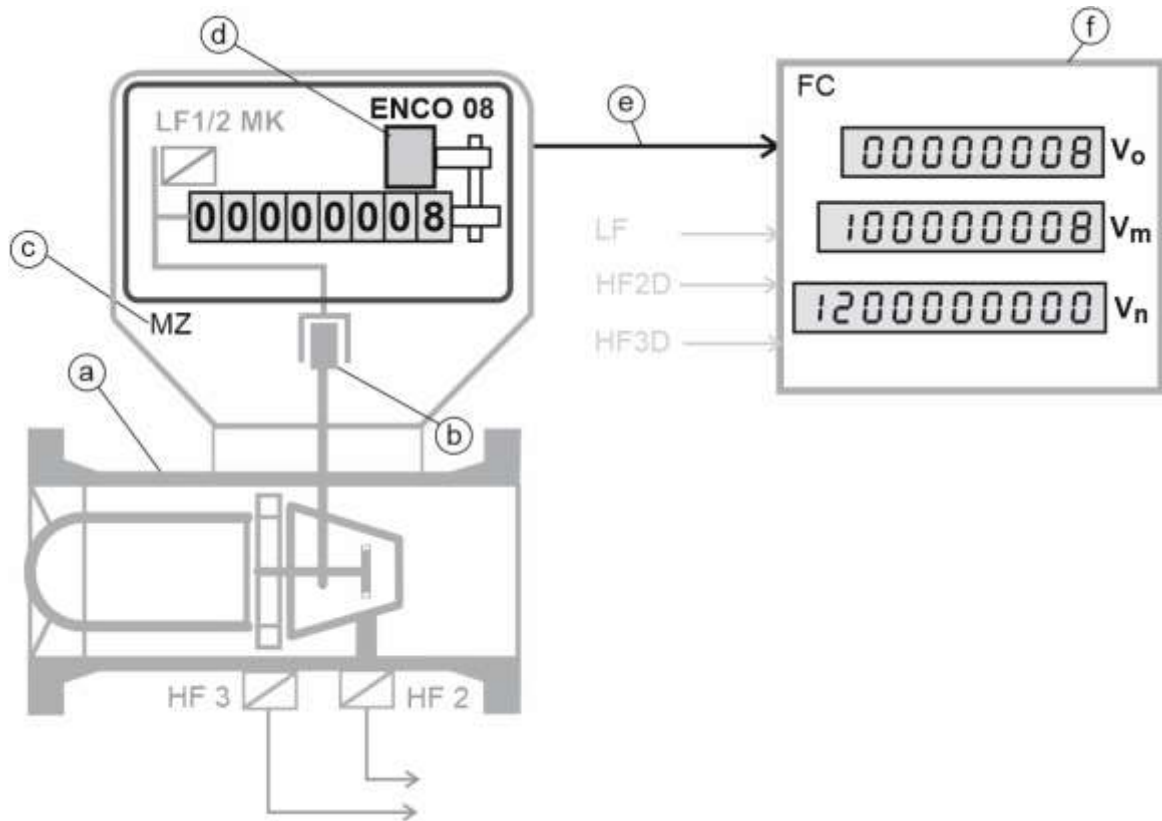

Remark: Usually the totalizer housing is significantly smaller than the turbine

- (a) gas meter (turbine)
- (b) magnetic coupling
- (c) MZ mechanical counter
- (d) encoder ENCO 08, transmitter unit for meter reading
- (e) connection for data transmission
- (f) flow computer

$V_o$  volume counter (original counter reading)  
 $V_m$  volume at measurement conditions  
 $V_n$  volume at standard conditions

2 x LF, HF2D, HF2D pulse generator, 1 channel [Namur, Reed]

LF Low frequency  
 HF High frequency

## 2.3 Function

The ENCO 08 is coupled to the totalizer via a gear wheel. When the mechanical counter rotates, the rotation is transferred to the encoder shaft in the ENCO 08. Voltage pulses are induced in the Wiegand sensor module under the impact of the now rotating magnetic field. These signals are evaluated in the electronic module and converted into an electronic meter reading.

The energy required for displaying and permanent storing of the meter reading is generated by the internal Wiegand sensors. Therefore, no external power supply (battery) is required to record the meter reading. As soon as a converter is connected, it also provides the necessary power supply for digital transmission (EZD protocol) of the meter reading.

The hardware consists of Wiegand sensors with energy generation (Wiegand sensor module), counting logic (ASIC and Hall sensor) and counter reading archive (FRAM counter).

All application-specific parameters are stored in the EEPROM of the microcontroller and cannot be lost.

## 2.4 Variants

### 2.4.1 ENCO 08

Integrated in the totalizer head type F (for TRZ 03, TRZ 03-K)

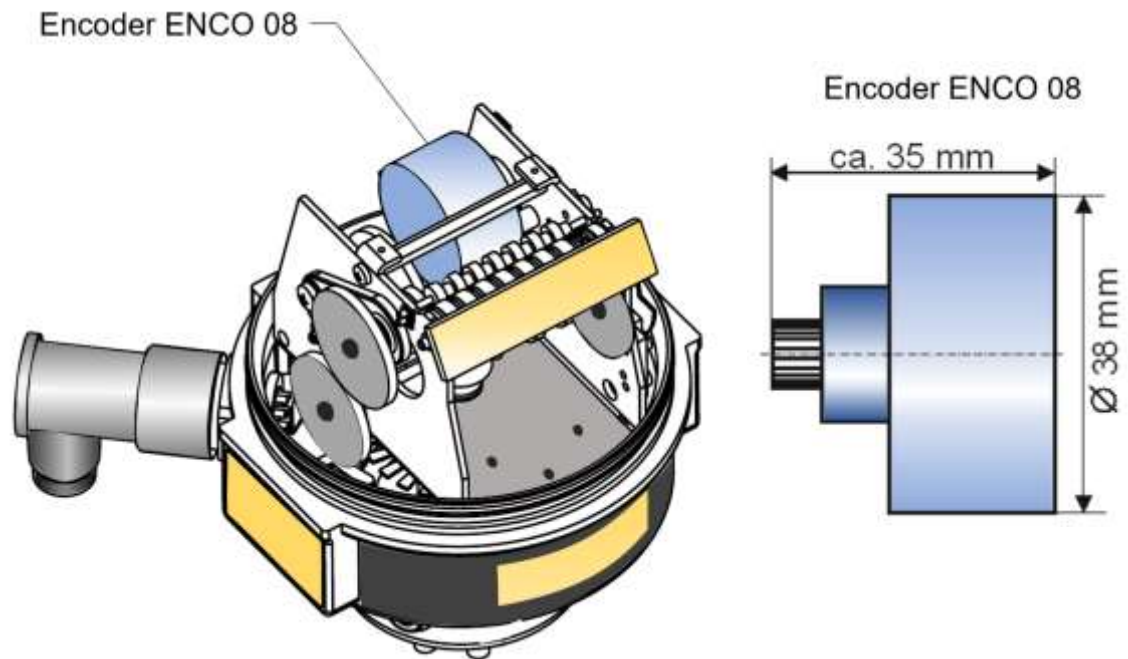

17

Integrated in the totalizer head type G (for TRZ 04, TRZ 04-K and DKZ 02)

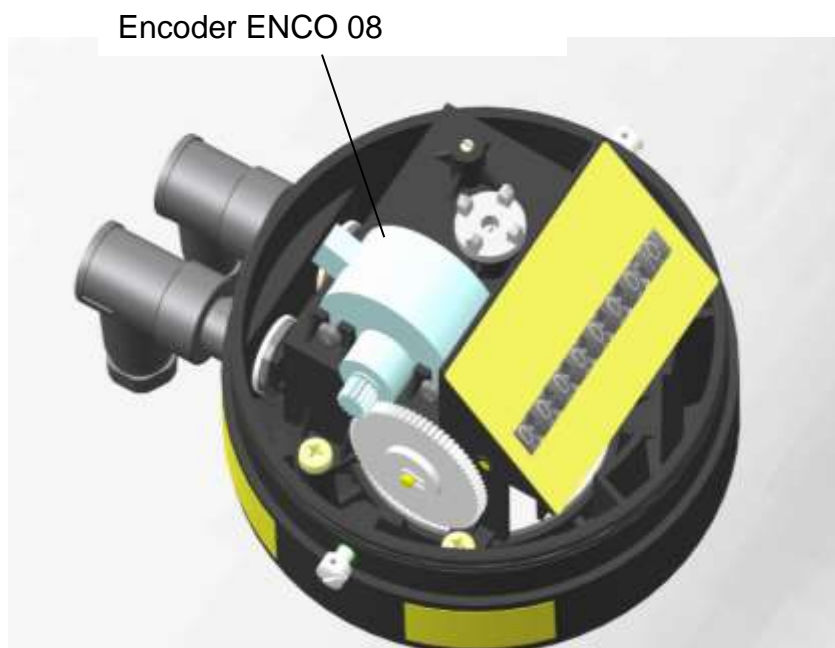

### 2.4.2 ENCO 08-M

External encoder for mounting on mechanical counters with mechanical output according to EN12261.

18

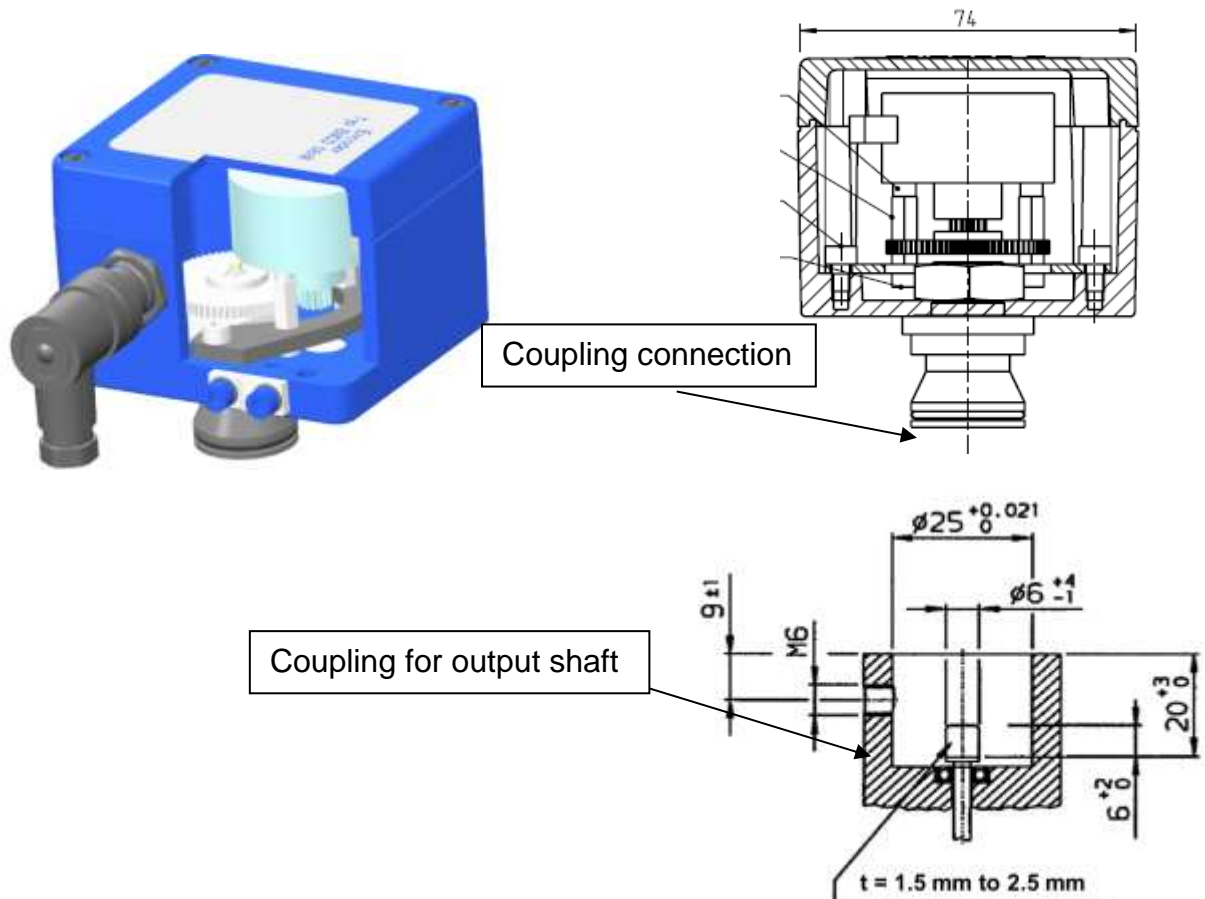

This version requires on-site parameterization, unless the ENCO08-M is already mounted and sealed in a totalizer head with mechanical output.

The ENCO 08-M is parameterized with its specific data (such as meter reading, number of decimals and direction of rotation) by means of a PC operating program to the meter type to which it is attached.

With the ENCO 08 firmware (1.11 and 1.12), turbine and rotary displacement meters can be operated with the following combinations of output value (Ua) and number of decimals (NKS – Nachkommastellen, German):

	U <sub>a</sub> = ... m <sup>3</sup> , (Specification on mechanical output)				
NKS	0.01	0.1	1	10	100
3	1.12	-	-	-	-
2	1.12	1.11 1.12	-	-	-
1	-	1.12	1.11 1.12	-	-
0	-	-	1.12	1.11 1.12	-
x10	-	-	-	1.12	1.11 1.12

1.11: Standard for ENCO08 / ENCO08-M for **8-digit counters**

1.12: ENCO08-M with special output ratio and **9-digit counters**

1.12: ENCO08-M with special output ratio and **8- and 9-digit counters**

### Note

#### Important

The output values must be specified when ordering. If these values are not available, the ENCO08-M is set to the default values:

- U<sub>a</sub> = 0,1m<sup>3</sup>
- NKS = 1
- SW = 1.12
- Direction of rotation = clockwise

## 2.5 Use in custody transfer applications

This chapter contains information on how you can upgrade the ENCO08-M for custody transfer and ensure its use here. For this purpose, seals are attached at various points of the ENCO08-M and the housing is sealed to prevent opening.

20



### Caution

**The ENCO08-M is approved for custody transfer. It is sealed before delivery and certain settings are locked by the approval authority.**

**These seals must not be damaged, destroyed or removed!**

**In this case, the ENCO 08 loses the calibration certification!**

**The ENCO 08 can only be re-certified for the in custody transfer applications by an officially approved certification lab or an calibration official and an additional check of the settings. The calibration officer must reattach the seals after his verification and calibration.**

**The re-equipping for custody transfer is usually associated with costs**



2.5.1 Sealing plan

2.5.1.1 Type plate

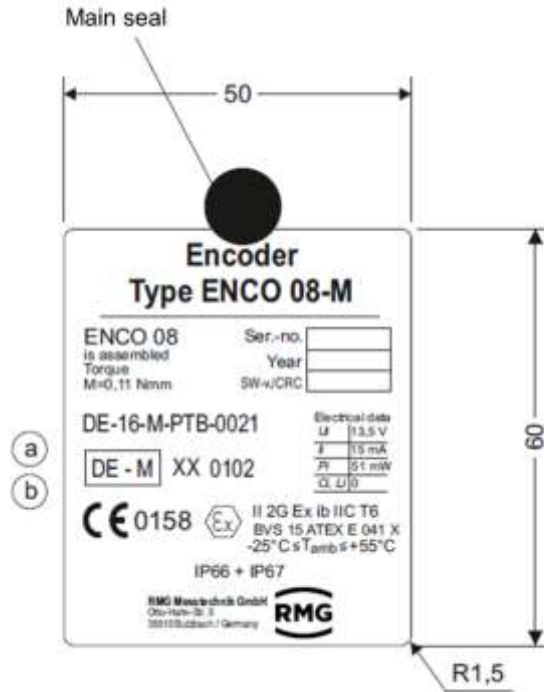

**Notice**

The modification of parameters or the software (of the internal firmware) is only possible after a seal break and by using a PC and a programming module.

**⚠ Caution**

If the software version is replaced, the type plate must be replaced, too.

## 2 Encoder ENCO 08 and ENCO 08-M

### 2.5.1.2 Seals on the housing

In the following figures, the positions at the encoder ENCO 08 are marked that must be sealed to prevent opening.

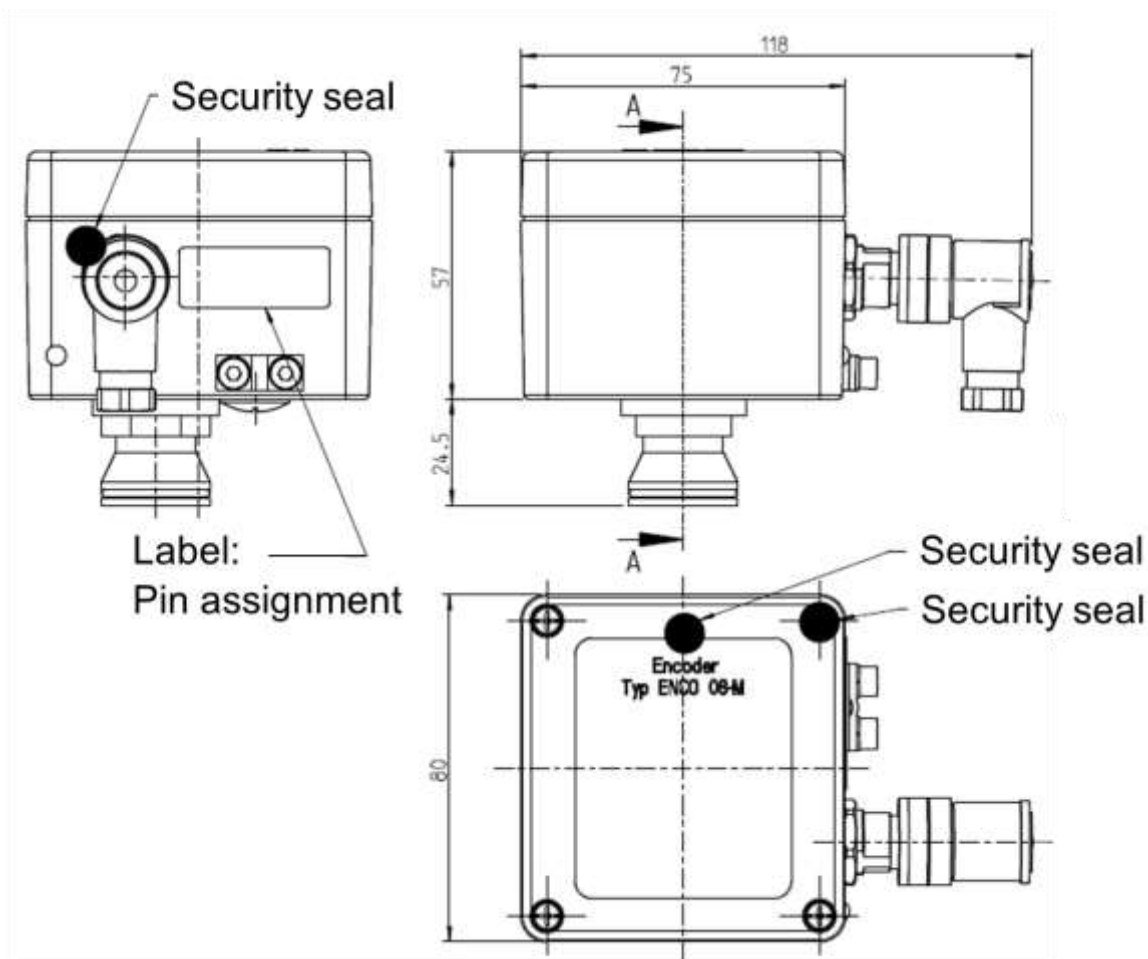

The digital, custody transfer of the  $V_0$  to a transmitter device is in accordance to DIN 19234 respectively NAMUR. This is unidirectional and interaction-free.

#### Notice

**The cable between the ENCO08-M and the transmitter device must be sealed.**

2.5.1.3 Coupling for the output shaft

**Notice**

The mechanical output of the ENCO08-M must be sealed, too.

**Front view**

**View rotated 90°  
sectional view**

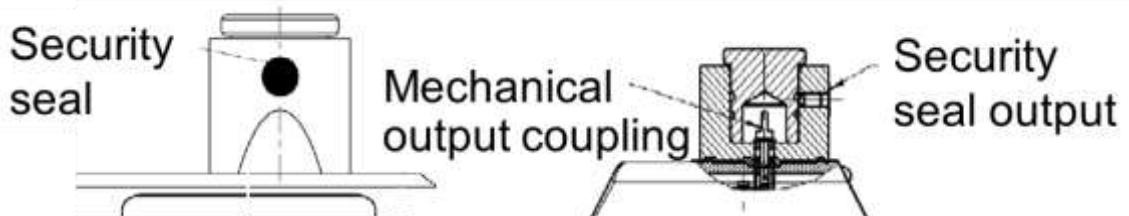

# 3 Connection and commissioning

## 3.1 General

When selecting the cable, make sure that the permitted maximal values are taken into account according to the EC type examination certificate.

The electrical Ex network must be realized with its own cable. Only a shielded cable may be used for the installation of the encoder; we recommend the cable LIYCY 2 x 0.75 mm<sup>2</sup>, sheath color blue.

The cable screen is connected on both sides. The shield is grounded on the non-hazardous supply side. At the other end of the cable, the shield is connected on the insulated metal housing of ENCO 08. The housing of ENCO 08 may also be earthed in potentially hazardous area, observing the regulations according to DIN EN 60079-14. The meter housings of turbine gas meters and rotary displacement meters as well as the aluminum housing of the ENCO 08-M must be earthed.

A stable installation of the intrinsically safe cables is absolutely necessary. The connection cables must be equipped with wire end ferrules.

## 3.2 Electrical Data

Label:	Type: ENCO 08
Voltage $U_i$ :	13,5 V
Current $I_i$ :	15 mA
Power $P_i$ :	51 mW
C <sub>i</sub> :	neglectable
L <sub>i</sub> :	neglectable

---

---

---

---

---

---

25

The device complies with the following regulations and standards:

- ATEX guideline: 2014/34/EU
- EN 60079-0
- EN 60079-11
- EN 60079-14
- EMV guideline: 2014/30/EU
- OIML R137-1&2
- OIML D11
- Digital interface for primary devices with transmission of the meter readings
- EN 60947-5-6

The applicable regulations and directives must always be observed during installation and operation.

### 3.3 Electrical connections

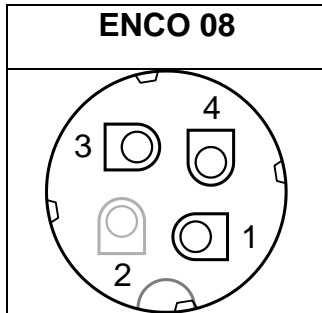

Contact	
1	Vo +
2	-
3	Vo -
4	PE

The connection of the digital signal Vo is realized via the sockets 1 and 3.

### 3.4 Data protocol

The electronically recorded totalizer reading is transmitted in a data protocol "Digital interface for primary devices with meter reading transmission" in specified time intervals.

A two-wire interface according to EN 60947-5-6 (NAMUR threshold level specification) serves as the hardware layer for power supply during the data transmission.

The additional bidirectional interfaces on the ENCO 08 are only available in the service mode and enable operation, parameterization and flashing of the firmware in the factory or during maintenance work on site.

 **Danger**

**Intrinsic safe operation is not guaranteed during the use of these interfaces!**

It must be ensured that no hazardous area is created during maintenance work!

A connection example to the ERZ2000-NG can be found in the appendix:  
*Appendix A: connection example*

## 3.5 Putting into operation

### 3.5.1 ENCO 08

This version (integrated in totalizer heads F and G) **does not require a local parameterization**. The ENCO 08 is preset to the meter type with its specific data, tested and sealed at the RMG factory by the certified test lab using the user software.

During commissioning on site, only the connection (see connection examples) between ENCO 08 and the connected readout device must be established. The connection for the encoder is located on the back of the totalizer head (a plug from the company Binder of the series 713: 1 = Vo + // 3 = Vo -).

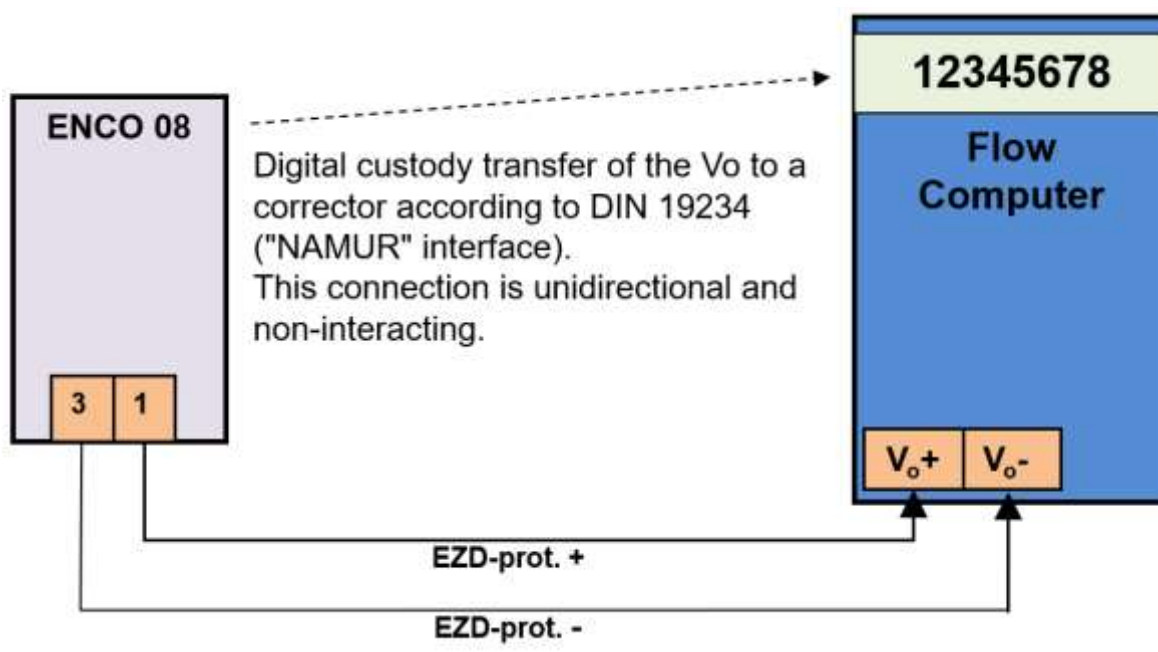

### 3.5.2 ENCO 08-M

This version (external encoder) requires local parameterization. The ENCO 08-M must be parameterized to its specific data for the meter type to which it is attached (such as meter reading, decimal digits and direction of rotation) by means of the user software. This separate manual "ENCO 08 - Programming Manual" can be found in the help menu of the "ENCO08 PC Software". Here you will also find a short manual for this "ENCO08 PC Software".

The ENCO 08-M can be used without restriction on all RMG turbine meters and rotary displacement meters with mechanical output. The ENCO08-M can also be



mounted on all manufacturer-independent turbine and rotary displacement gas meters with mechanical output and a maximum of 9-digit roller counter, whereby for 8 rollers, the last scale division corresponds to the 9th digit.

The ENCO 08 programming module and the PC-ENCO user program (software) are required for parameter setting. This separate quick guide can be found in the help menu of the "ENCO08 PC Software".

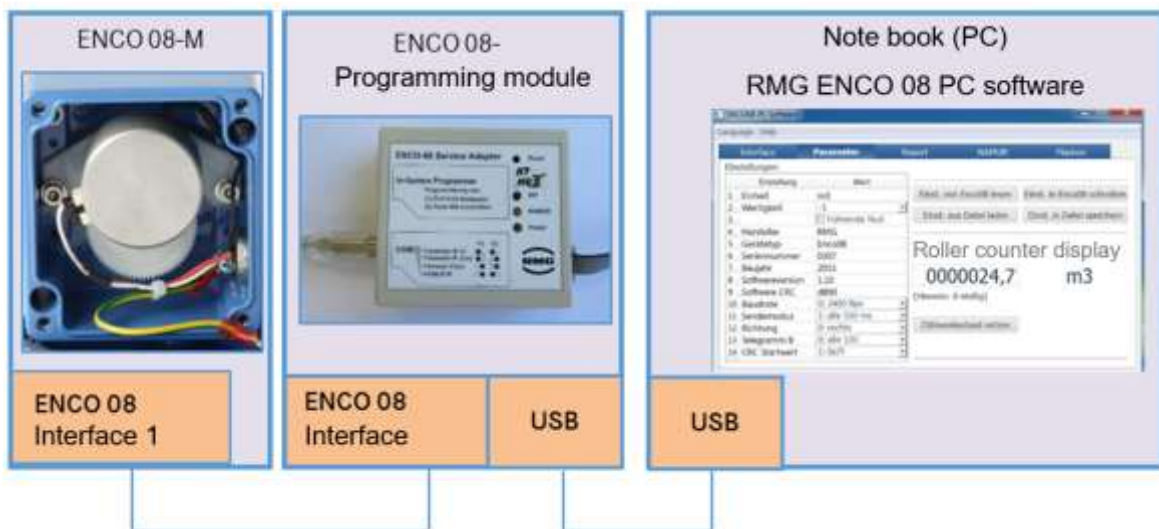

When putting into operation on site, the connection (see connection examples) between ENCO 08-M and the connected readout device must still be established after the programming has been completed. On the housing side there is the connection for the encoder (plug from the company Binder of series 713).

## 3 Connection and commissioning

---

### 3.5.3 Connecting the gas flow

Please observe the operating instructions of the gas meter! The following applies to RMG turbine meters:

**⚠ Caution**

**Do not operate any downstream pipelines or system components through the turbine meter. Turbine rotation can occur that may lead to excessive stress or overload and cause damage.**

A short overload of 20% above the maximum flow rate  $Q_{\max}$  is permitted. In case of a smooth backflow, no damage occurs.

# Appendix

## Appendix A: connection example

### Connection scheme to the flow computer ERZ 2000(-NG; -Di, ..)

When using the internal Ex separating stage, terminals X9 are assigned on the ERZ:

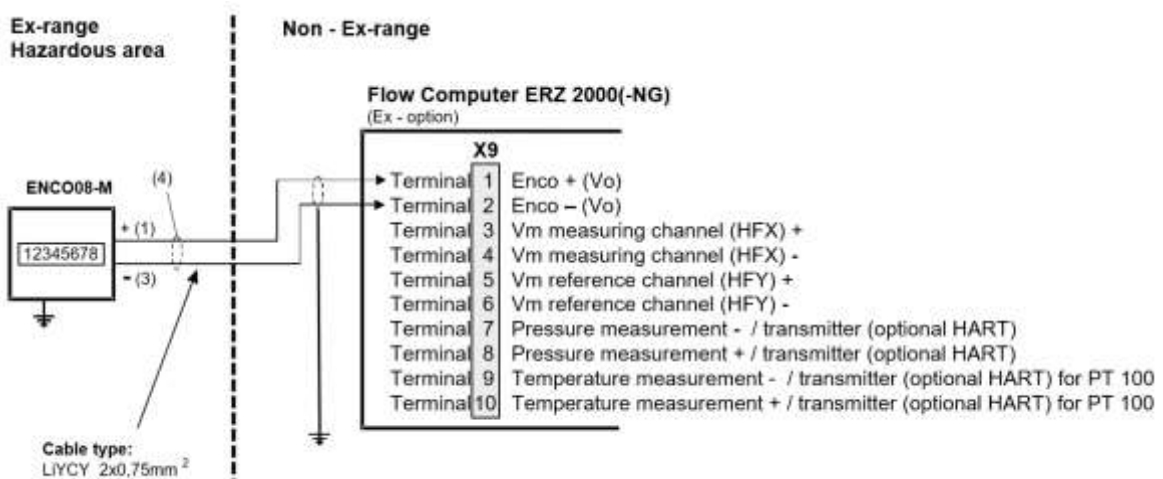

When used without internal Ex separating stage, terminals X4 are assigned on the ERZ:

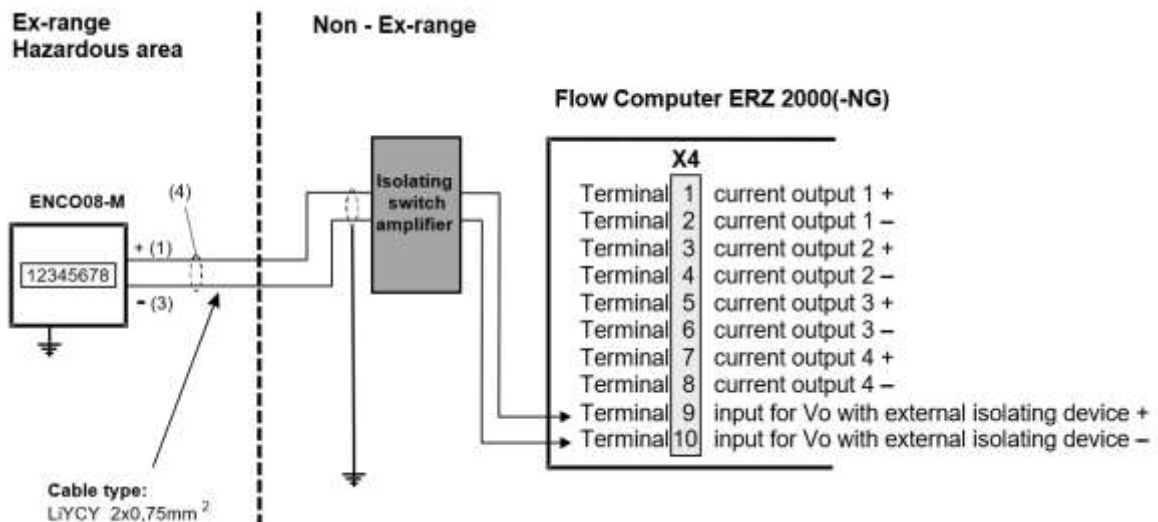

---

## Appendix B: certificates / standards

**ENCO 08 (-M) has the following approvals, which are listed below:**

- Type examination certificate

### **Metrologic approval**

- Certificate of Conformity according OIML R137-1 (2012), EN12261: + A1, EN12480 + A1 (NMI: CoC-15200211-01)

### **Ex-approval**

- ATEX according EN60079-11, EN60079-0 + A11 (BVS 15 ATEX E 041 X)
- Labeling: II 2G Ex ib IIC T6

- **EU-Declaration of Conformity**

- **Declaration of Conformity due to MessEG**



## Kontakt

---

*Subject to technical modification*

**For further information**

please visit our website:

[www.rmg.com](http://www.rmg.com)

or contact your local sales support office  
to learn more about the RMG products.

**RMG Messtechnik GmbH**

Otto-Hahn-Straße 5  
35510 Butzbach, Deutschland  
Tel: +49 (0) 6033 897 – 0  
Fax: +49 (0) 6033 897 – 130  
Email: [service@rmg.com](mailto:service@rmg.com)

