



Operating Manual

Gas Analyzer QS 400-F

Status: December 7th, 2020
Version: 04

Distributor Contact our customer service department for technical information.

Address	RMG Messtechnik GmbH Otto-Hahn-Straße 5 D-35510 Butzbach (Germany)
Main office	+49 6033 897 – 0
Service	+49 6033 897 – 0
Spare parts	+49 6033 897 – 173
Fax	+49 6033 897 – 130
Email	service@rmg.com

Manufacturer	Address	Mems AG Bruggerstrasse 30 CH-5413 Birmenstorf
	Phone	+41 56 470 92 00
	Fax	+41 56 470 92 09
	Email	info@mems.ch

Translation of the original document The **GQS400-F_manual_en_04** for the gas analyzer QQS 400-F from October 2nd, 2019 is a translation of the original German manual. Anyhow, this document may serve as reference for translations into other languages.

Remark Please use in case of any uncertainties the German version as main reference

Note Unfortunately, paper is not updated automatically, whereas technical development continuously advances. Therefore, we reserve the right to make technical changes in regard to the representations and specifications of these operating instructions. The latest version of this manual (and the one other devices) can be downloaded at your convenience from our Internet page:

www.rmg.com

Created	December 2018
1st Revision	January 2019
2nd Revision	May 2019
2nd Revision	October 2nd, 2019

Document version and language	Document version	GQS400-F_manual_en_04 October 2nd, 2019
	Language	EN

Contents

1	ABOUT THIS MANUAL.....	1
1.1	General considerations.....	1
1.1.1	Abbreviations.....	1
1.1.2	Symbols.....	2
1.1.3	Structure of notices	2
1.1.4	Working with the device	3
1.1.5	Risk assessment and minimization	7
1.1.6	Applicability of the manual.....	7
1.1.7	Transport.....	8
1.1.8	Scope of delivery.....	9
1.1.9	Disposal of packaging material	10
1.1.10	Storage.....	10
1.2	Structure of the manual	11
1.3	Function.....	11
1.4	Certification for Hazardous Areas.....	16
1.5	Maintenance.....	18
2	TAKING INTO OPERATION	20
2.1	Electrical connection.....	24
2.1.1	Required material	24
2.1.2	<i>Optional material</i>	24
2.1.3	Connections	24
2.1.4	Mechanical interface	25
3	OPERATION.....	30
4	TROUBLESHOOTING.....	32
5	TECHNICAL DATA	33
5.1	Electrical Parameter	33
5.2	Pressure Parameter.....	33
5.3	Operating Temperature	34
5.4	Measured media.....	34
	APPENDIX	35
	Appendix A: Name plates	35
	Appendix B: Connection GQS 400-F to an ERZ2000-NG.....	38

Appendix C: Junction box for the GQS 400-F	45
Appendix C: Certificates	46
Appendix D: Modbus specifications.....	51

1 About this manual

1.1 General considerations

This manual provides information that is necessary for fault-free and safe operation.

The gas analyzer QQS 400-F was designed and produced according to the state of the art and generally recognized safety standards and directives. However, its use can entail dangers that are avoidable by complying with this manual. The gas analyzer QQS 400-F must only be used as intended and in technically sound condition.

⚠ Warning	
Unintended use voids all warranty claims and the gas analyzer QQS 400-F can also lose its approvals.	

1.1.1 Abbreviations

The following abbreviations are used:

ca.	circa, about
max.	maximum
min.	minimum
e.g.	for example
MID	Measurement Instruments Directive
PED (DGRL)	Pressure Equipment Directive (Druckgeräterichtlinie)
DSfG	Digitale Schnittstelle für Gasmessgeräte Digital interface for gas flow rate meters, created under the umbrella of the DVGW
DVGW	Deutscher Verein des Gas- und Wasserfaches German Gas and Water Association
MessEG	Measuring and calibration law Law on placing and providing measuring instruments on the market, their use and calibration; valid since 1.1.2015

MessEV	Measuring and calibration regulations Regulation on placing and providing measuring instruments on the market; their use and verification; 11.12.2014
PTB	Physikalisch-Technische Bundesanstalt German authority for calibration tasks

2

1.1.2 Symbols

The following symbols are used:

1, 2, ...	Identifies steps for work tasks
..	

1.1.3 Structure of notices

The following notices are used:

 Danger
<p>This warning notice informs you of imminently threatening dangers that can arise due to misuse/operator error. If these situations are not avoided, death or severe injuries can occur.</p>

 Warning
<p>This warning notice informs you of potentially dangerous situations that can arise due to misuse/operator error. If these situations are not avoided, minor injuries can occur.</p>

 Caution
<p>This notice informs you of potentially dangerous situations that can arise due to misuse/operator error. If these situations are not avoided, damage to the device or nearby property can occur.</p>

Note
<p>This notice informs you of potentially dangerous situations that can arise due to misuse/operator error. If these situations are not avoided, damage to the device or nearby property can occur.</p> <p>This notice can provide you with helpful tips to make your work easier. This notice also provides you with further information about the device or the work process in order to prevent operator error.</p>

3

1.1.4 Working with the device

1.1.4.1 Safety notices Danger, Warning, Caution and Note

⚠ Danger
<p>All of the following safety notices must be observed!</p> <p>Disregard of the safety notices can result in danger to the life and limb or environmental and property damage.</p>

Bear in mind that the safety warnings in this manual and on the device cannot cover all potentially dangerous situations, because the interaction of various conditions can be impossible to foresee. Merely following the instructions may not suffice for correct operation. Always remain attentive and consider potential consequences.

- Read this operating manual and especially the following safety notices carefully before working with the device for the first time.
- Warnings are provided in the operating manual for unavoidable residual risks for users, third parties, equipment or other property. The safety instructions used in this manual do not refer to unavoidable residual risks.
- Only operate the device in fault-free condition and in observance of the operating manual.
- Compliance with local statutory accident prevention, installation and assembly regulations is also mandatory.

Note

All notices in the manual must be observed.

Use of the GQS 400-F is only permitted in accordance with the specifications in the operating manual.

RMG assumes no liability for damages arising due to disregard of the operating manual.

⚠ Danger

The GQS 400-F complies with current standards and regulations. However, danger can arise with misuse and the GQS 400-F can be destroyed due to operator error.

The technical specifications must be observed and followed for safe operation (*Chapter 5 Technical data*). Performance limits must not be exceeded.

For safe operation, the GQS 400-F must only be used in the scope of the intended use. (*Chapter 1.3 Function*)

Service and maintenance tasks or repairs that are not described in the operating manual must not be carried out without prior consultation with the RMG.

1.1.4.2 Dangers during commissioning**Note**

An acceptance test certificate must be created during the commissioning. This, the operating manual and the CE Declaration of Conformity must be stored so that they are always readily available.

All sharp edges on the device were removed, insofar as possible. However, suitable personal protective equipment provided by the operator must be worn during all work.

Danger

This symbol is used in the manual as a warning of the danger of explosion; observe the instructions following the symbol. With the danger of explosion, the following must be observed, in particular:

The GQS 400-F is approved to be used in hazardous areas.

Observe the information given in the applicable type examination certificate and the relevant country-specific regulations for installation and use in hazardous areas (e.g. IEC 60079-10, IEC 60079-14, IEC 60079-20).

No observance can result in serious injury and/or damage to the equipment.

Install the device as specified in the operating manual. If the device is not installed as specified in the operating manual, there may be a risk that other connected devices doesn't have adequate explosion protection.

Improper installation can lead to the loss of the explosion protection and to life-threatening situations.

5

1.1.4.3 Dangers during maintenance and repair

Operating personnel	The operating personnel use and operate the device in the scope of the intended use.
Maintenance personnel	Work on the device must only be carried out by qualified personnel who can carry out the respective tasks on the basis of their technical training, experience and familiarity with the applicable standards and requirements. These qualified personnel are familiar with the applicable statutory regulations for accident prevention and can independently recognize and avoid potential dangers.
Maintenance and cleaning	Maintenance and cleaning must only be performed by appropriately qualified technicians.

⚠ Danger

The device can be damaged if it is not cleaned as specified in the operating manual. Only clean the device as specified in the operating manual.

Components can be damaged if you do not use suitable tools.

- Only clean the device with a slightly damp cloth!

1.1.4.4 Qualification of personnel**Note**

In general, the following is recommended for all persons working with or on the GQS 400-F:

Training / education for work in hazardous areas.

The capacity to be able to correctly estimate dangers and risks when working with the GQS 400-F and all connected devices.

Training / education by RMG for work with gas measuring devices.

Education / instruction in all national standards and directives to be complied with for the work to be carried out on the GQS 400-F.

⚠ Danger

For work, i.e. mechanical and/or electrical installation of the measuring system, in particular during initial commissioning, only trained and instructed personnel are permitted to work in potentially explosive areas. The work must be checked by responsible specialists. The mechanical installation may only be carried out by suitably qualified technicians.

1.1.4.5 Responsibility of the operator

As the operator, you must ensure that only adequately qualified personnel work on the device. Ensure that all employees who work with the device have read and understood this manual. You are also obligated to train personnel regularly and inform them of the dangers. Ensure that all work on the device is carried out exclusively by qualified persons and inspected by responsible qualified supervisors. The

responsibilities for installation, operation, fault rectification, maintenance and cleaning must be clearly regulated. Instruct your personnel with regard to the risks involved with working with the device.

1.1.5 Risk assessment and minimization

7

According to assessment by qualified employees, the GQS 400-F is subject to risks during its use. Risks can arise, for instance, during use outside of the permissible temperature range. Impermissible current and voltage values can trigger explosions in explosion-prone areas. Naturally, work must only be carried out by trained personnel (see *chapter 1.1.4.4 Qualification of personnel*), who are also trained to recognize suitable tools and use them exclusively. These risks were summarized alongside development and measures were taken to minimize these risks.

1.1.6 Applicability of the manual

This manual describes the GQS 400-F. The GQS 400-F is only part of a complete system. The manuals of the other components of the system must be observed. If you find contradictory instructions, contact RMG and/or the manufacturers of the other components.

Note

Ensure that the power data of the current connection matches the specifications on the type plate. Observe any applicable national regulations in the country of use. Use cable that is appropriate for the cable fittings.

1.1.6.1 Danger during operation

Observe the specifications of the system manufacturer and/or system operator.

1.1.6.2 Dangers of operation in EX areas

The GQS 400-F is intended for use in hazardous areas. If you make technical changes to the device, safe operation can no longer be guaranteed.

Danger

- Only use the GQS 400-F in its original, complete and fault-free condition.
- When connecting additional equipment in hazardous areas, ensure that the appropriate explosion protection is provided for these components.
- The GQS 400-F is an intrinsically safe device for which galvanic isolation for the connection must be provided.
- Do not use this instrument in safety or emergency stop systems. Incorrect use of the instrument can result in serious injury.

1.1.7 Transport

The assembled gas quality instrument is packaged specific to the transport requirements for each customer; including preassembled sealing and protection cap(s). Ensure safe packaging that absorbs light impact and vibrations is used for any further transport. Nevertheless, inform the transport company that all types of impact and vibrations should be avoided during transport.

Note

Protection caps are enclosed to prevent internal damage or pollution to the instrument during transport and storage. Remove the protection caps only just before installing the instrument to minimise risk of pollution. Keep the protective caps in a safe place so that they can be used again in the event of further transport.

1.1.8 Scope of delivery

The scope of delivery can differ depending on the optional orders. The following is “normally” included in the scope of delivery:

Part	Quantity
Gas analyzer GQS 400-F	1
Power supply	1
Fixing plate	1
M12 power supply cable	1
M12 communication cable	1
Termination resistor	1
M12 Y divider	1
Zener barrier (optional)	2
Manual	1
...	...

Note

The above list applies to the GQS 400-FT.

For the GQS 400-FS variant, the parts listed are mounted / integrated on a mounting plate; this of course does not apply to the power supply and the Zener barriers, which cannot be placed in hazardous areas.

Optionally, the mounting plate with all accessories can be installed in a protective housing. This variant contains a heater with automatic temperature control.

As an option, the entire structure in the protective housing can also be supplied with a pedestal.

Further information on the two variants can be found in *chapter 1.3 Function*.

1.1.9 Disposal of packaging material

Dispose of instrument components and packaging materials in an environmentally friendly manner in accordance with the respective waste treatment and national disposal regulations and standards of the region or country to which the instrument is supplied.

Note

Keep the packaging, as it offers optimal protection during transportation (e.g. changing installation location, shipment for repair).

1.1.10 Storage

Avoid extended periods of storage. Inspect the gas analyzer GQS 400-F for damage and correct function after storage. Contact the RMG service department to arrange for inspection of the device after a storage period of longer than one year. For this purpose, send the device to RMG.

1.2 Structure of the manual

The introduction of this manual comprises several parts. The first part lists general specifications; the symbols used in the manual and the structure of notices are presented and a risk assessment is provided. It also includes specifications for transport and storage of the gas analyzer GQS 400-F. The second part describes the setting up of the manual. The third part describes the operation mode of the GQS 400-F and its intended purpose. Certification and maintenance are the last sections of chapter one.

The second chapter explains how the device is electrical connected. Taking the device into operation is explained in the third chapter. The fourth chapter gives advice in case of trouble.

Chapter five summarizes the technical specifications.

The Appendix provides the name plates and the certificates of the gas analyzer GQS 400-F.

1.3 Function

The GQS 400-F is a microelectromechanical gas quality measurement device. Based on its CMOS chip microthermal flow sensor in combination with a sonic nozzle and two on/off valves, thermal conductivity, heat capacity and relative density of natural gas are measured. From these parameters, calorific value or Wobbe index are correlated.

Compared to process gas chromatographs, the typical analytical tool to determine gas parameters, this standalone device needs no carrier gas, is robust, compact and inexpensive. It also provides a control output for automatic calibration in the field.

The gas quality measuring device GQS 400-F is an in-house development of Mems AG and is produced by this company in Switzerland. The gasQS™ technology is the intellectual property of Mems AG and has been a protected trademark since 2014. RMG Messtechnik GmbH sells these devices, installs them on various mounting plates and connects them correctly. These different variants are listed below.

Versions of the gas analyzer family GQS 400-F family:

- **Device with mounting plate: GQS 400-FS**
Wall installation in the protection cabinet and high pressure reduction

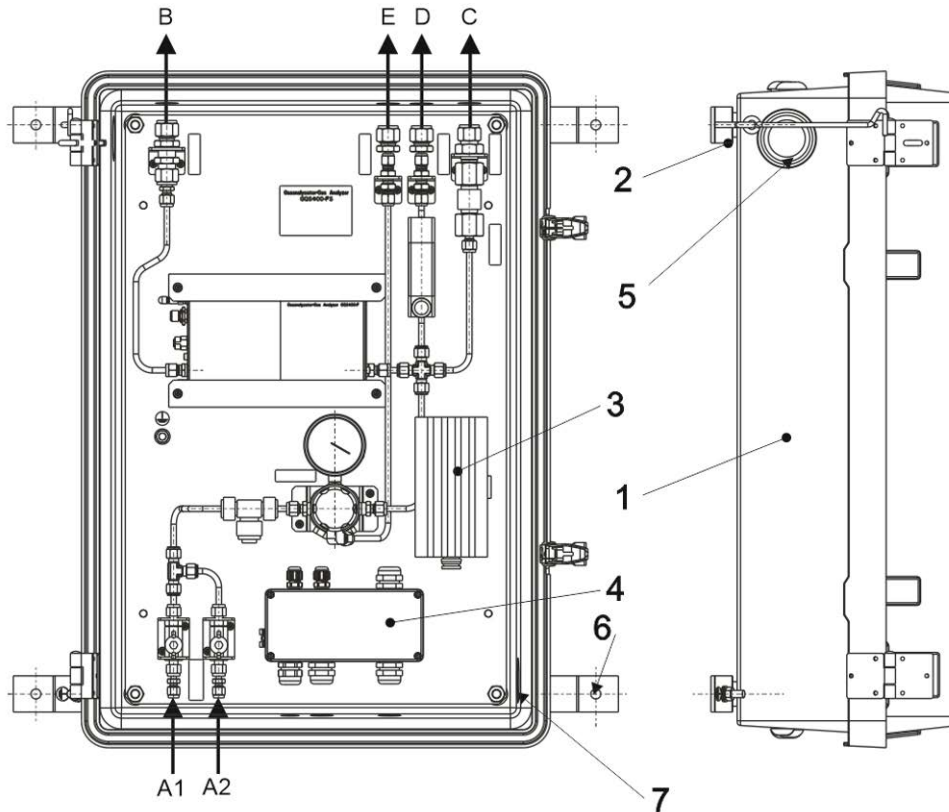

- 1.) Isolation cabinet with window door hinge left
- 2.) Holder for wall installation
- 4.) Ex (e)(i) – connection box for gas analyzer and heating
- 5.) Ventilation
- 6.) Hole Ø 11 mm
- 7.) Aeration

Options:

- A2. 2. Gas inlet
- 3.) Heating (Ex) 100 W with integrated thermostat in connection cable (fixed value temperature 10°)

Tube for connections A1,A2:

Standard: 6 mm tube
 Options: 1/8" tube, 4 mm tube.
 Customer connections in Swagelok system (Stainless-steel)

Standard connections:

- B. Gas outlet (in the air) (12 mm pipe)
- C. Vent line of relief valve (12 mm tube)
- D. Vent line bypass (12 mm tube)
- E. Vent line regulator (12 mm tube)

Figure 1: GQS 400-FS

There are 3 other variants that are very similar to the one shown in *Figure 1: GQS 400-FS*; they are therefore not shown separately here. If required, please contact

RMG's sales or service department who will be happy to send you a suitable drawing. Further variants are:

- Device with mounting plate: Wall installation in the protection cabinet and fine pressure reduction
- Device with mounting plate: Wall installation without protection cabinet with high pressure reduction
- Device with mounting plate: Wall installation without protection cabinet with fine pressure reduction

Figure 2: Photo GQS 400-FS with fine pressure reduction with fine pressure control shows the GQS 400-FS on the mounting plate without protection cabinet with fine pressure reduction.



Figure 2: Photo GQS 400-FS with fine pressure reduction

Figure 3: manifold connections shows the manifold connections, a heater (in the protective box) is connected in the factory on the right above the manifold, it is mounted in the position of the 6 holes. The customer only connects the digital interface on the left side of the distribution box.

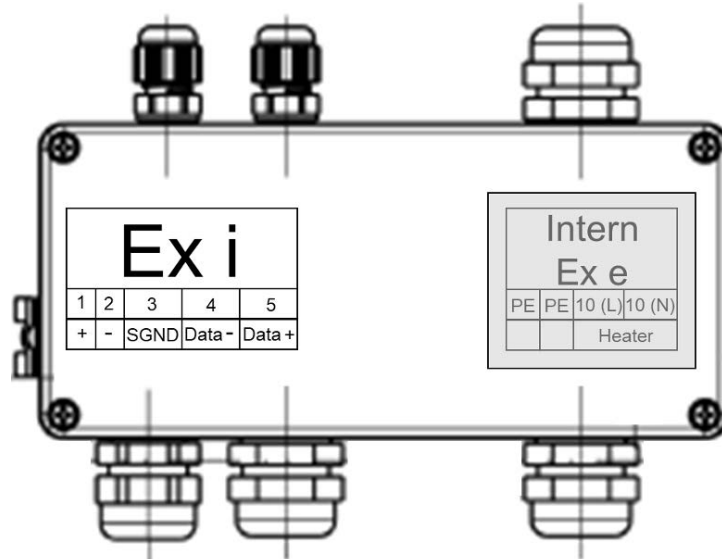

Figure 3: manifold connections

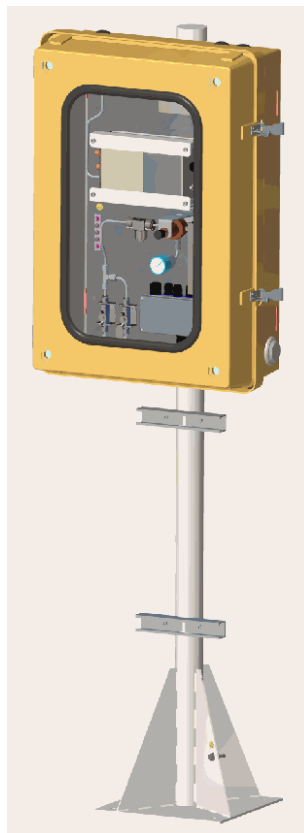
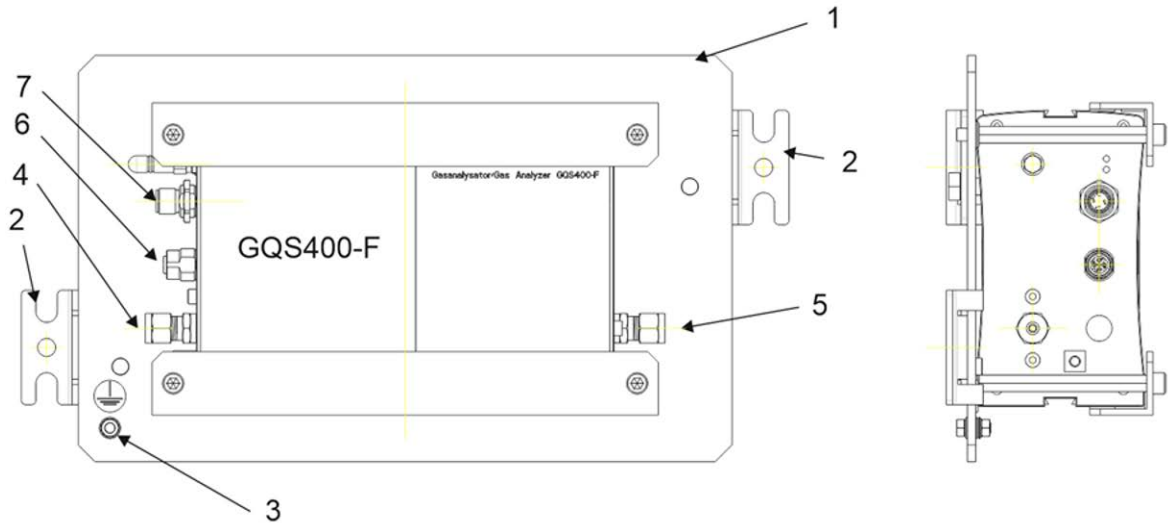

Figure 4: GQS 400-FS with pedestal

- Device without mounting plate: **GQS 400-FT**



- | | | | |
|---|----------------------------|---|----------------------|
| 1 | Fixing plate | 5 | Gas inlet |
| 2 | Mounting for wall mounting | 6 | Communication socket |
| 3 | Ground | 7 | Power supply |
| 4 | Gas outlet | | |

Figure 5: GQS 400-FT

Note

Nomenclature:

Mounting plate is only the plate on which other components are integrated (see Figure 1: GQS 400-FS).

The fixing plate (position 1 in Figure 5: GQS 400-FT) is not called mounting plate.

1.4 Certification for Hazardous Areas

The GQS 400-F is certified for Zone 1 applications. To cover additional customer requirements the instrument reaches Zone 0 standard. Please contact RMG for additional information.

Danger

In accordance with the ATEX regulations (IEC60079) electrical connections **MUST** be conducted through separate Zener barriers.

Otherwise the GQS 400-F is not suitable for operation inside explosive atmospheres. The barrier protects the instrument from interferences of the supply and control system.

Please take into account the different Ex zones 0, 1 and 2.

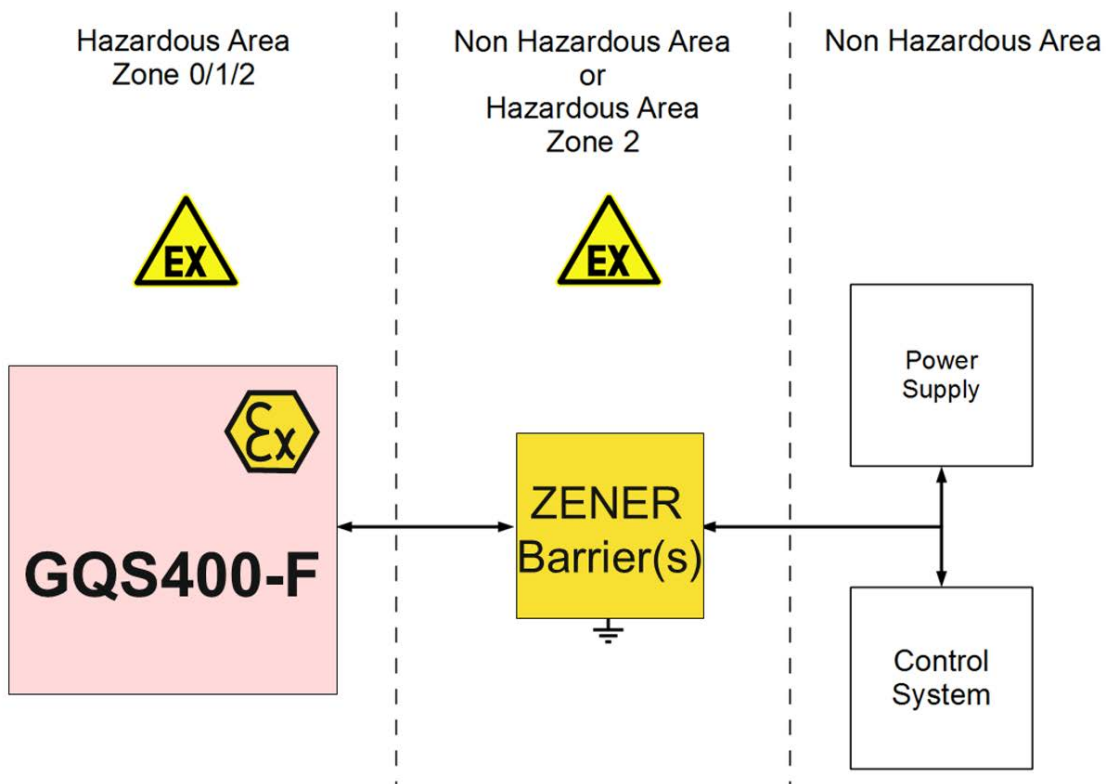

Figure 6: Zonal structure of GQS 400-F application

The GQS 400-F is approved for the use in explosive areas; the indication is:

1.5 Maintenance

Danger

Power Off

Do NOT separate the device when its energized.

Power supply must be switched off and disconnected at main before cleaning or repair.

Danger

Do NOT open pressurized connections. Open pressurized connections only after the pressure of the system or the appropriate section has been released to atmospheric level.

Danger

Escaping gas can lead to serious injury. In event of failure, components can be ejected at elevated speed or gas exhausted under high pressure.

Open the connections only after the system has been depressurised.

Ensure that the pressure in the system as a whole cannot exceed the lowest maximum pressure of any of its components. If variations of the pressure level or different pressure levels are to be expected in the system, components must be used that can withstand the maximum expected pressure levels and peaks.

Observe the working conditions in accordance with GQS 400-F datasheet.

Actions or alterations to the gas quality instrument, which are not described in these operating instructions, are not permitted.

Ensure that the mounting point has been made absolutely free from burrs and is clean.

After installation, use a gas leak detector sensitive to the used gas to ensure that there is no leak.

⚠ Danger

For hazardous media such as flammable gases, in addition to all standard regulations, the appropriate existing codes or regulations must also be followed.

Reduce the risk of creating hazardous areas by controlling and monitoring the gas release in relation to the properties of the specific media (e.g. IEC 60079-20).

19

Note

At normal use, no routine maintenance is required to be performed on the instrument. For further information contact RMG. Have repairs performed by RMG only to prevent losing warranty claim.

Note

The instrument is factory calibrated. Please contact RMG for re-calibration or re-ranging.

⚠ Danger

Instantly remove a damaged or unsafe instrument from service and mark it to prevent accidental usage.

Have repairs performed by the RMG only.

Note

Please verify in advance, if the correct pressure is being applied (valves/ ball valve etc. open), the right supply voltage and wiring has been chosen.

2 Taking into operation

Mounting position

- Horizontal
- Gas connection to the side

20

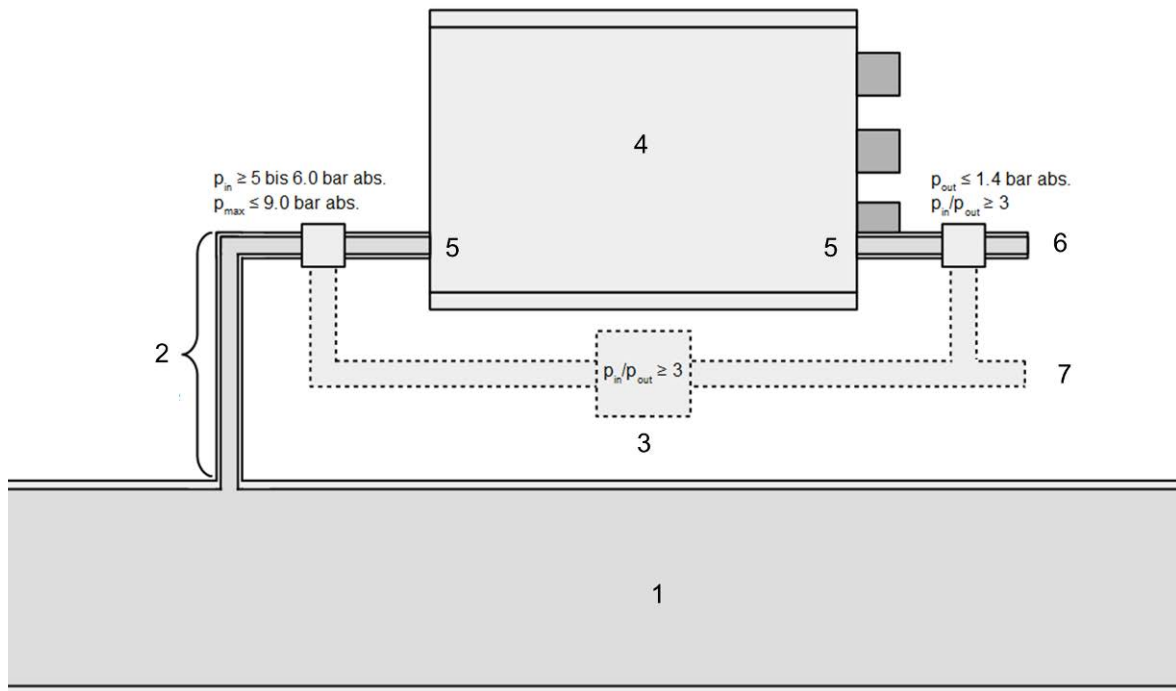

- | | |
|-----------------------------------|---|
| 1 Main pipeline | 4 Gas consumption: 0,1 l _n / measurement |
| 2 Supply line: | 5 6 mm male thread |
| - dry, neutral gases | Optional: 1/4" male thread |
| - 10 μm filtering | 6 Low-pressure section or |
| - as short as possible | 7 Direct exhaust pipe |
| - small diameter | |
| 3 Bypass: Reduction reaction time | |

Figure 7: Connection of the GQS 400-F into the gas pipeline



Danger

Make sure that the device to be installed has been calibrated for the type of gas present in the system. No observance not only could lead to possible damage due to erroneous process control value, but even hazardous situations could emerge.

Flow Direction and Outlet

The GQS 400-F has only one predefined flow direction. The instrument inlet can be directly connected to the gas line or tank and releases the media pressure free through the outlet located on the electrical connection side.

Inline Condition

Required is dry, filtered gas (with an external particle filtration down to 10 µm). The depressurized flow out is located on electrical connection side. The dew point of the gas mixture should be below 10 K of the lowest operating temperature

Note

It is NOT possible to feed the sample gas back into the inlet pressure section due to the required pressure drop.

No other measuring device (e.g. GQS 400-F, PGC9300, etc.) may be attached to the outlet (in series).

Gas Release

RMG recommends continuous purge bypass – keep outline atmosphere above *UEL (non-hazardous)*.

Therefore, split the inline and conduct it parallel to the instrument over a pressure dropper and reunite it with the outline. The inlet pressure must be five times the outlet pressure.

Best Measuring Performance

The measurement will be carried out on a small amount of sample gas at low flow rates. For low latency results install a purge bypass and avoid long gas lines.

Pollution and Abrasion

Make sure there is **no** pollution inside the sensor in- and outlet before connecting the instrument. Do **NOT** use any lubricant or sealant. Abrasion can damage or even destroy the sensor.

Mechanical Stress, Liquids and Dirt

Do **NOT** insert any item into the openings. mechanical stress, liquids and dirt may damage or destroy the sensor. Warranty excludes failures and damage caused by the customer, such as contamination, improper electrical hook-up, dropping etc.

22

Maximum Torque

To avoid mechanical damage, please **DO NOT** drive more than 6 Nm torque on instruments threads (G1/8") and 2 Nm on earth connector.

Mounting Position

The instrument has to be mounted upright in **horizontal position with electrical and process connections directing to the side** (see *Figure 8: Best mounting performance*). Otherwise the specified measurement performance cannot be guaranteed.

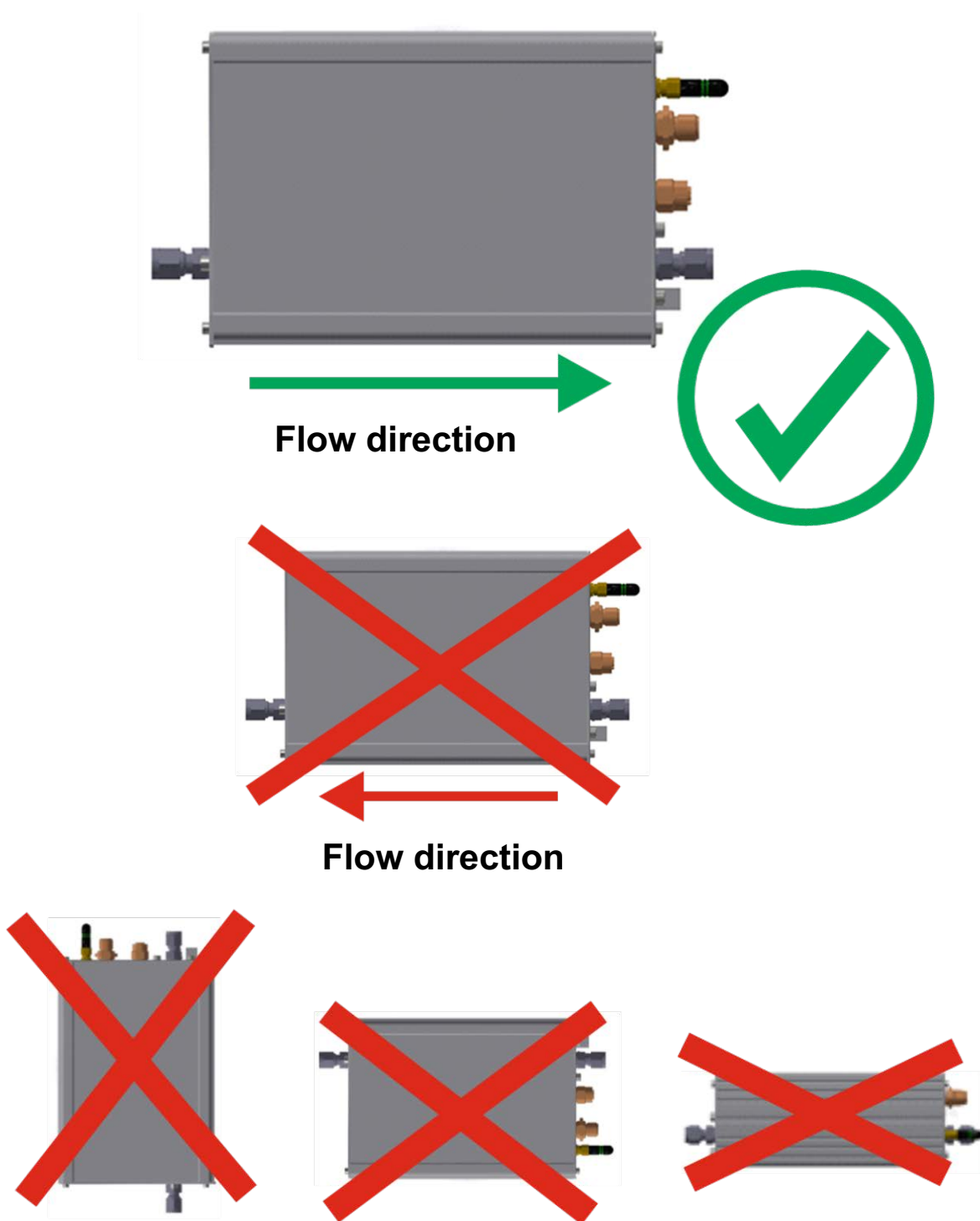

Figure 8: Best mounting performance

2.1 Electrical connection

2.1.1 Required material

- device: GQS 400-F
- power supply (+13.5 VDC \pm 5 %);
recommended: Mems MINI-PS-12-24DC/5-15DC/2-X
- supply cable with M12-A, female connector
- communication cable with M12-A, male connector
- Y-junction M12-A
- termination resistor M12-A
- Zener barrier for supply (recommended: Pepperl+Fuchs Z713)
- Zener barrier for communication (recommended: Pepperl+Fuchs Z757)

2.1.2 Optional material

- *GPIO cable with M12-B female connector*
- *Zener barrier for GPIO (recommended: Pepperl+Fuchs Z728)*

Note

The GPIO interface is intended exclusively for internal investigations.

2.1.3 Connections

There are three electrical connections on the GQS 400-F (see *Figure 9: backplate with connections*). The next *chapter 2.1.4 Mechanical interface* shows the exact pin out and pin location of the different M12 connectors. RMG uses a Modbus-RTU protocol to communicate. For more details please refer to *Appendix D: Modbus specifications*.

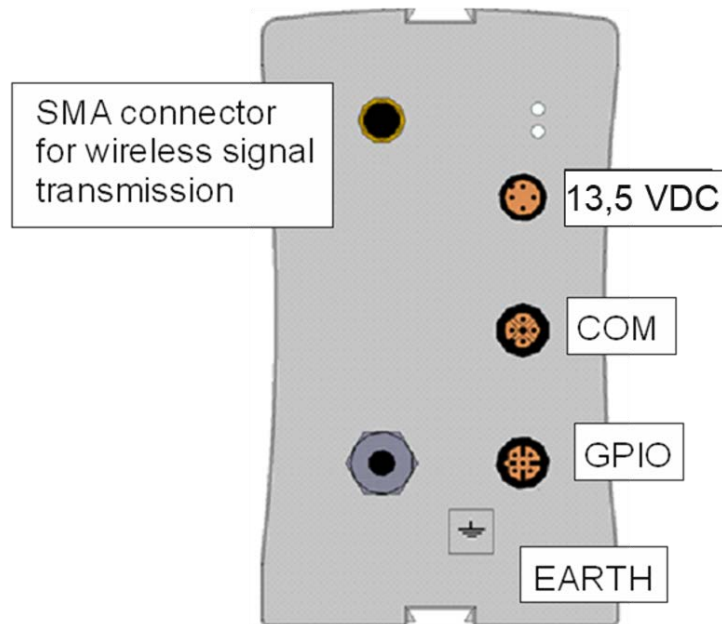

Figure 9: backplate with connections

2.1.4 Mechanical interface

2.1.4.1 Power

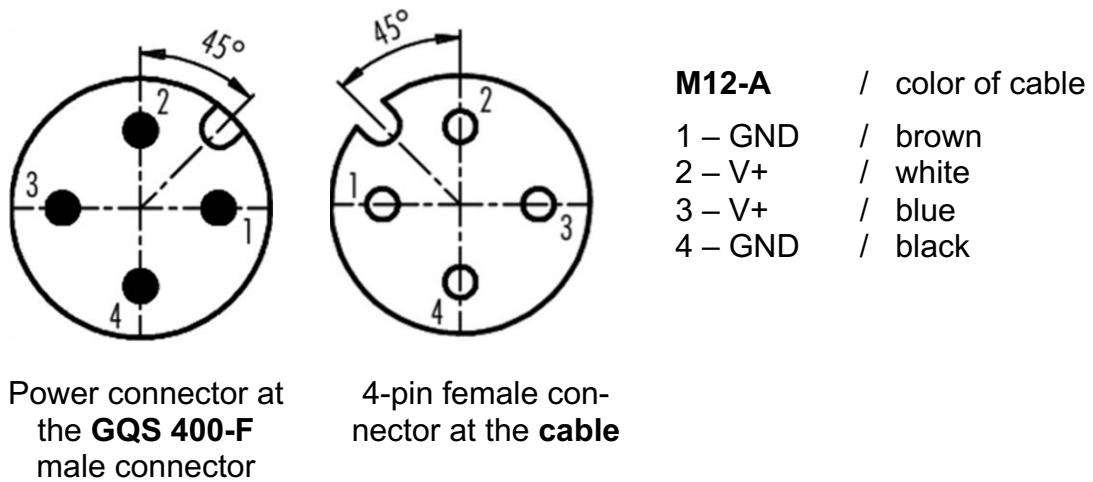
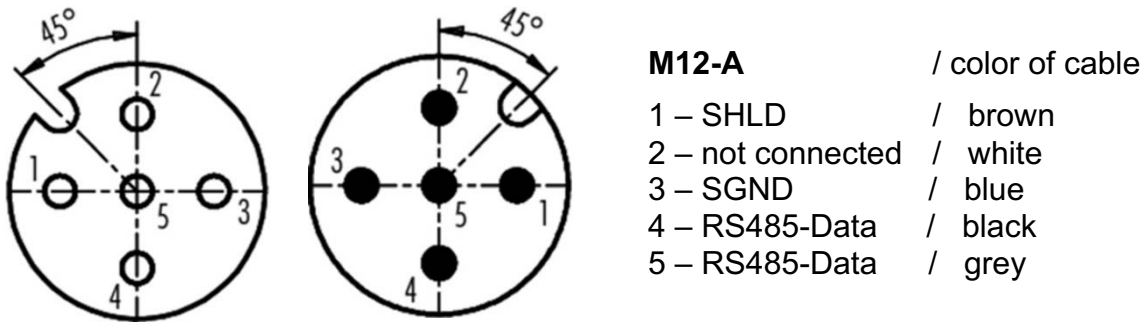

Figure 10: power connection

2.1.4.2 Communication



Female COM connector at the **GQS 400-F**

5-pin male connector at the **cable**

Figure 11: communication connection

2.1.4.3 GPIO (for internal use only)

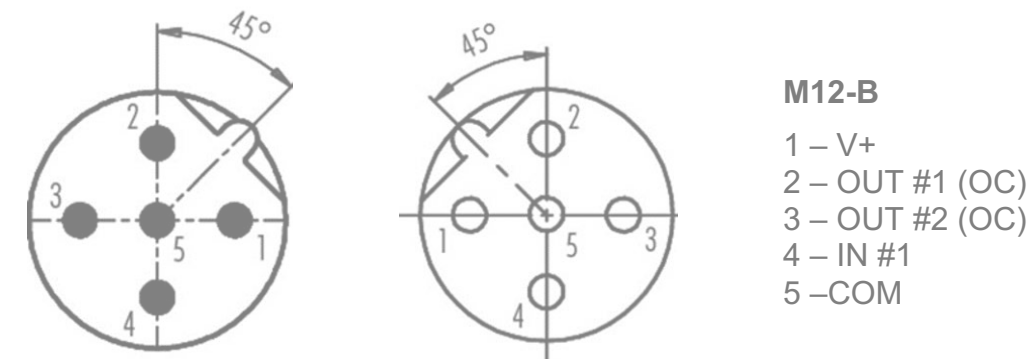

GPIO connector at the **GQS 400-F**

5-pin female connector at the **cable**

Figure 12: GPIO connection

2.1.4.4 Electrical connection diagrams

The electrical connection diagram for Zone 1 (without taking into account the GPIO interface) can be seen on the next page.

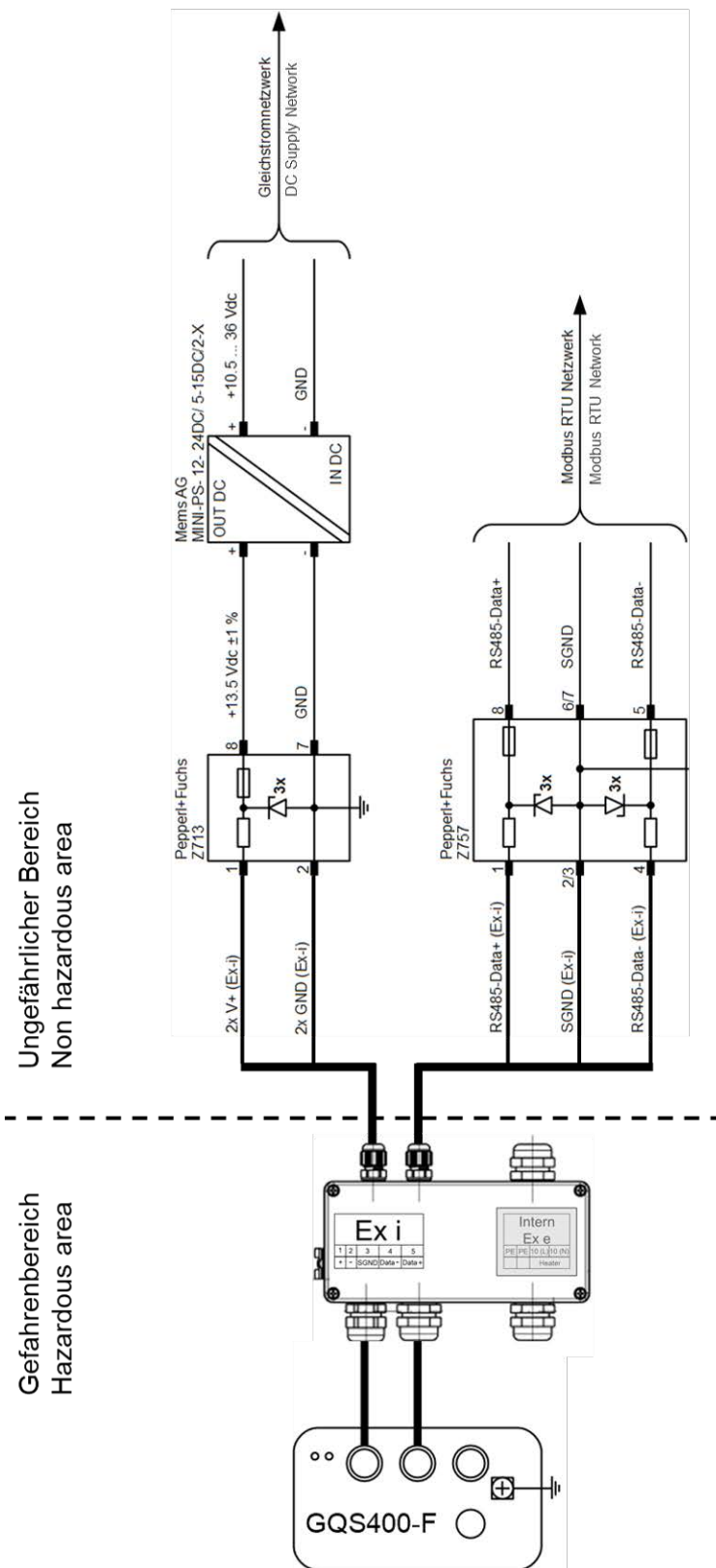

Figure 13: Electrical connection diagram GQS 400-FS for Zone 1

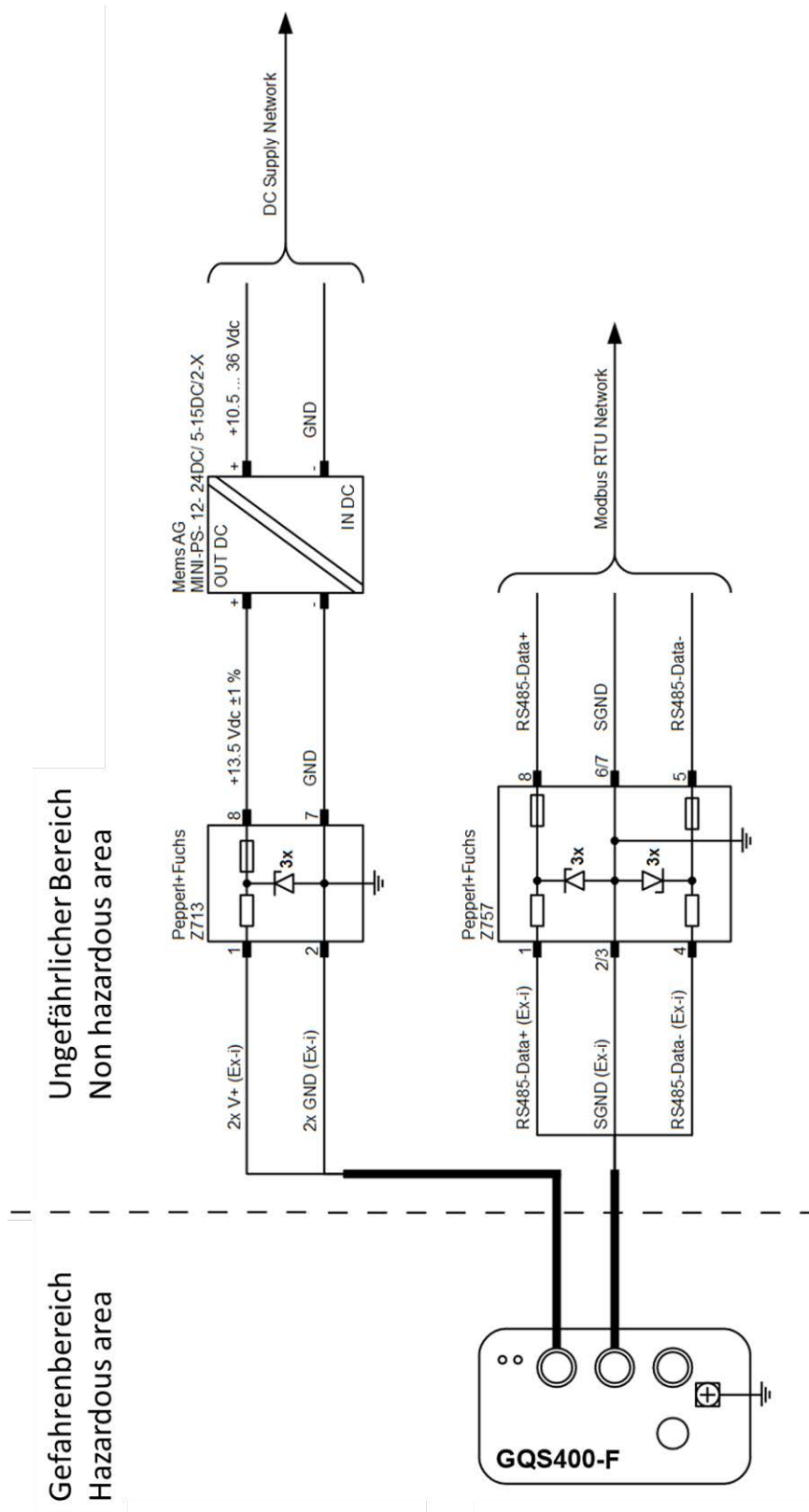

Figure 14: Electrical connection diagram GQS 400-FT for Zone 1

⚠ Danger

For installation in hazardous areas ensure that the enclosure is potentially equalized.

To increase immunity against electromagnetic interference, RMG recommends connecting the shield of the cable to earth at both ends. Attention for applications in hazardous areas, it must be ensured that potential equalization exists between the various earthing points (i.e. between the hazardous area and safe area). For more information please refer to standard EN 60079-14.

Connect the instrument only to intrinsically safe circuits (Ex ia).

Cover flying leads with fine wires by an end splice (cable preparation).

_____ 29 _____

⚠ Danger

Ensure that supplied voltage adheres to the specified electrical characteristics and never exceeds the maximum limit (see *chapter 5.1 Electrical Parameter*).

⚠ Danger

Do not shorten, extend or replace the provided cable without consultation of an authorized RMG service engineer.

⚠ Caution

Electrostatic discharge can damage equipment, impair electrical circuitry and can result in complete or intermittent failures. Always place the protective caps on the connector when they are not used and do not touch the connector pins.

3 Operation

The GQS 400-F has no external switches. RMG recommends turning on the power supply first and then connect the top M12 connector at the instrument. The upper LED indicates communication status, the lower LED the status of the instrument.

30

	LED	Colour	Value	State
	1	Yellow	Communication	Flashing during frame reception or sending
		Red	Error	Blinking at 2Hz: internal fault (communication or configuration error)
		Green	Device status	Switched ON: Device powered
	2	Yellow	Measurement	Switched ON: Device busy
		Red	Error	Blinking at 2Hz: Measurement failed or boundaries out of range
		Green	Device status	Switched ON: Device ready for measurement

Figure 15: LED status

Operation Mode: Interval

The instrument repeats the measurement in a user defined time interval (min. 60 s, max. 24 h). The required parameter sample time (time interval in seconds) and purge time (purging of the sensor in seconds) can be defined over the Modbus.

Operation Mode: On request

The instrument performs a single measurement cycle as soon as a measurement command is received via the Modbus.

For more details about the Modbus protocol please refer to *Appendix D: Modbus specifications*.

Bootloader mode

In case there is no firmware installed, the instrument will stay in bootloader mode and waits for the download of the firmware over Modbus. The bootloader can also be triggered over the Modbus to update the installed firmware.

For more details about the bootloader please refer to *Appendix D: Modbus specifications*.

4 Troubleshooting

Failure	Possible Cause	Procedure
Instrument does not boot	No / incorrect voltage supply	Adjust the voltage supply to comply with the operating instructions *)
	Cable break / connection loss	Check connections and cable
Output signal diverges from expected value	Instrument is not calibrated for used gas mixture.	Check documentation
	Residual gas inside the instrument or its inlet pipe	Make sure that the pipe is purged completely with new gas mixture.
	Instrument is not mounted in horizontal position.	Put installation out of operation and mount instrument as described in <i>chapter 2 Taking into operation</i> .
	Micro-thermal sensor is damaged.	Contact the manufacturer and replace the instrument

* Make sure that after the setting of the unit is working properly. In case of a remaining error send back the instrument for reparation (and replace the unit).

In case of unjustified reclamation, we may charge a reclamation handling expense.

5 Technical data

5.1 Electrical Parameter

Note
<p>Before connecting the voltage supply, ensure that all gas lines to the measuring element and the measuring element itself have been flushed.</p>

33

Supply voltage: +13.5 VDC ± 5 %
 Power consumption: < 1.0 W

⚠ Danger
<p>For calculation of the intrinsic safe RS485 output circuit the internal capacitance of $C_i = 1.1 \mu\text{F}$ and the internal inductance of $L_i = 52 \mu\text{H}$ must be regarded.</p>

5.2 Pressure Parameter

Inlet pressure:	min. 4.5 bar absolute max. 6.0 bar absolute Setup on the mounting plate: min. 5 bar absolute max. 18 bar absolute
Permissible overload:	9.0 bar absolute Setup on the mounting plate: max. 18 bar absolute (temporary limited to 18 bar)
Outlet pressure:	max. 1.4 bar absolute

5.3 Operating Temperature

Adhere to the permissible ambient and medium temperatures which are valid for this area on the basis of the specified temperature classes. The maximum permissible temperature range is specified on the type plate of the GQS 400-F. Operation of the device is only permitted within these specified ranges.

Ambient air temperature range:	-10 °C to +55 °C
Maximum surface temperature:	< 135 °C

Danger

Protect the instrument from heat sources (e.g. pipes or tanks).

5.4 Measured media

Dry, neutral gas (filtered 10 µm)

The GQS 400-F can measure "normal" natural gas of the gas family G260 in the wider range, in the form of H-gas or L-gas, as well as biogas or other (natural) gas compositions. However, the GQS 400-F should be calibrated to the respective gas type.

Please consult RMG if you are unsure whether your gas or parts of your gas are aggressive.

Appendix

Appendix A: Name plates

Configuration plate of the QQS 400-F

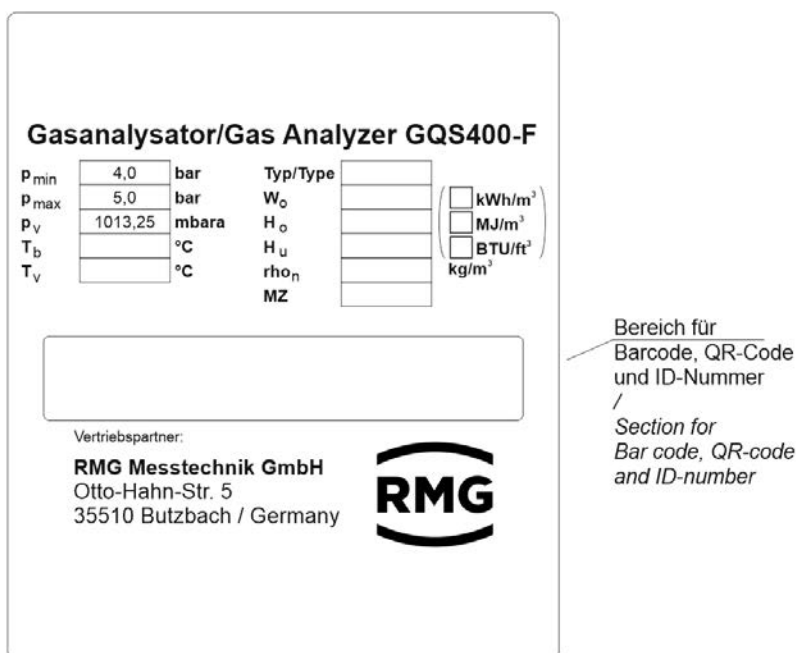

Figure 16: Configuration plate of QQS 400-F

Name plate of the QQS 400-F from Fa. Mems

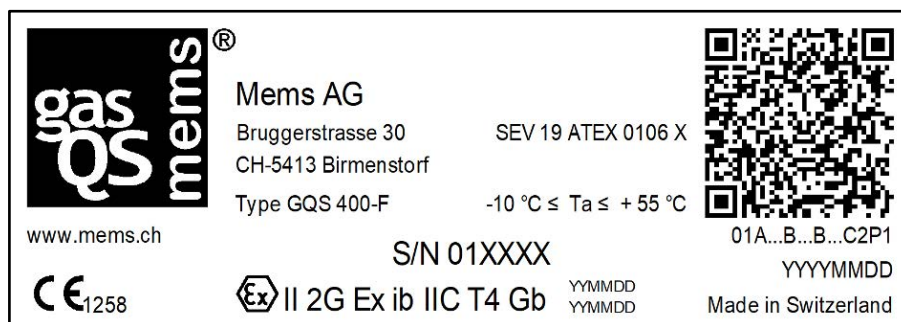

Figure 17: Name plate of QQS 400-F; Company Mems AG

The next figure shows the mounting positions of the nameplates on the device

36



Figure 18: Name plate on the side of the GQS 400-F

GQS 400-F on the mounting plate

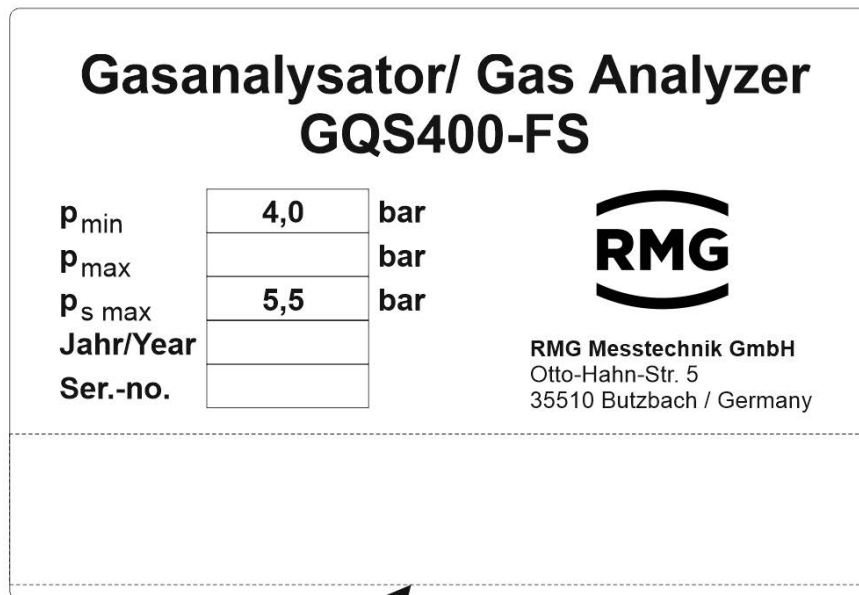

_____ 37 _____



 Bereich für Barcode / section for Bar code

Figure 19: Name plate of GQS 400-FS

Appendix B: Connection GQS 400-F to an ERZ2000-NG

For investigations, the GQS 400-F can be connected to an ERZ2000-NG. This allows the data of the GQS 400-F to be recorded.

38

Note

If (additionally) a gas quality measuring instrument (e.g. a PGC 9300) is connected to the ERZ2000-NG, which values are used for calculations (of further gas parameters) of the ERZ2000-NG then the frequency of the recording is no longer determined by the trigger of the GQS 400-F, but by the frequency trigger of the gas quality measuring instrument (e.g. the PGC 9300 instrument).

The data of the GQS 400-F is then recorded, but always when the gas quality measuring instrument (e.g. the PGC 9300) transmits new data.

The next figure shows the connection of the GQS 400-F to the ERZ2000-NG. The GQS 400-F is generally connected to the COM 6 / COM 7 interface on the rear of the ERZ2000-NG via an isolating switching amplifier.

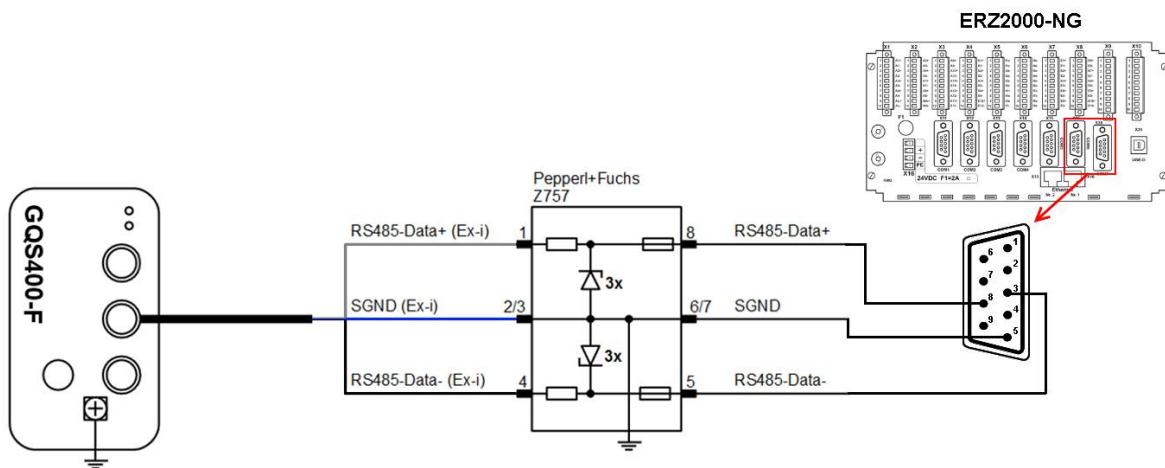

Figure 20: Connecting the GQS 400-F to an ERZ2000-NG

Connections:

	GQS 400-F	Z757 // EX-i	Z757 / non EX	ERZ200-NG / Com6/7
SGND	Pin 3	Pin 2/3	Pin 6/7	Pin 5
RS485 Data-	Pin 4	Pin 4	Pin 5	Pin 3
RS485 Data+	Pin 5	Pin 5	Pin 8	Pin 8

The following parameterization must be set out in the menus of the ERZ2000-NG:

Note

Please refer to the ERZ2000-NG manual, which can be found on our homepage, to find how to configure the ERZ2000-NG.

www.rmq.com

IL Modbus Master GC1

Access Line	Designation	Value	Unit	Variable
E *	1	Sup.calorific val.	11.064	kWh/m ³ exp1Ho
E *	2	Stand.density	0.7175	kg/m ³ exp1Rn
E *	3	Carbon dioxide	0	mole% exp1CO2
E *	4	Hydrogen	0	mole% exp1H2
E *	5	Nitrogen	0	mole% exp1N2
E *	6	Methane	100	mole% exp1Meth
E *	7	Ethane	0	mole% exp1Eth
E *	8	Propane	0	mole% exp1Prop
E *	9	N-butane	0	mole% exp1NBut
E *	10	I-butane	0	mole% exp1IBut
E *	11	N-pentane	0	mole% exp1NPen
E *	12	I-pentane	0	mole% exp1IPen
E *	13	Neo-pentane	0	mole% exp1Neop
E *	14	Hexane/C6+	0	mole% exp1Hexa
E *	15	Heptane/C7+	0	mole% exp1Hept
E *	16	Octane/C8+	0	mole% exp1Oct
E *	17	Nonane/C9+	0	mole% exp1Non
E *	18	Decane/C10+	0	mole% exp1Dec
E *	19	Hydrogen sulphide	0	mole% exp1H2S
E *	20	Water	0	mole% exp1H2O
E *	21	Helium	0	mole% exp1He
E *	22	Oxygen	0	mole% exp1O2
E *	23	Carbon monoxide	0	mole% exp1CO
E *	24	Ethene	0	mole% exp1Eten
E *	25	Propene	0	mole% exp1Ppen
E *	26	Argon	0	mole% exp1Arg
E *	27	Status	1	exp1Stat
B	28	Diagnosis 1	0	exp1Diag1
B	29	Diagnosis 2	0	exp1Diag2
D	30	Time stamp	09-01-2019 10:06:10	mb1_stamp
D	31	Analyze counter	11069	mb1AnaCnt
D	32	Communication	running	mb1_ok
D	33	Data timeout	10 s	mb1_datato
D	34	Sum components	100,000	mole% mb1KmpSum
D	35	Exception code	0	mb1ExcCod
D	36	Exception counter	0	mb1ExcCnt

Figure 21: Menu IL Modbus Master GC1 (part 1)

Please go to the menu **Communication** and there to the submenu **IL Modbus Master GC1**. With the calibration switch open, the following settings must be made there:

Coordinates IL01-IL26

Enter dummy values for a volume fraction of a realistic gas composition. The total sum of the individual volumes must be 100 %.

Coordinate IL27

The status must be 1.

Comment:

1 means measured values OK

0 means fault or test values

The COM 6 / COM 7 interface of the ERZ2000-NG is "usually" intended for the custody transfer of the gas quality from a gas analyzer (e.g. the PGC 9300). The ERZ2000-NG checks the read data for plausibility.

If "unreasonable" values were entered, the ERZ2000-NG generates warning or alarm messages.

E *	50	Operating mode	Modbus-serial C6		mb1_ifac
E *	51	IP-Address	192.168.20.143		mb1_ipAdr
E *	52	Modbus address	1		mb1_Adr
E *	53	ModbusIP timeout	2000	ms	mb1timo
E *	54	Slave accepts gaps	No		mb1_loecher
E *	55	Byteorder 16Bit Int	21		mb1_bo_u
E *	56	Byteorder 32Bit Int	4321		mb1_bo_U
E *	57	Byteorder float	4321		mb1_bo_F
E *	58	Byteorder double	21436587		mb1_bo_D
E *	59	Read function code	4		mb1_fc
A *	70	actual selected	univ.Modb.Master 1		selUmbm
A *	71	Position contact	OFF		ktkUmbm
E *	72	Selection mode	Always Master 1		modUmbm
E *	73	selected contact	OFF		kzoUmbm
B	80	measured value 1	U32778		exp1Diag1
B	81	measured value 2	U28672		exp1Diag2
B	82	measured value 3	F28674		exp1Diag3
B	83	measured value 4	F28676		exp1Diag4
B	84	measured value 5	F28678		exp1Diag5
B	85	measured value 6	F28680		exp1Diag6
B	86	measured value 7	F28682		exp1Diag7
B	87	measured value 8	F28684		exp1Diag8
B	88	measured value 9	F28686		exp1Diag9
B	89	measured value 10	u4096		exp1Diag10
B	98	used button	MEMS		exp1btn

Figure 22: Menu IL Modbus Master GC1 (part 2)

Coordinates IL50-IL59

Please apply the settings as shown in the illustration.

Comment:

Coordinate IL51 and **coordinate IL53** are irrelevant, since there is a serial cable connection via COM 6 / COM 7. The **coordinate IL72** must be set to "always master 1" and the **coordinate IL 73** to "OFF".

Coordinates IL80-IL89

The Modbus addresses of the GQS 400-F are entered in here. Further information can be found in the Modbus specification of the GQS 400-F.

Coordinate IL 89

The letter "u" must be written in small letters. Small letters indicate 16-bit values, large letters 32-bit values.

Coordinate IL 98

This is a freely definable name, e.g. the identification of the GQS 400-F device.

For further recordings, settings in the **menu O** in the **submenus OF** to **OM** must be made:

OF Extra analog value 1

Access	Line	Designation	Value	Unit	Variable
D	1	Measured value	295,950	K	ana1
D	2	Input value -> IL82	F28674		ana1Qll
B	3	Operating mode	Meas.=int.value ▾		ana1Mod
B	4	Unit	K		ana1Dim
B	5	Default	300,000	K	ana1Vg
B	6	Lower warning limit	-2,000	K	ana1WGwu
B	7	Upper warning limit	500,000	K	ana1WGwo
B	11	Coefficient 0	0		ana1K0
B	12	Coefficient 1	0		ana1K1
B	13	Coefficient 2	0		ana1K2
B	14	Coefficient 3	0		ana1K3
B	16	1st source	aus		ana1Inp
B	18	2nd source	aus		ana1Inp2
B	19	Internal choice = IL82 Edit			ana1Ausw
D	21	Base value	295,950	K	ana1Org
D	22	Mean for DSfG	295,850	K	ana1Emiw
D	25	2nd input value	(...)		ana1Qll2
D	27	Current status	ok		ana1CEstt
D	28	DSfG status	ok		ana1Estt
G *	30	Format	%.3f		ana1Frm
D	37	Ongoing mean	295,857	K	ana1CEmiw
B	53	Symbol	GQS Temp. gas		ana1Symbol

Figure 23: Menu IF Extra analog value 1

Coordinate OF03

The operating mode is set to "Meas.=int value".

Coordinates OF4-OF7

Input of unit, default value (replacement value in case of error) and warning limits.

Coordinates OF11-OF18

Please enter the settings as shown in the figure.

Coordinate OF19

Here the complete coordinate must be assigned in the menu **IL Modbus Master GC1**.

Coordinate OF30

Here you set the display, i.e. the number of decimal digits.

Coordinate OF53

The name of the measured variable is entered here.

OU Free programmable archive

Access Line	Designation	Value	Unit	Variable
B 1	Record cycle	gas quality		fpagZyk
B 10	Assign.Channel 1 = OF01	Edit	%	fpagk1
B 11	Assign.Channel 2 = OG01	Edit	%	fpagk2
B 12	Assign.Channel 3 = OH01	Edit	%	fpagk3
B 13	Assign.Channel 4 = OI01	Edit	%	fpagk4
B 14	Assign.Channel 5 = OJ01	Edit	%	fpagk5
B 15	Assign.Channel 6 = OK01	Edit	%	fpagk6
B 16	Assign.Channel 7 = OL01	Edit	%	fpagk7
B 17	Assign.Channel 8 = IL31	Edit		fpagk8
B 18	Assign.Channel 9 = OM01	Edit	%	fpagk9
B 19	Assign.Channel 10 = OC01	Edit		fpagk10
B 20	Assign.Channel 11 = OC01	Edit		fpagk11
B 21	Assign.Channel 12 = OC01	Edit		fpagk12
B 22	Assign.Channel 13 = OC01	Edit		fpagk13
B 23	Assign.Channel 14 = OC01	Edit		fpagk14
B 24	Assign.Channel 15 = OC01	Edit		fpagk15
B 25	Assign.Channel 16 = OC01	Edit		fpagk16
B 26	Assign.Channel 17 = OC01	Edit		fpagk17
B 27	Assign.Channel 18 = OC01	Edit		fpagk18
B 28	Assign.Channel 19 = OC01	Edit		fpagk19
B 29	Assign.Channel 20 = OC01	Edit		fpagk20
D 30	GQ trigger	00000000	hex	gbhTrigger
D 31	GQ trig. pattern	00000000	hex	gbhTrgPatt

Figure 24: Menu OU Free programmable archive

Finally, select the values to be archived in the **menu OU Freely programmable archive**. As above, the coordinates of the **menu OF** to be archived must be entered completely (i.e. with number).

Coordinate OU01

The recording cycle is selected here. With the selection "Gas quality" the data are then archived if the read-in data change their value (i.e. in the cycle of the GQS 400-F device).

Appendix C: Certificates

Certificate of Conformity (Konformitätsbescheinigung)

Note

This is the example of a Certificate of Conformity, which depends on the inspection batch. Therefore, it is not static.

EU-Type Examination Certificate (Baumusterprüfbescheinigung)



Electrosuisse
Product Testing



- (1) **Konformitätsbescheinigung**
Konformität mit dem Baumuster auf der Grundlage einer Produktprüfung
Anhang V
- (2) Geräte und Schutzsysteme zur bestimmungsgemässen Verwendung
in explosionsgefährdeten Bereichen - **Richtlinie 2014/34/EU**
- (3) Prüfbescheinigungsnummer: **SEV 18 ATEX 5157**
- (4) Hersteller: Mems AG
- (5) Anschrift: Bruggerstrasse 30, 5413 Birmenstorf AG, SCHWEIZ
- (6) Produkt: Gasqualitätsmessgerät
- (7) Typ / Modell: gasQS flonic
- (8) Serie- / Losnummer: 180823
- (9) Stückzahl: 4
- (10) Alle oben aufgeführten Geräte wurden unter der Verantwortung von Eurofins, benannte Stelle Nr. 1258, einzeln geprüft und konform befunden mit den zutreffenden Anforderungen der Richtlinie 2014/34/EU und der korrespondierenden EU-Baumusterprüfbescheinigung SEV 18 ATEX 0111 X. Die Ergebnisse der Prüfung sind im vertraulichen Prüfbericht 18-Ex-0157.02 festgehalten.
- (11) Gemäss Artikel 16 (3) der Richtlinie 2014/34/EU ist hinter der CE-Kennzeichnung die Kennnummer 1258 von Eurofins als der benannten Stelle angegeben, die in der Fertigungsphase verantwortlich tätig war.

Eurofins Electrosuisse Product Testing AG
Notified Body ATEX

Martin Plüss
Product Certification

www.eurofins.ch

Fehraltorf, 27.08.2018

Ausgabe: 000

Seite 1 von 1





(1) EU-Type Examination Certificate

- (2) Equipment or protective system intended for use in potentially explosive atmospheres - **Directive 2014/34/EU**
- (3) Certificate number: **SEV 19 ATEX 0106 X**
- (4) Product: Gas quality measurement device
Type GQS 400-F
- (5) Manufacturer: Mems AG
- (6) Address: Bruggerstrasse 30, 5413 Birmenstorf AG, SWITZERLAND
- (7) The equipment and any acceptable variation thereto is specified in the schedule to this certificate and the documents therein referred to.
- (8) Eurofins, notified body No. 1258, in accordance with article 17 of Directive 2014/34/EU of the European parliament and of the council, dated 26 February 2014, certifies that this product has been found to comply with the essential health and safety requirements relating to the design and construction of products intended for use in potentially explosive atmospheres given in Annex II to the Directive.
The examination and test results are recorded in confidential report no 17-Ex-0114.X12
- (9) Compliance with the essential health and safety requirements has been assured by compliance with:
EN 60079-0:12 + A11:13 EN 60079-11:12
Except in respect of those requirements listed at item 18 of the schedule.
- (10) If the sign «X» is placed after the certificate number, it indicates that the product is subjected to special conditions for safe use specified in the schedule to this certificate.
- (11) This EU type examination certificate relates only to design and construction of the specified product. Further requirements of this directive apply to the manufacturing process and supply of this product. These are not covered by this certificate.
- (12) The marking of the product shall include the following:

 **II 2G Ex ib IIC T4 Gb**

Eurofins Electrosuisse Product Testing AG
Notified Body ATEX

Martin Plüss
Product Certification



www.eurofins.ch

Fehraltorf, 2019-01-23

Issue: 000

page 1 of 3





(13)

Appendix

(14)

EU-Type Examination Certificate no. SEV 19 ATEX 0106

(15) **Description of product**

The QQS 400-F is a micro-electromechanical gas quality measurement device. Based on its CMOS chip micro-thermal flow sensor in combination with a sonic nozzle and two on/off valves, thermal conductivity, heat capacity and relative density of natural gas are measured. From these parameters, calorific value or Wobbe index are correlated.

Compared to process gas chromatographs, the typical analytical tool to determine gas parameters, this standalone device needs no carrier gas, is robust, compact and inexpensive. It also provides a control output for automatic calibration in the field.

The device is connected via intrinsic safe associated apparatus to supply power, RS485 or CAN interface and GPIO interface.

Classification of installation and use:	Stationary
Ingress protection:	IP20
Rated ambient temperature range (°C):	-10 °C ... +55 °C

Rating:

Supply circuit	U_i = 15.75 V
	I_i = 0.723 A
	P_i = 2.84 W
	C_i = 0.188 μ F
	L_i = 0.024 mH

GPIO circuit	U_i = 28.0 V
	I_i = 0.1 A
	P_i = 0.7 W
	C_i = 0.003 μ F
	L_i = 0.01 mH

RS485 respective CAN circuit	Input circuit:		Output circuit:	
	U_i = 7.5 V		U_o = 4.1 V	
	I_i = 0.75 A		I_o = 0.091 A	
	P_i = 1.4 W		P_o = 0.094 W	
	C_i = 1.1 μ F		C_o = 7.9 μ F	
	L_i = 52 μ H		L_o = 0.2 mH	
		C_i = 1.1 μ F (max. internal capacity)		
		L_i = 52 μ H (max. internal inductance)		





- (16) **Report number** 17-Ex-0114.X12
- (17) **Specific conditions of use**
- For calculation of the intrinsic safe RS485/CAN output circuit the internal capacitance of $C_i = 1.1 \mu\text{F}$ and the internal inductance of $L_i = 52 \mu\text{H}$ must be regarded.
- (18) **Essential health and safety requirements**
- In addition to the essential health and safety requirements (EHSRs) covered by the standards listed at item 9, the following are considered relevant to this product, and conformity is demonstrated in the report:
- | Clause | Subject |
|--------|---------|
| None | |
- (19) **Drawings and Documents**
- See test report "Manufacturer's Documents"



Appendix D: Modbus specifications

Version 20

51

Contact

Subject to technical modifications

For further information

If you would like to learn more about the products and solutions from RMG, please visit our website:

www.rmg.com

or your local support office
or contact your local sales representative

RMG Messtechnik GmbH

Otto-Hahn-Straße 5
35510 Butzbach, Germany
Phone: +49 (0) 6033 897 – 0
Fax: +49 (0) 6033 897 – 130
Email: service@rmg.com

