

TECHNICAL MANUAL

Type ERZ 9000 T

Status: 09/98
Subjekt to change

CONTENTS

1	Introduction	3
2	Front Panel	4
3	Block Diagrams	5
3.1	Overview	5
3.2	View without front panel	6
3.3	Plug-in assembly - rack mounting unit	7
3.4	Plug-in assembly - wall mounting unit	8
4	Function Charts	9
4.1	ERZ 9002 T Density Corrector	9
4.2	ERZ 9002/4 T Density Corrector	10
4.3	ERZ 9002 TM Mass Corrector	11
4.4	ERZ 9102 T Superior Calorific Value Corrector	12
4.5	ERZ 9102/4 T Superior Calorific Value Corrector	13
4.6	ERZ 9004 T Volume Corrector	14
4.7	ERZ 9104 T Superior Calorific Value Corrector	15
5	Construction	16
5.1	Technical data	16
5.2	Mode of operation	19
6	General Wiring Instructions	23
7	Pin Assignment Diagrams	24
7.1	Rear panel of the rack-mounting unit	24
7.2	Pin assignments for the inputs of the rack-mounting unit	25
7.3	Pin assignments for the outputs of the rack-mounting unit	26
7.4	Pin assignments for the inputs of the wall-mounting unit	27
7.5	Pin assignments for the outputs of the wall-mounting unit	28
8	Wiring Examples	29
8.1	Input for pressure transmitter	29
8.2	Input for temperature transmitter	29
8.3	Input for density transducer, Type DG 08	30
8.4	Input for Standard density transducer, Type NDG 08	30
8.5	Input for Velocity of Sound transducer, Type VOS 07	31
8.6	Input for r_n / Hs correction	31
8.7	Input for volume measurement	32
8.8	Analog output	33
8.9	Relay output	33
8.10	Optocoupler output	33
9	DSfG Extension	34

1 Introduction

The display field:

An alphanumeric 2-line display with 20 characters per line enables data and measured values to be indicated together with their short designations and units. The display field consists of a fluorescent display in blue and is easily readable even from a distance.

The system:

A complete Flow Computer System has been developed taking the size of a Eurocard as a basis and using the most advanced SMD technology with large-scale integrated components. A fully assembled printed circuit board incorporates all inputs required for a complex corrector. The range extends from simple volume correctors through density correctors to superior calorific value correctors. The type of the individual device essentially depends on the software used. Therefore, all conceivable special versions, such as density computers or superior calorific value computers, are possible. Thanks to large-scale integrated components, fewer parts are required and this also contributes to making the device reliable.

The "turbo" model incorporates a second CPU card to increase the computing power. This "turbo" CPU mainly performs arithmetic operations, whereas the standard CPU continues to carry out all measuring tasks. An interface module can be plugged onto the back of this "turbo" CPU in order to provide the device with another four data interfaces. One of these interfaces is dedicated to the DSfG application, for example.

The types of devices:

Type of device	Description	Aktive columns of the system of coordinates												
		A	B	C	D	E	F	G	H	I	J	K	L	M-ZB
ERZ 9002 T	Density corrector			X	X		X	X	X	X	X	X		X
ERZ 9002/4 T	Density corrector with calculation of a reference volume correction factor via pressure and temperature in the background	X		X	X	X	X	X	X	X	X	X	X	X
ERZ 9002 TM	Mass computer						X	X			X	X		X
ERZ 9102 T	Superior calorific value corrector (density)		X	X	X		X	X	X	X	X	X		X
ERZ 9102/4 T	Superior calorific value corrector (density) with calculation of a reference volume correction factor via pressure and temperature in the background	X	X	X	X	X	X	X	X	X	X	X	X	X
ERZ 9004 T	Volume corrector with calculation of GERG 88 S via measured values for H_s , ρ_n and CO_2	X	X	X		X	X			X	X	X	X	X
ERZ 9104 T	Superior calorific value corrector (state) with calculation of GERG 88 S via measured values for H_s , ρ_n and CO_2	X	X	X		X	X			X	X	X	X	X

2 Front Panel

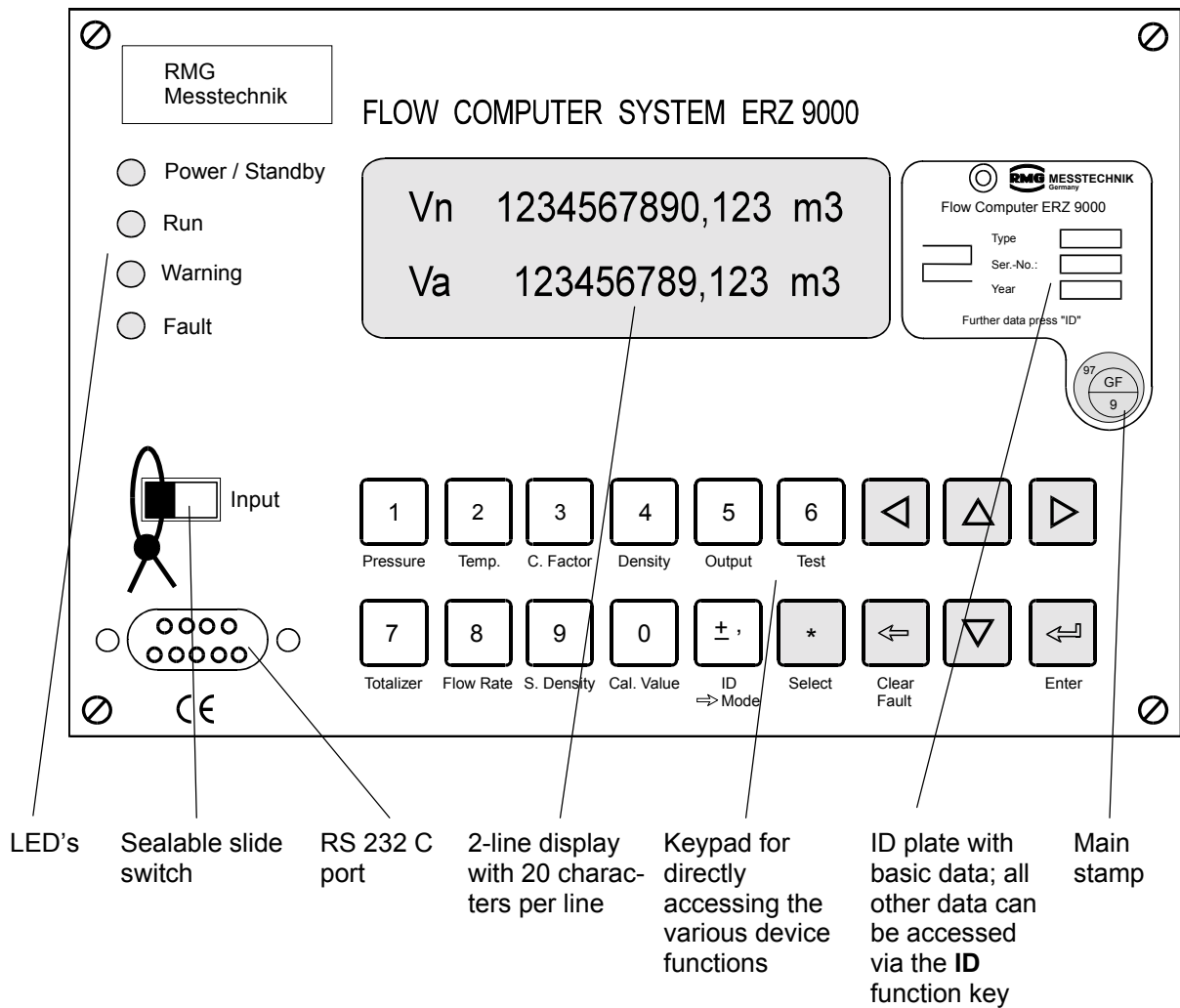

3 Block Diagrams

3.1 Overview

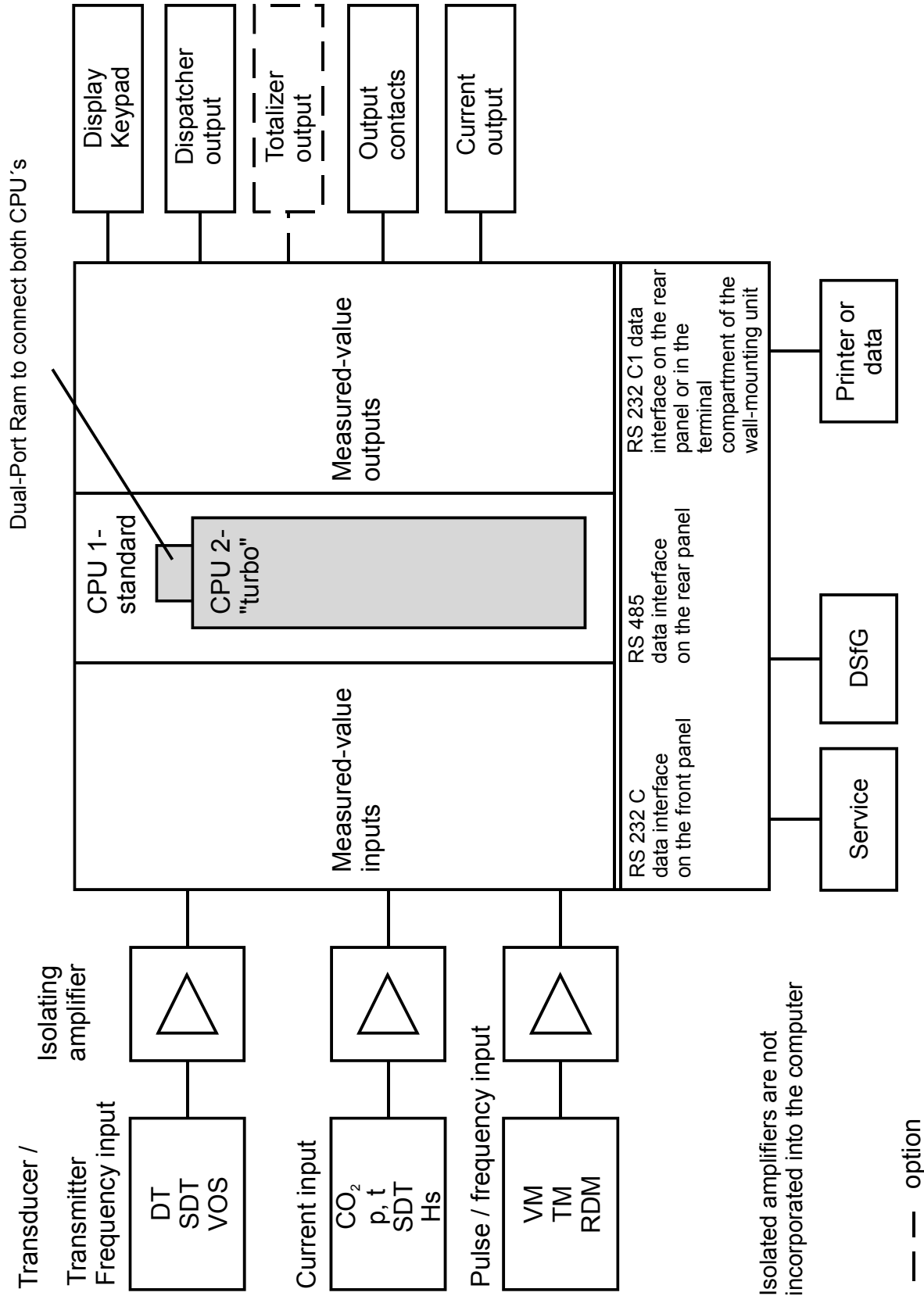

3.2 View without front panel

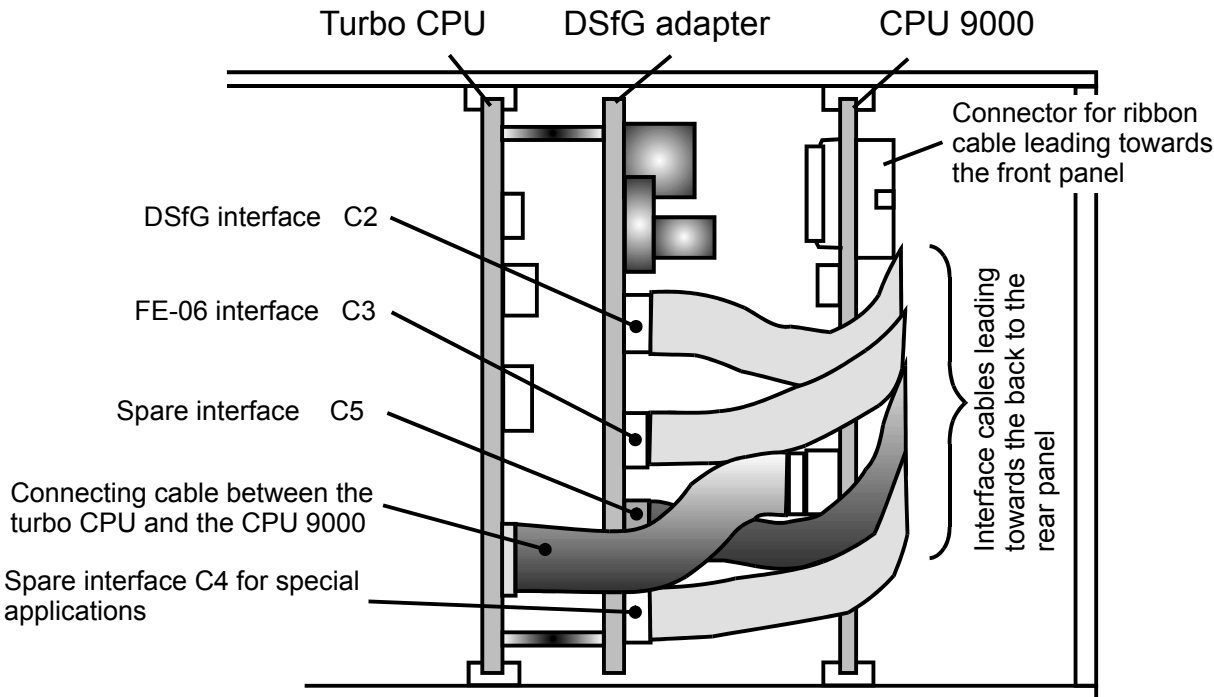

3.3 Plug-in assembly of the rack-mounting unit

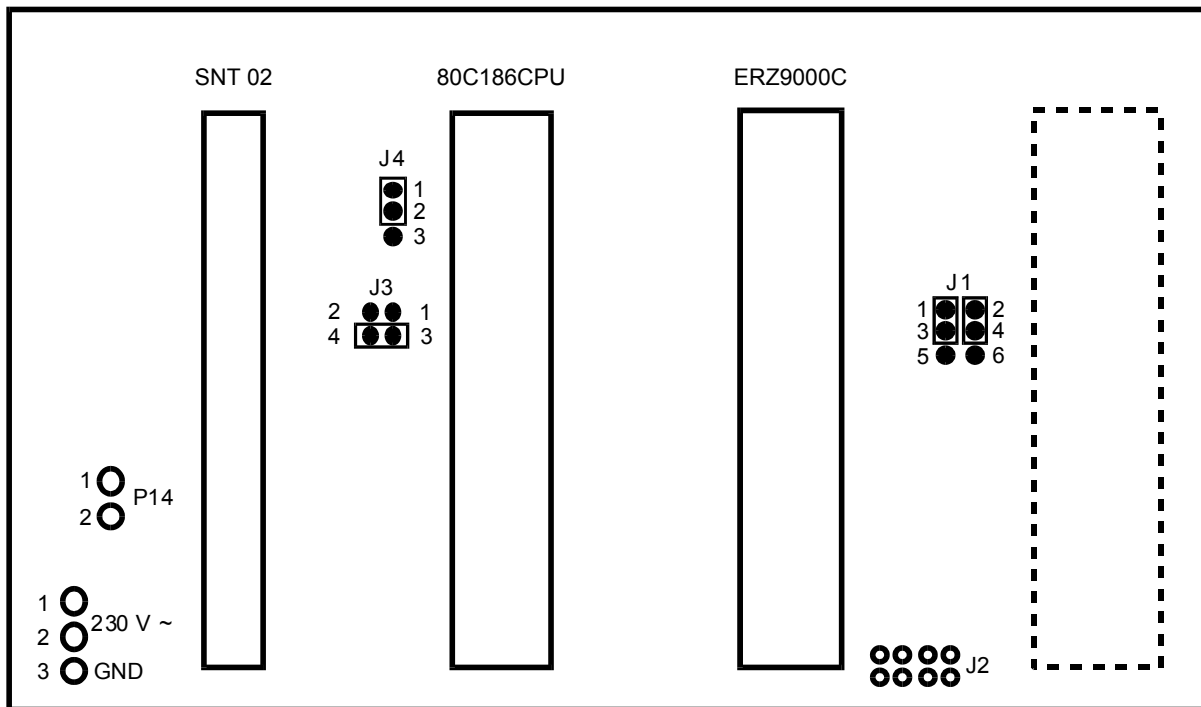

Explosion-proof isolation of pulse inputs - Jumper J1

Setting is to be made via the jumper J1. The following settings are possible:

- 1 - 3: Explosion-proof isolation of the measuring channel is provided outside the ERZ 9000 system.
- 2 - 4: Explosion-proof isolation of the reference channel is provided outside the ERZ 9000 system.
- 3 - 5: Explosion-proof isolation of the measuring channel is provided inside the ERZ 9000 system.
- 4 - 6: Explosion-proof isolation of the reference channel is provided inside the ERZ 9000 system.

Note: For the ERZ 9000 Turbo, explosion-proof isolation is generally provided outside the ERZ system!

Input for H/L gas switching - Jumper J3

The following settings are possible:

- 1 - 2: Reset - watchdog (for NL version)
- 3 - 4: H/L gas switching or route (standard)

Reset setting - Jumper J4

The following settings are possible:

- 1 - 2: With watchdog reset (standard)
- 2 - 3: With power-on reset only

External standby power supply - P14

In order to operate the ERZ 9000 system with an external standby power supply, it is necessary to set a jumper between the soldering points P14-1 and P14-2.

3.4 Plug-in assembly of the wall-mounting unit

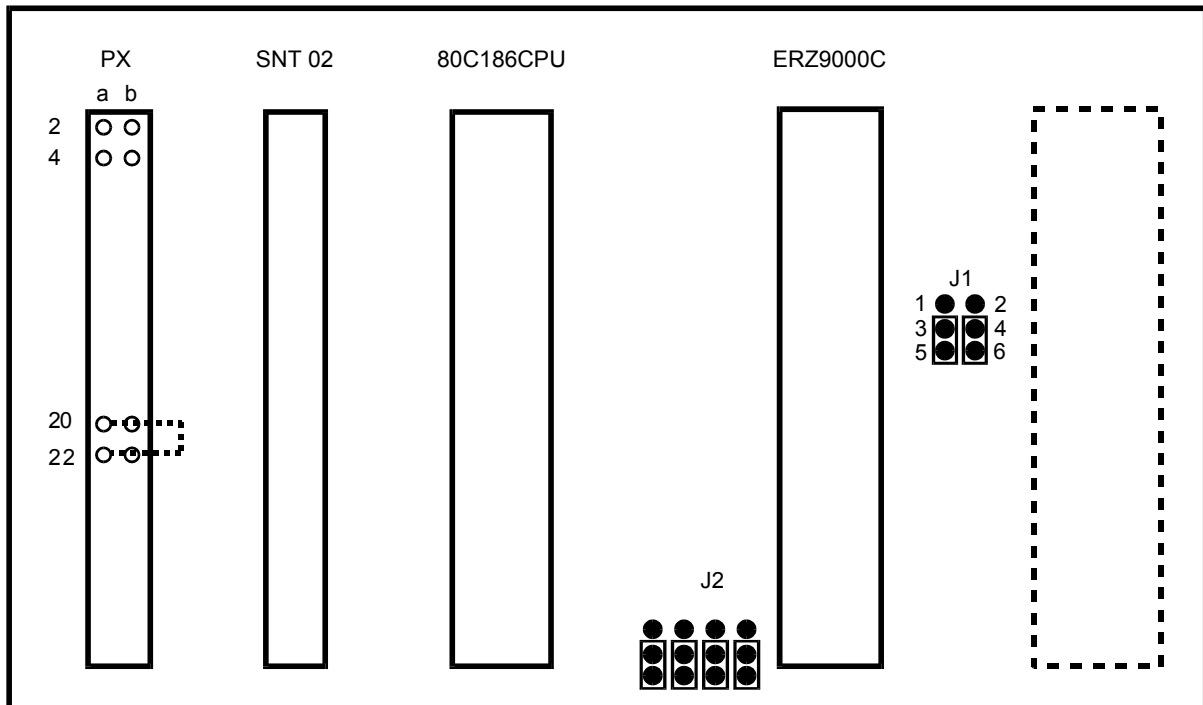

Explosion-proof isolation of pulse inputs - Jumper J1

Setting is to be made via the jumper J1. The following settings are possible:

- 3 - 5: Explosion-proof isolation of the measuring channel is provided outside the ERZ 9000 system.
- 4 - 6: Explosion-proof isolation of the reference channel is provided outside the ERZ 9000 system.
- 1 - 3: Explosion-proof isolation of the measuring channel is provided inside the ERZ 9000 system.
- 2 - 4: Explosion-proof isolation of the reference channel is provided inside the ERZ 9000 system.

Note: For the ERZ 9000 Turbo, explosion-proof isolation is generally provided outside the ERZ system!

Analog GND - Jumper J2

External standby power supply - PX block

In order to operate the ERZ 9000 system with an external standby power supply, it is necessary to set a jumper between the pins 20ab and 22ab on the PX block.

4 Function Charts

4.1 ERZ 9002 T Density Corrector

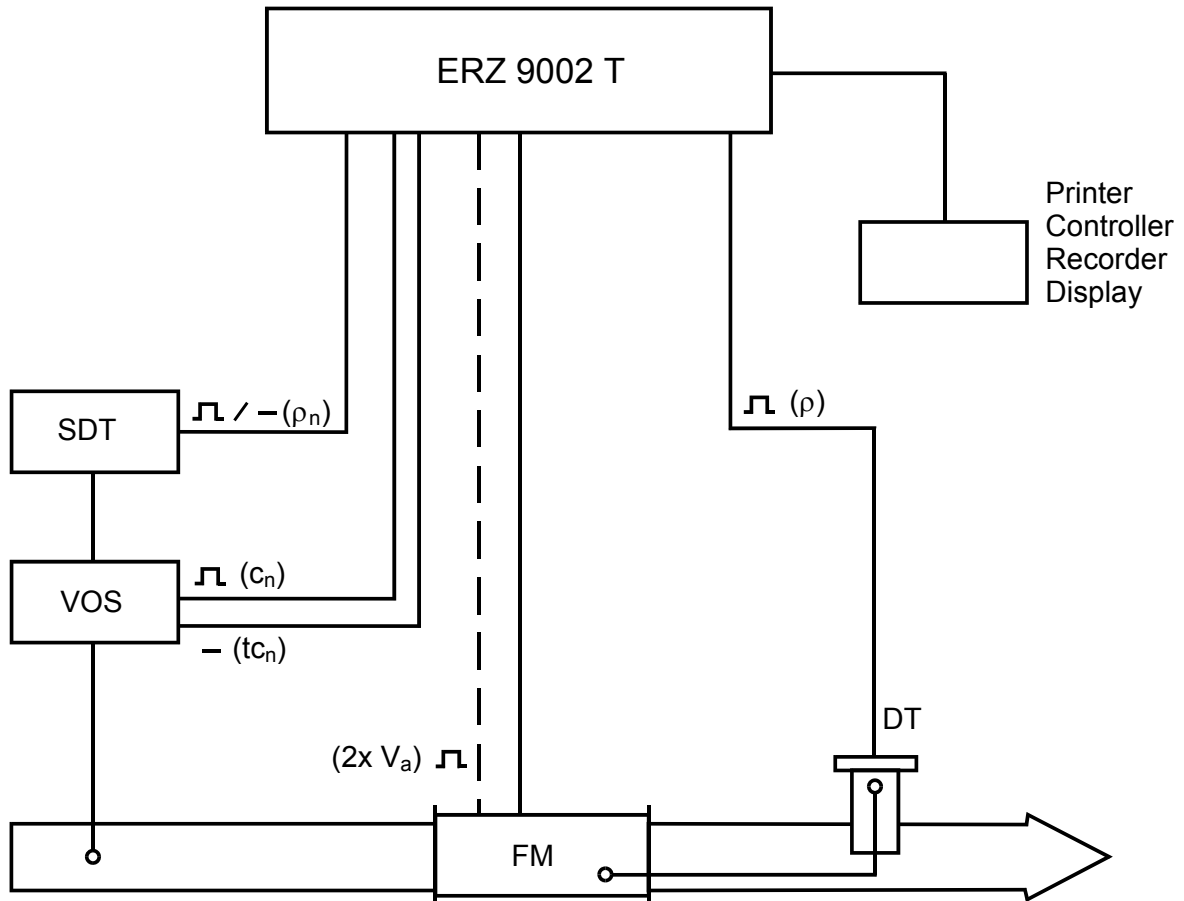

Transmission:

- \square Pulses / frequency
- current

Devices:

- FM = Vortex meter, turbine meter or rotary displacement meter
- VOS = Velocity of sound transducer
- DT = Density transducer
- SDT = Standard density transducer
- ERZ = Computer

Formula:

$$\frac{V_n}{V_a} = VCF = \frac{\rho}{\rho_n}$$

- V_a = Volume at actual conditions (m^3)
- V_n = Standard volume (m^3)
- ρ = Density at actual conditions (kg/m^3)
- ρ_n = Standard density (kg/m^3)
- VCF = Volume correction factor for standard volume calculation

4.2 ERZ 9002/4 T Density Corrector

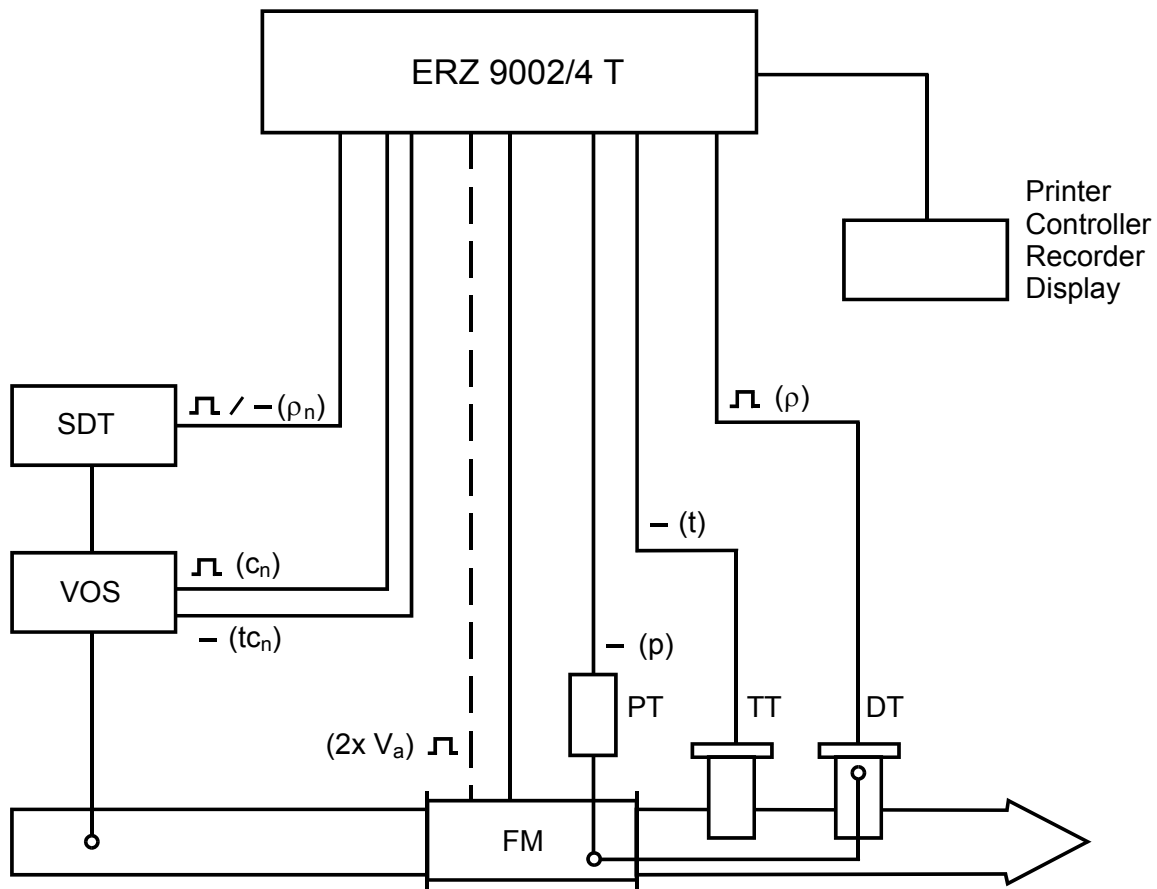

Transmission:

- \square Pulses / frequency
 - Current

Devices:

- FM = Vortex meter, turbine meter or rotary displacement meter
 DT = Density transducer
 VOS = Velocity of sound transducer
 SDT = Standard density transducer
 ERZ = Computer
 PT = Pressure transmitter
 TT = Temperature transmitter

Formula:

$$\frac{V_n}{V_a} = VCF_{(Rho)} = \frac{\rho}{\rho_n}$$

$$VCF_{(p,t)} = \frac{p \cdot T_n}{\rho_n \cdot (T_0 + t) \cdot K}$$

- V_a = Volume at actual conditions (m^3)
 V_n = Standard volume (m^3)
 ρ = Density at actual conditions (kg/m^3)
 ρ_n = Standard density (kg/m^3)
 $VCF_{(Rho)}$ = Volume correction factor for standard volume calculation
 p = Pressure (bar)
 t = Temperature ($^{\circ}C$)
 T_0 = 273.15 (K)
 K = Compressibility factor
 p_n / T_n = Standard pressure / temperature related to 273.15 Kelvin
 $VCF_{(p,t)}$ = Reference volume correction factor via pressure and temperature

4.3 ERZ 9002 TM Mass Corrector

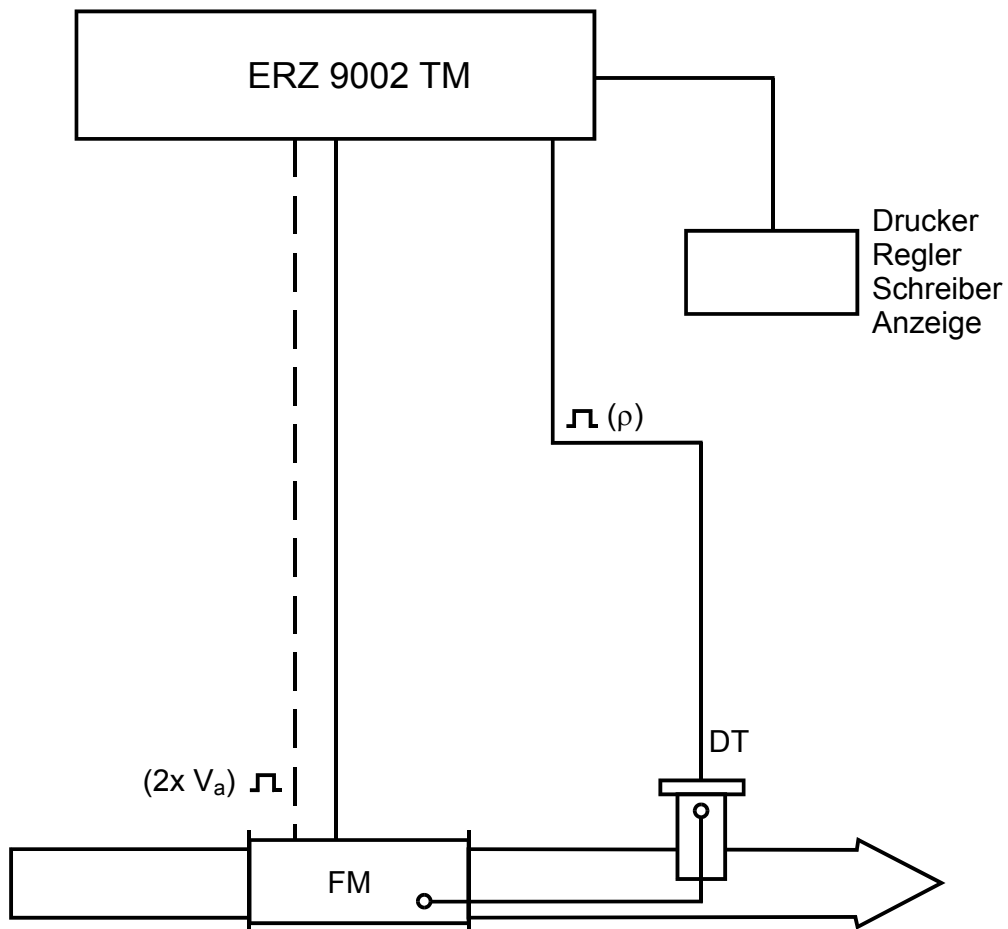

Transmission:

- \square Pulses / frequency
- Current

Devices:

- FM = Vortex meter, turbine meter or rotary displacement meter
- DT = Density transducer
- ERZ = Computer

Formula:

$$M = V_a \cdot \rho$$

- V_a = Volume at actual conditions (m^3)
- M = Mass (kg)
- ρ = density at actual conditions (kg/m^3)

4.4 ERZ 9102 T Superior Calorific Value Corrector

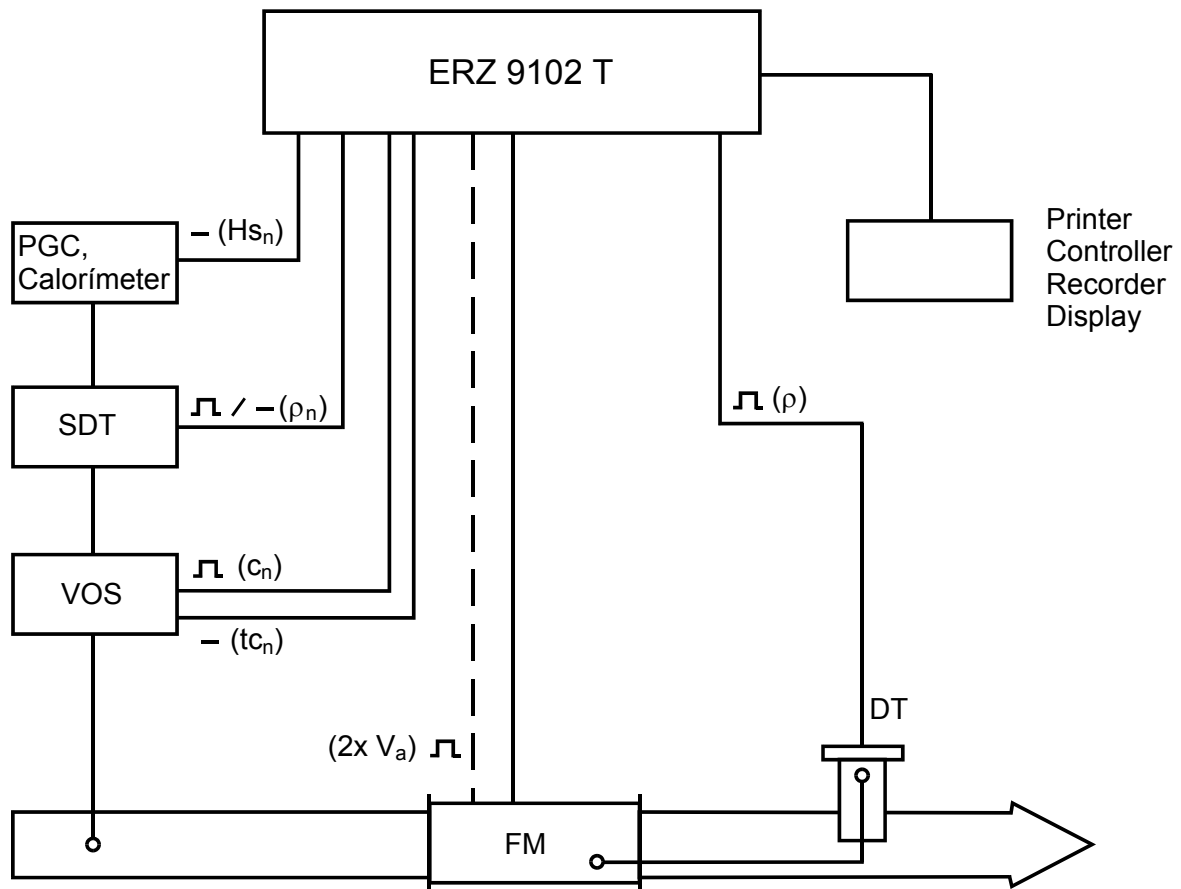

Transmission:

- Pulses / frequency
- Current

Devices:

- FM = Vortex meter, turbine meter or rotary displacement meter
- DT = Density transducer
- VOS = Velocity of sound transducer
- SDT = Standard density transducer
- PGC = Process gas chromatograph
- ERZ = Computer

Formula:

$$\frac{V_n}{V_a} = VCF = \frac{\rho}{\rho_n}$$

$$e = Hs_n \cdot V_n$$

- V_a = Volume at actual conditions (m^3)
- V_n = Standard volume (m^3)
- r = Density at actual conditions (kg/m^3)
- r_n = Standard density (kg/m^3)
- Hs_n = Superior calorific value (kWh/m^3)
- e = Energy (kWh)
- VCF = Volume correction factor for standard volume calculation

4.5 ERZ 9102/4 T Superior Calorific Value Corrector

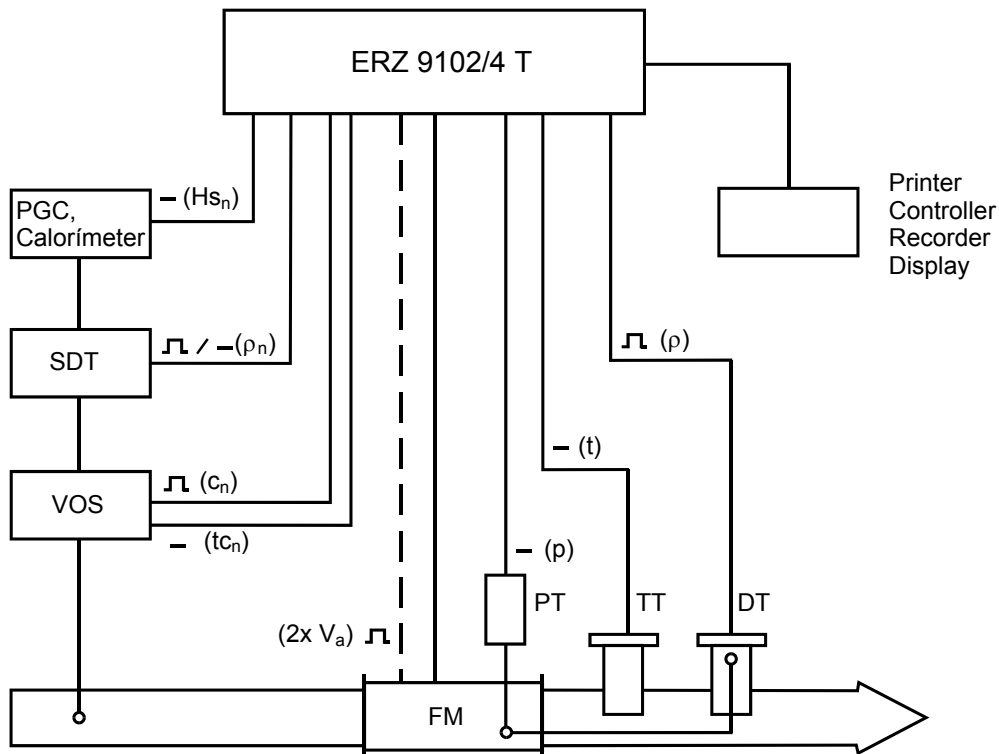

Transmission:

- ▭ Pulses / frequency
- Current

Devices:

- FM = Vortex meter, turbine meter or rotary displacement meter
- DT = Density transducer
- VOS = Velocity of sound transducer
- SDT = Standard density transducer
- PGC = Process gas chromatograph
- ERZ = Computer
- PT = Pressure transmitter
- TT = Temperature transmitter

Formula:

$$\frac{V_n}{V_a} = VCF_{(Rho)} = \frac{\rho}{\rho_n}$$

$$e = Hs_n \cdot V_n$$

$$VCF_{(p,t)} = \frac{p \cdot T_n}{\rho_n \cdot (T_0 + t) \cdot K}$$

- V_a = Volume at actual conditions (m^3)
- V_n = Standard volume (m^3)
- ρ = Density at actual conditions (kg/m^3)
- Hs_n = Superior calorific value (kWh/m^3)
- e = Energy (kWh)
- ρ_n = Standard density (kg/m^3)
- $VCF_{(Rho)}$ = Volume correction factor for standard volume calculation
- p = Pressure (bar)
- t = Temperature ($^{\circ}C$)
- T_0 = 273.15 (K)
- K = Compressibility factor
- p_n / T_n = Standard pressure / temperature related to 273.15 Kelvin
- $VCF_{(p,t)}$ = Reference volume correction factor via pressure and temperature

4.6 ERZ 9004 T Volume Corrector

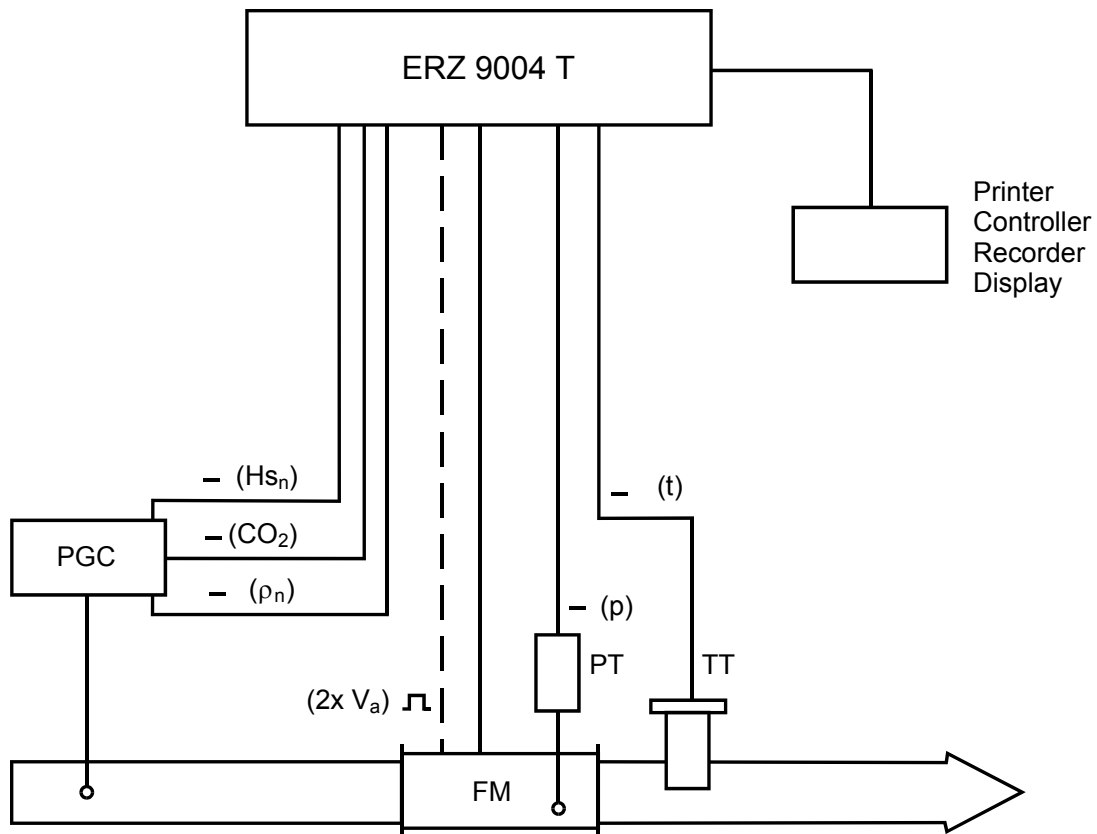

Transmission:

- ⏏ Pulses / frequency
- Current

Devices:

- FM = Vortex meter, turbine meter or rotary displacement meter
- PGC = Process gas chromatograph
- ERZ = Computer
- PT = Pressure transmitter
- TT = Temperature transmitter

Formula:

$$\frac{V_n}{V_a} = VCF = \frac{p \cdot T_n}{p_n \cdot (T_0 + t) \cdot K}$$

- V_a = Volume at actual conditions (m^3)
- V_n = Standard volume (m^3)
- p = Pressure (bar)
- t = Temperature ($^{\circ}C$)
- T_0 = 273.15 (K)
- K = Compressibility factor
- H_{s_n} = Superior calorific value (kWh/m^3)
- ρ_n = Standard density (kg/m^3)
- p_n / T_n = Standard pressure / temperature related to 273.15 Kelvin
- VCF = Reference volume correction factor

4.7 ERZ 9104 T Superior Calorific Value Corrector

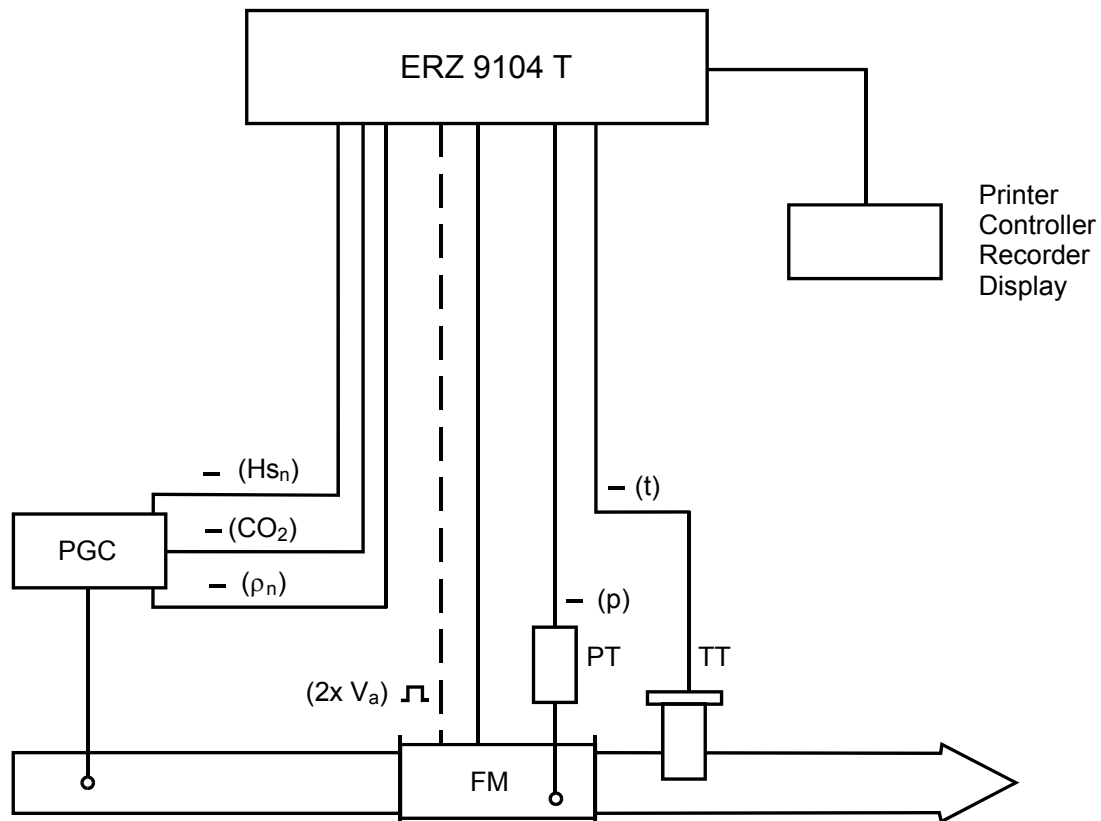

Transmission:

- ⏏ Pulses / frequency
- Current

Devices:

- FM = Vortex meter, turbine meter or rotary displacement meter
- PGC = Process gas chromatograph
- ERZ = Computer
- PT = Pressure transmitter
- TT = Temperature transmitter

Formula:

$$\frac{V_n}{V_a} = VCF = \frac{p \cdot T_n}{p_n \cdot (T_0 + t) \cdot K}$$

$$e = Hs_n \cdot V_n$$

- V_a = Volume at actual conditions (m^3)
- V_n = Standard volume (m^3)
- e = Energy (kWh)
- p = Pressure (bar)
- t = Temperature ($^{\circ}C$)
- T_0 = 273.15 (K)
- K = Compressibility factor
- Hs_n = Superior calorific value (kWh/ m^3)
- ρ_n = Standard density (kg/m^3)
- p_n / T_n = Standard pressure / temperature related to 273.15 Kelvin
- VCF = Reference volume correction factor

5 Construction

5.1 Technical data

Accuracy

$\leq 0.1\%$ of the measured value in the range from -20°C to $+60^{\circ}\text{C}$.

Ambient temperature

Max. ambient temperature from -20°C to $+60^{\circ}\text{C}$.

Inputs

Analog inputs: 14½-bit resolution. Accuracy ± 1 bit, measuring period approx. 100 ms.

Volume frequency: 16-bit resolution. Range: 0.05 Hz to 20 kHz or metering from 0 Hz.

Frequency inputs: 23-bit resolution; range from 0.05 Hz to 25 kHz.

Digital inputs: Status signals, passive contact mechanism (relay or open collector); load 5 V, 20 mA.

Status signals: $t_{d_{high}} > 1\text{ s}$ $t_{d_{low}} > 1\text{ s}$

Outputs

Analog outputs: 14±1-bit resolution, load 800 ohms, electrically isolated.

Digital outputs: Limiting value 24V 100mA
Dispatcher
Minimum pulse width adjustable from 50 ms (10 Hz) to 300 ms (1.5 Hz).
Output frequency from 0 to 10 Hz, electrically isolated open collector.
Totalizer pulses
Pulse width approx. 150 ms (3 Hz), pulse width not adjustable.
Electrically isolated open collector.
Limit contacts
Electrically isolated open collector.
Fault / Warning
Relay contacts (closed-circuit principle).

Power supply

Switched-mode power supply unit with 40 kHz clock frequency. All secondary voltages are electrically isolated from each other. Charging unit for standby battery.

Stand. power supply unit: 24 V DC (21 V to 27 V), power input approx. 35 W

Special version: 230 V AC (-10% to +6%), power input approx. 35 W

Internal battery: The standby battery sustains the power supply of the ERZ 9000T including (option) transducers / transmitters for approx. 30 minutes. After a discharge, the battery attains its full power after approx. 10 hours.

Display field and keypad

2-line luminescent display in blue with 20 characters per line.

Digit height 5 mm, 7 x 5 dot matrix.

Luminosity 856 cd/m².

Temperature range from -10°C to +60°C.

Front panel film with short-stroke keys.

CPU

CPU 1: 80C537 / 12 MHz (standard)

Memory areas:

a) Custody transfer metering data:	non-volatile memory C-MOS, 2 kBytes
b) User data:	non-volatile memory C-MOS, 2 kBytes
c) Totalizer memory:	non-volatile memory C-MOS, 512 Bytes
d) Program memory:	EPROM 64 / 128 kBytes

CPU 2: 80C186 / 10 MHz (Turbo extension)

Data memory: 64 / 256 kBytes
+ 2kByte DPRAM

Program memory: 64 / 786 kByte EPROM + 8 kByte EEPROM

Weights & measures

Rack-mounting unit: Height 3 units, width 213 mm, depth 310 mm
weight excl. battery approx. 3.2 kg, weight incl. battery approx. 4.0 kg

Wall-mounting unit: Height 245 mm, width 340 mm, depth 260 mm
weight excl. battery approx. 3.7 kg, weight incl. battery approx. 4.5 kg

Interfaces of the rack-mounting unit

Front panel:	<u>Front interface</u> RS 232 C as service interface 9-pin subminiature Cannon connector transmission rates from 300 to 9600 baud 1 start bit, 1 stop bit, 8-bit data, no parity
Rear panel:	<u>C1 interface</u> RS 232 C as service or printer interface 9-pin subminiature Cannon connector transmission rates from 2400 to 19200 baud 1 start bit, 1 stop bit, 8-bit data, no parity
	<u>C2 interface</u> RS 485 C as DSfG interface 9-pin subminiature Cannon connector transmission rates from 2400 to 19200 baud 1 start bit, 8-bit data parity bit setting: off / even / odd stop bit setting: 1 / 2
	<u>C3 interface</u> RS 232 C for connection to FE 06 9-pin subminiature Cannon connector transmission rates from 1200 to 19200 baud 1 start bit, 8-bit data parity bit setting: off / even / odd stop bit setting: 1 / 2
	<u>C4 & C5 interfaces</u> RS 232 C — spare — 9-pin subminiature Cannon connectors transmission rates from 1200 to 19200 baud 1 start bit, 8-bit data parity bit setting: off / even / odd stop bit setting: 1 / 2

Interfaces of the wall-mounting unit

Front panel:	<u>Front interface</u> RS 232 C as service interface 9-pin subminiature Cannon connector transmission rates from 300 to 9600 baud 1 start bit, 1 stop bit, 8-bit data, no parity
Terminal compartment:	<u>Terminal compartment interface</u> Max. one interface. Screw terminals in the terminal compartment. The interfaces C1 through C5 are available. The desired interface must be wired, as appropriate.

5.2 Mode of operation

Pulse counting / pulse frequency measurement block diagram

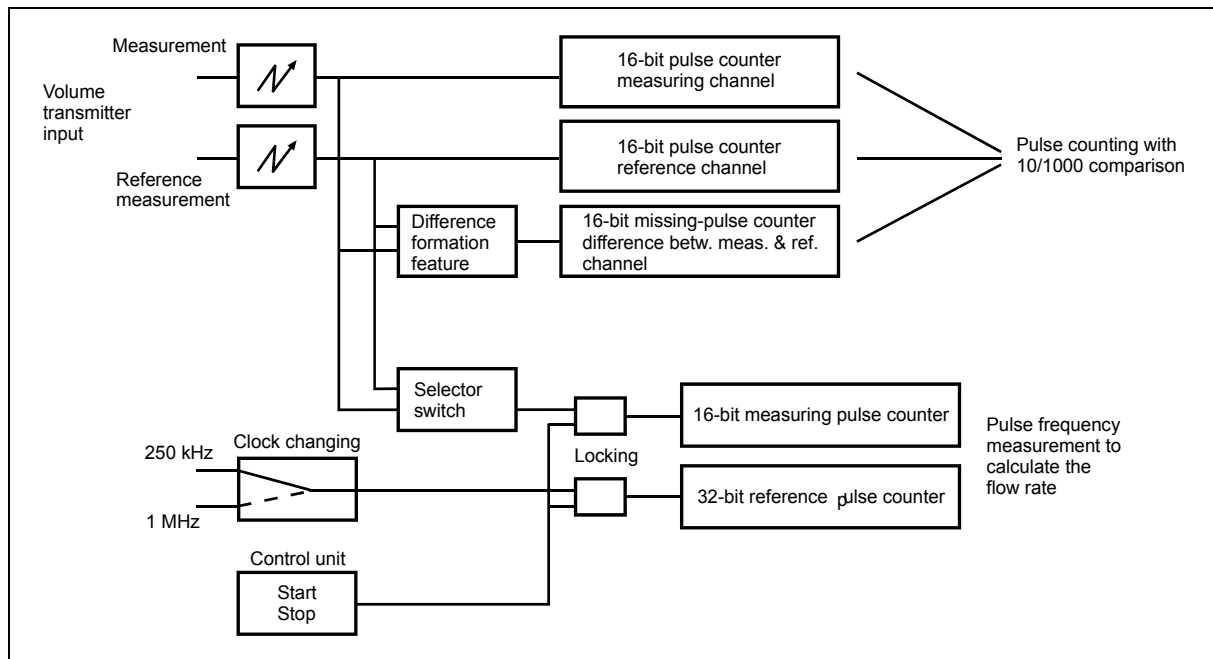

Description of pulse counting

Pulse counting is based on two channels, but can be switched to one-channel mode. The measuring channel and the reference channel are separated from each other.

1:1 operating mode

There is the same number of pulses per time unit (or per rotation of the turbine wheel) on both channels. The input pulses must be out of phase (90° to 270°). The difference formation feature alternately compares the measuring and reference pulses. Every deviation is counted by the missing-pulse counter. If the preset limiting value (e.g. 10 pulses) is exceeded, an alarm is tripped. If the limiting value is not exceeded within a presettable period (e.g. 10000 pulses), the missing-pulse counter is set to zero.

X:Y operating mode

The number of pulses per time unit (or per rotation of the turbine wheel) is not the same on both channels. The input pulses may have any phase angles. Differences are formed only via the software. The deviation results from the ratio of the measuring wheel and reference wheel parameters inputted. In the event of a deviation $> 4\%$, an alarm is tripped.

Description of pulse frequency measurement

To calculate the flow rate, the frequency of volume pulses is determined by means of a period measurement. A selector switch samples the measuring and reference channels in such a way that a frequency and thus a volume flow rate can be determined from both pulse frequencies (irrespective of the mode 1:1 or X:Y). Clock frequency changing (250 kHz / 1 MHz) allows to change the measuring resolution or the measuring period in connection with the chosen volume transmitter (vortex meter = long gate time).

Measurable frequency, min.: 0.05 Hz
Measurable frequency, max.: 20 kHz

Storing quantity pulses / Electronic totalizers

The counted and evaluated pulses are stored threefold in a non-volatile memory (C-MOS RAM). A cyclic 1-out-of-3 comparison checks the contents of the memory locations for equality. In the event of one value deviating from the other two values, an alarm is tripped and the wrong value is overwritten with the contents of the coinciding memory locations. This applies to all V_a , V_n and V_e totalizers.

Frequency measurement block diagram

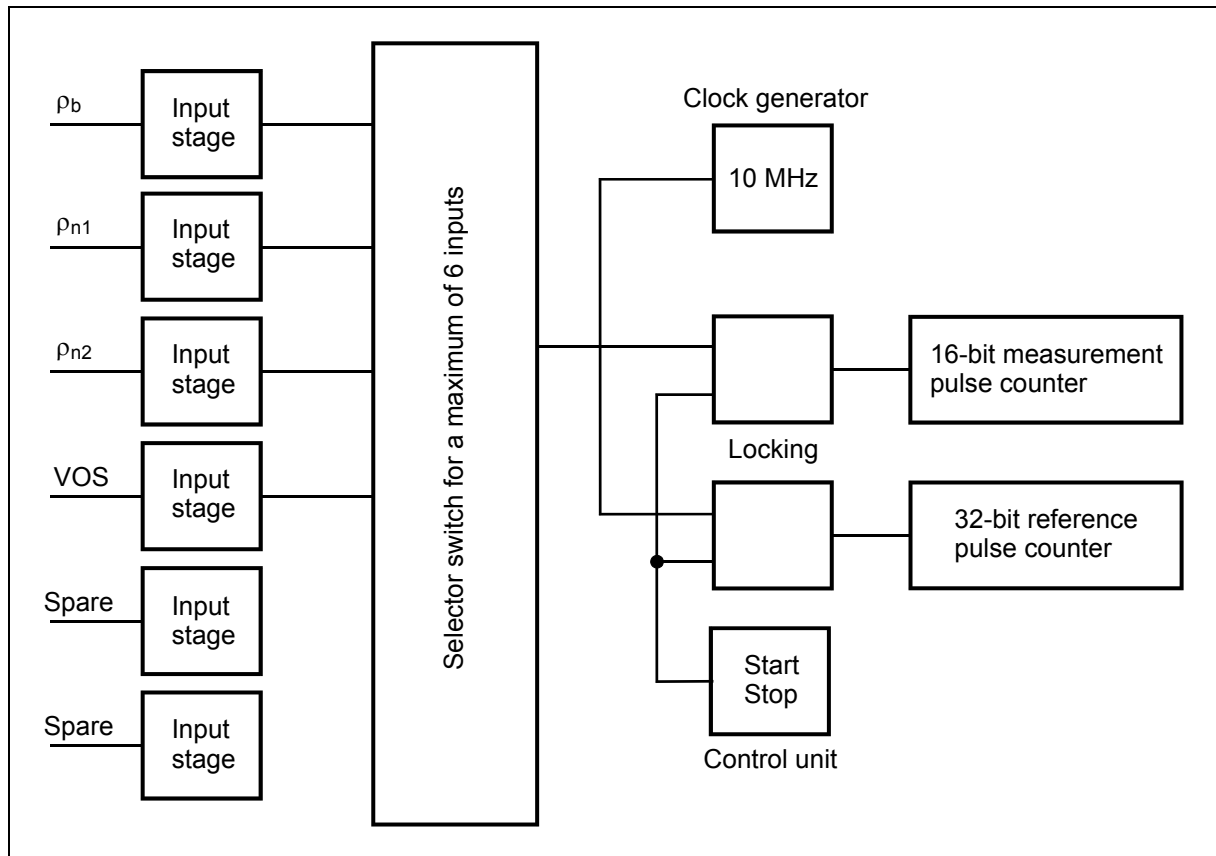

Description of frequency measurement

To carry out density or sound velocity calculations, it is necessary to measure the frequency of the transducers connected. A selector switch samples the inputs connected. The measuring pulse counter has a resolution of 16 bits, whereas the reference pulse counter has a resolution of 32 bits.

Measurable frequency, min.: 0.05 Hz
 Measurable frequency, max.: 25 kHz

Block diagram of analog inputs

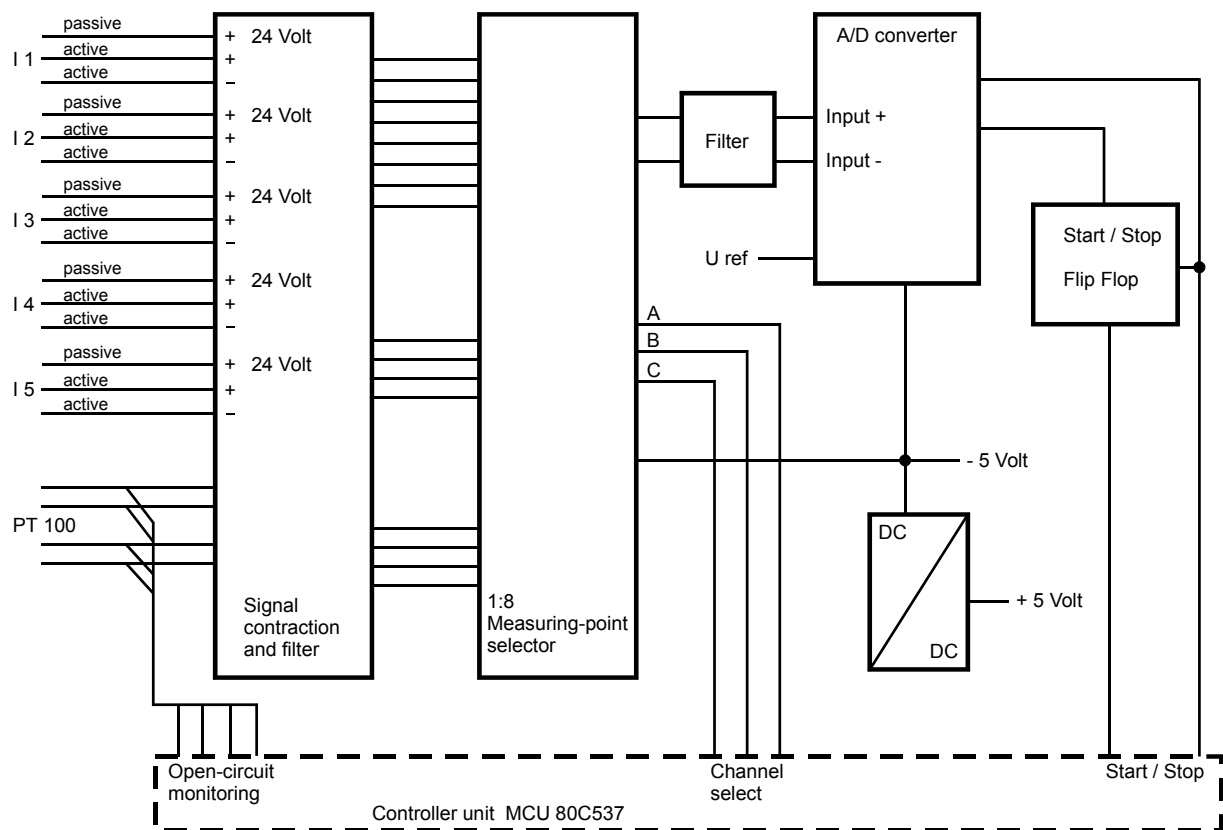

Analog inputs

Dual-slope analog-digital converter with $14\frac{1}{2}$ -bit resolution corresponding to 20000 steps. A multiplexer which can sample a maximum of 6 analog inputs is located upstream of the A/D converter. Five inputs are designed for current measurement and one input for resistance measurement using four-wire technology with open-circuit monitoring.

Analog outputs

Digital-analog converters with 14-bit resolution. There is one electrically isolated converter for each current output.

Interfaces

Interfaces without handshake lines; communication is made via Xon / Xoff. The rack-mounting unit is fitted with two 9-pin subminiature Cannon connectors, whereas the wall-mounting unit has one 9-pin connector on the front panel and one screw terminal in the terminal compartment. Including back-up fuse, varistor and transient absorber (TAZ diode).

Optional battery standby supply

Internal battery (option)

The standby battery sustains the power supply of the ERZ 9000 T and the transducers for approx. 30 minutes if it is fully charged. Charging the battery takes approx. 10 hours.

Block diagram

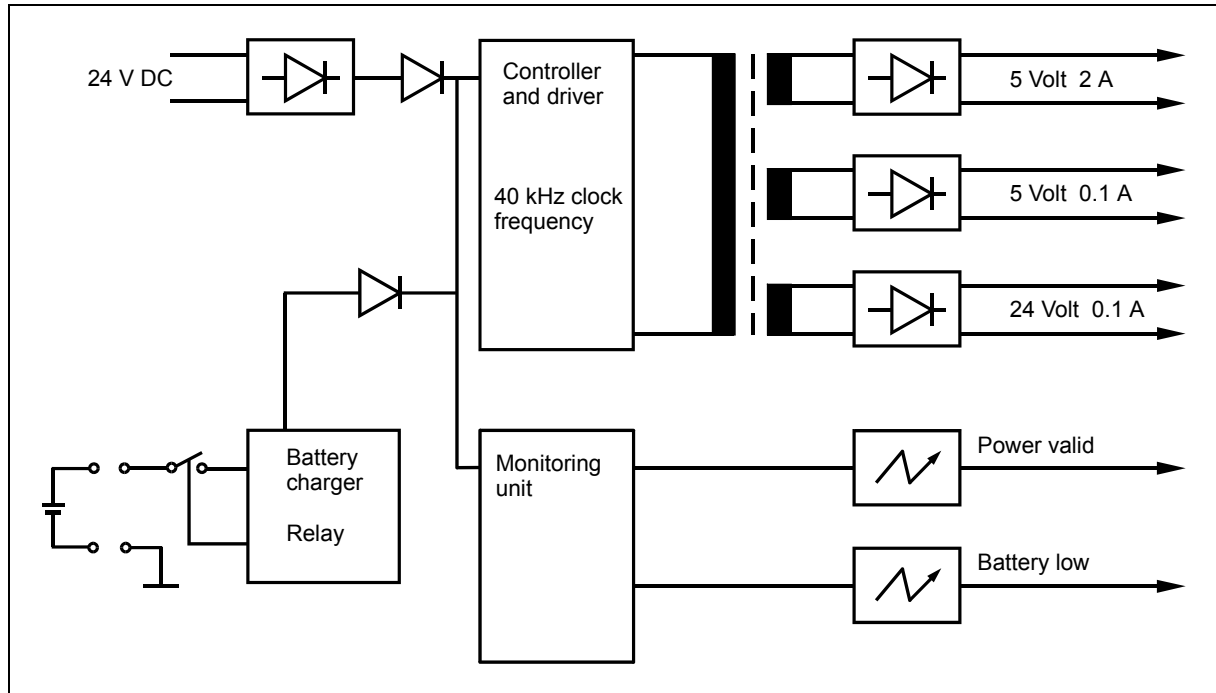

Activation of the internal battery

To activate the internal battery, set the following jumper:

- Rack-mounting unit: Connector J4, jumper between 9 and 10.
- Wall-mounting unit: Jumper between A2 and A6.

External battery

If an external battery is installed, we would recommend using 2 series-connected lead-gel batteries (8 V-1.1 Ah). The charging voltage of the ERZ 9000 T is 18.2 V. When choosing the batteries, make sure that trickle charging is possible. If this is not possible, the batteries must be loaded regularly, i.e. loading the battery by disconnecting the device from the power supply.

Activation of the external battery

To activate the external battery, set the following jumper:

- Rack-mounting unit: Set a jumper on the soldering point P14 of the plug-in assembly.
- Wall-mounting unit: Set a jumper between the contacts 20ab and 22ab on the PX block of the plug-in assembly.

In order to ensure that the battery will sustain the power supply of the device in the event of a power failure, the device must be operated once with 24 V or 230 V.

6 General Wiring Instructions

PE - GND connection

On the rear panel, there are the PE terminals for applying the shields. These terminals are only connected to the case or the PE conductor. There is no connection to the GND of the corrector. When carrying out installation, make sure that additionally a connection is made between the shield (PE) and GND (refer also to the pin assignment diagrams of the inputs):

Wall-mounting unit (connector J5):	wire jumper between pins 10 & 11
Wall-mounting unit:	wire jumper between C15 and C7

Connecting cables and applying shields

Shields are to be applied via feed-through terminals to the transducers/transmitters from the ERZ 9000 T. If an electrical isolation is available in the mounting rack as explosion-proof interface, shields are to be applied to the side which is not explosion-proof of the ERZ 9000 T alone. Refer to the wiring diagrams of the mounting rack concerned for applying shields to the explosion-proof side. If a cabinet from RMG Messtechnik is used, refer to the pertinent wiring diagrams.

As a rule, shields are to be applied to the corrector or mounting rack, with the exceptions of the DG 08 and the NDG 08, where shields must start in the top case (already internally wired in the case of the NDG 08), pass via feed-through terminals and end on the mounting rack (interface).

Shields should be applied to one side only. If it becomes necessary due to measurement- or fault-related reasons to apply the shield to both sides, make sure that a separate line will be installed for equipotential bonding.

7 Pin Assignment Diagrams

7.1 Rear panel of the rack-mounting unit

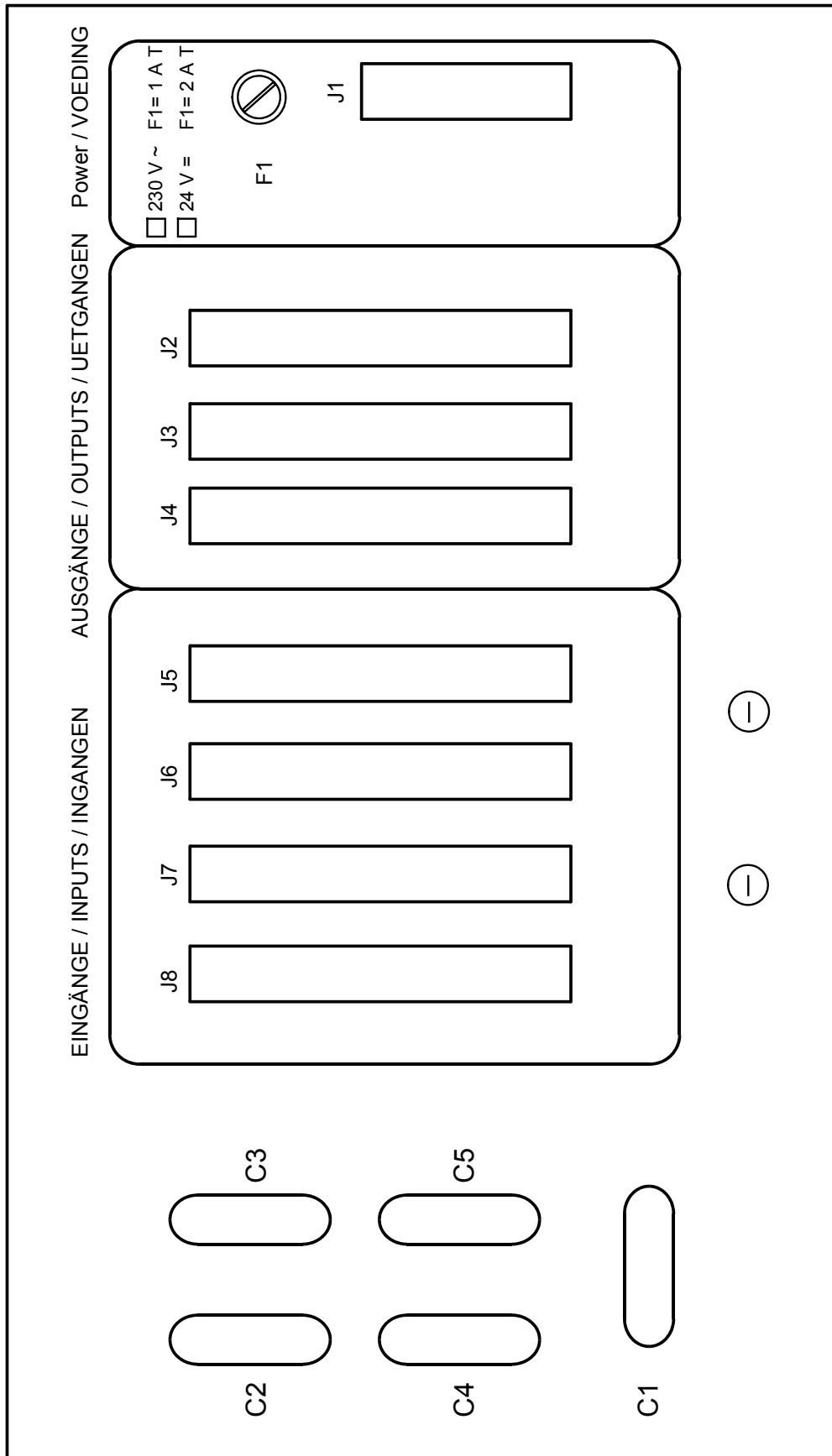

- C1: Service or printer interface
- C2: DSfG interface
- C3: Connection to FE-06
- C4: Spare
- C5: Spare

7.2

Terminal assignments for the inputs of the rack-mounting unit

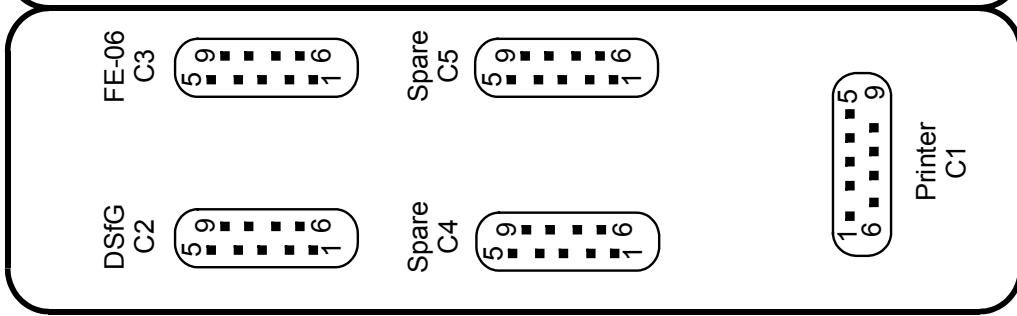
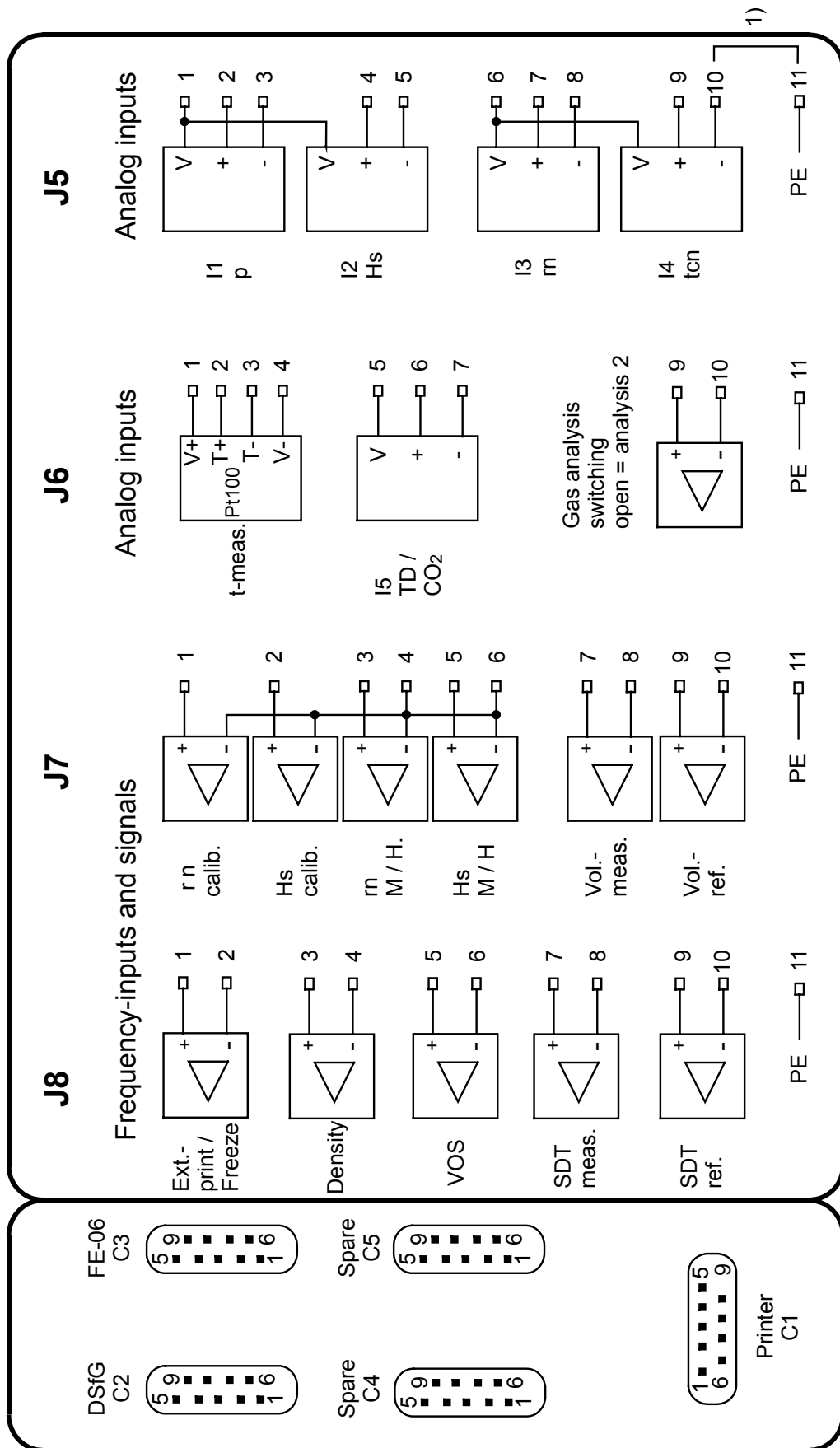

- J7 - 1 calibrating rn
- J7 - 2 calibrating Hs
- J7 - 3 checking rn (measuring / holding)
- J7 - 5 checking Hs (measuring / holding)
- J8 - 1/2 selectable via **MODE**

1) Set jumper externally

7.3 Terminal assignments for the outputs of the rack-mounting unit

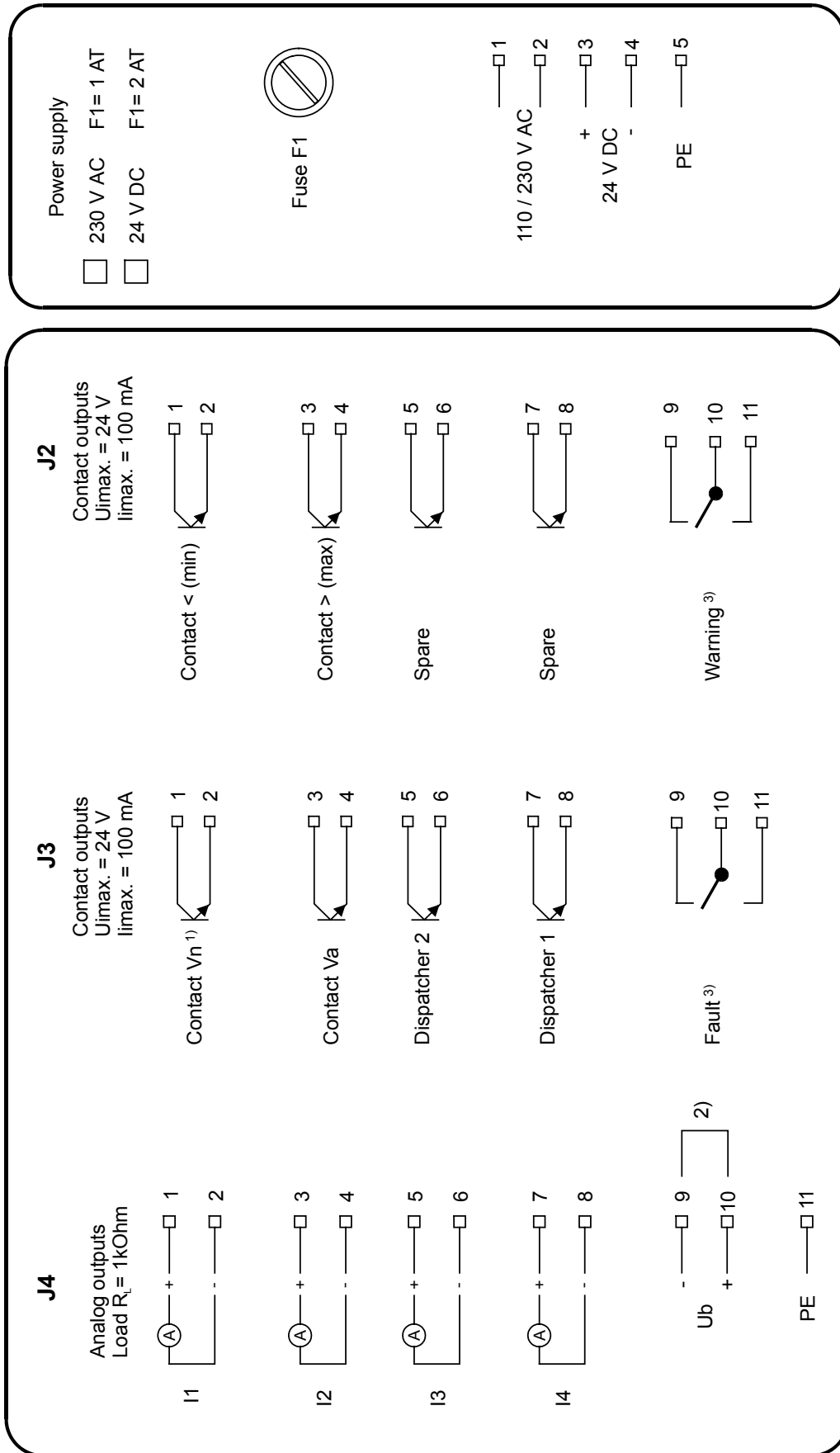

- 1) Model ERZ 9002TM: Contact E (earth).
- 2) When using an internal battery, set a jumper between the contacts 9 and 10. When using an external battery, set the soldering jumper P14 in the ERZ 9000 (see "Technical Data").
- 3) In the event of fault-free operation, the fault / warning relays are picked up (contacts J3 / (9-10) and J2 / (9-10) are closed). If a fault occurs and or if the device is disconnected from the power supply, the relays release (contacts J3 / (10-11) and J2 / (10-11) are closed).

7.4 Terminal assignments for the inputs of the wall-mounting unit

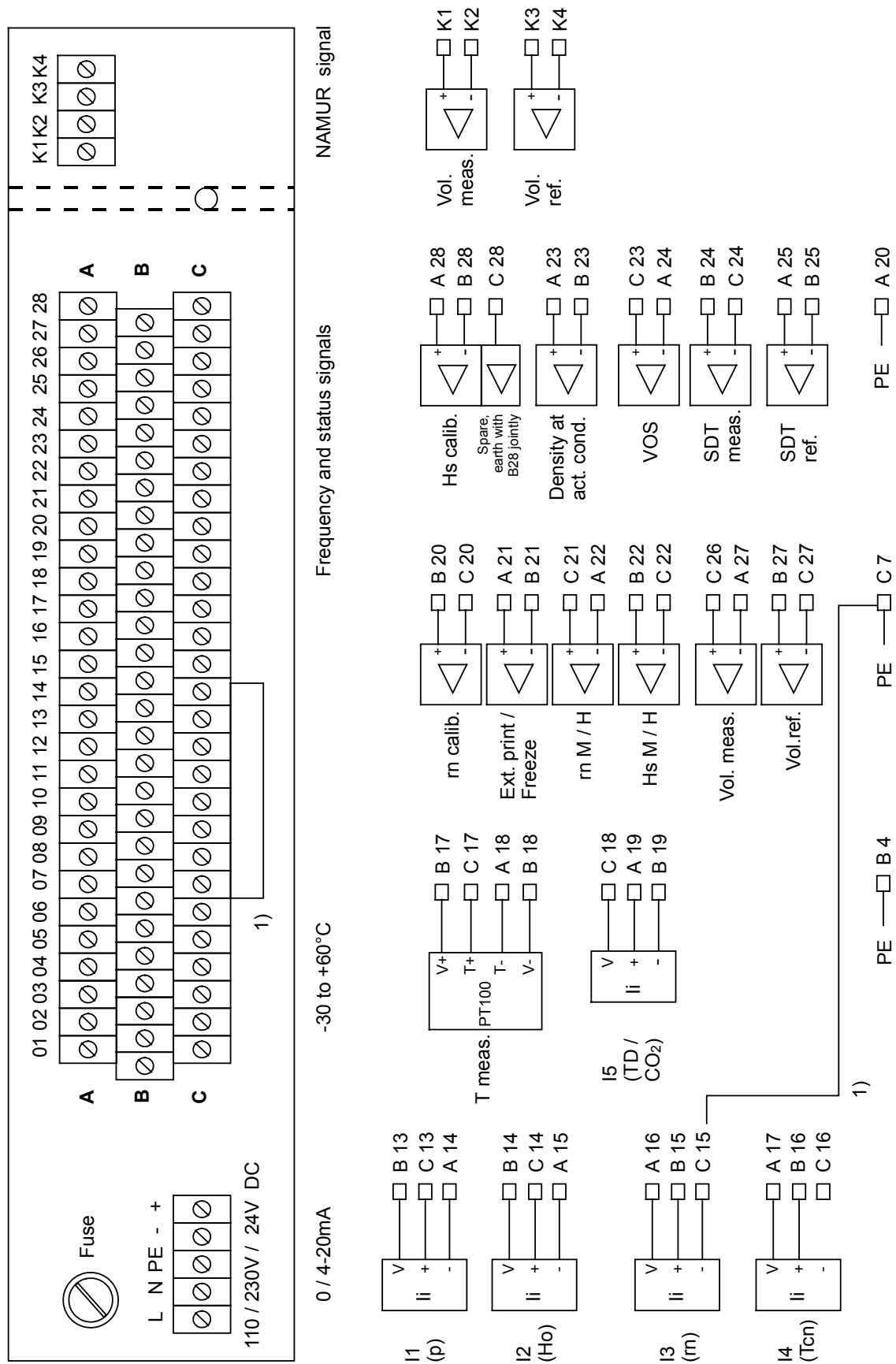

1) Set jumper externally.

7.5 Terminal assignments for the outputs of the wall-mounting unit

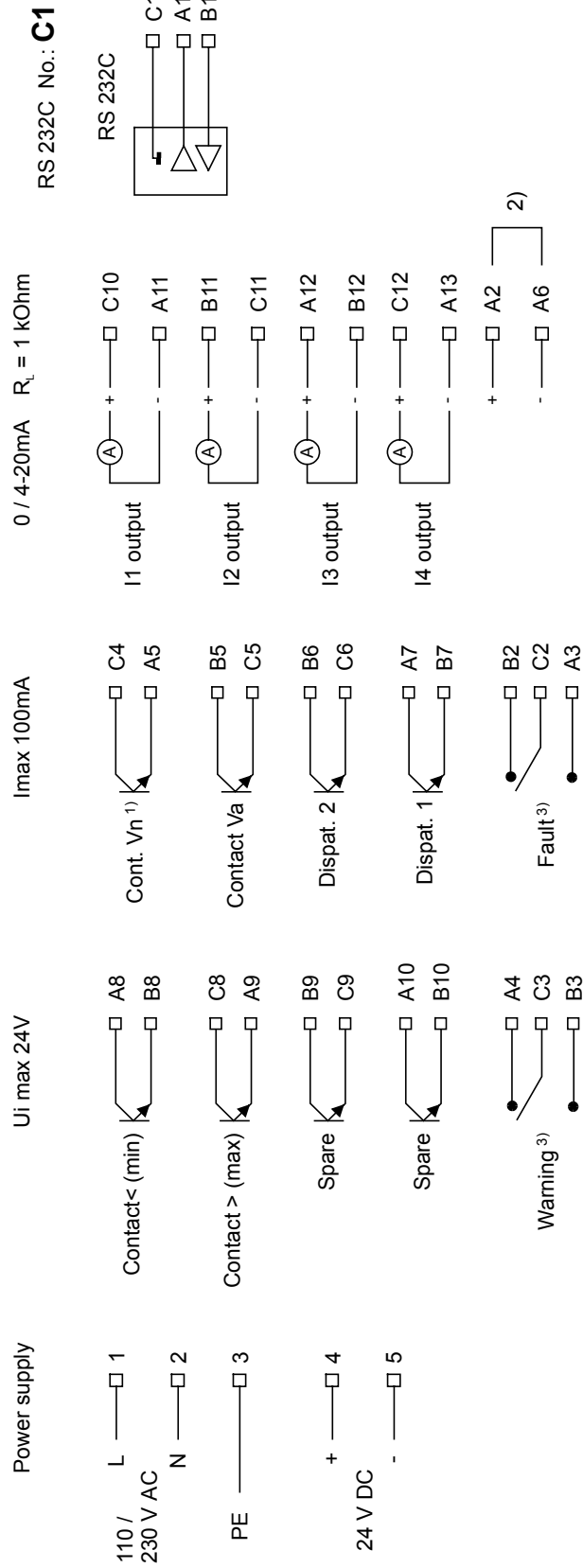
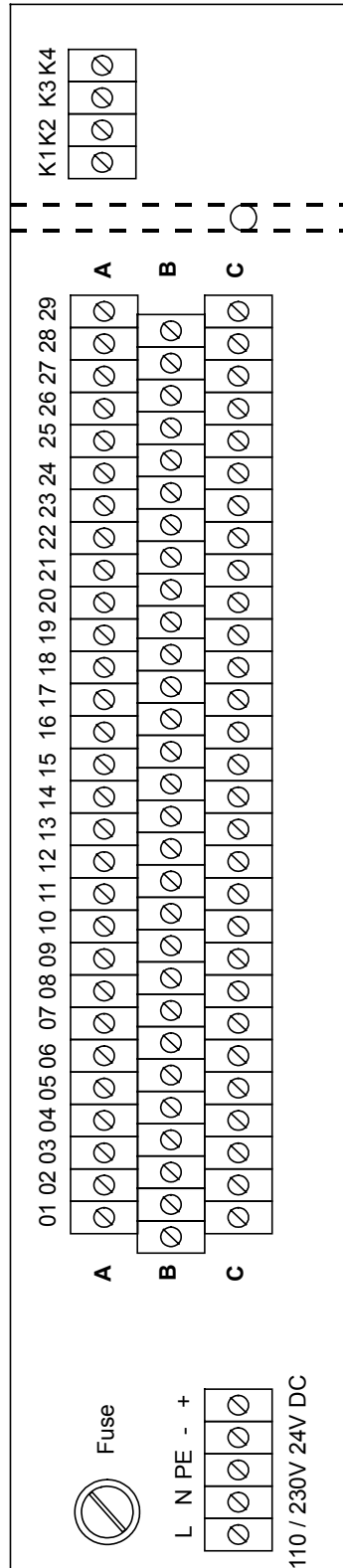

- 1) Model ERZ 9002 TM: contact E (earth).
- 2) When using an internal battery, set a jumper between the contacts A2 and A6. When using an external battery, set the soldering jumper P14 in the ERZ 9000 (see "Technical data").
- 3) In the event of fault-free operation, the fault / warning relays are picked up (contacts B2-C2 and A4-C3 are closed). If a fault occurs or if the device is disconnected from the power supply, the relays release (contacts C2-A3 and C3-B3 are closed).

8 Wiring Examples

8.1 Input for pressure transmitter

Passive current input

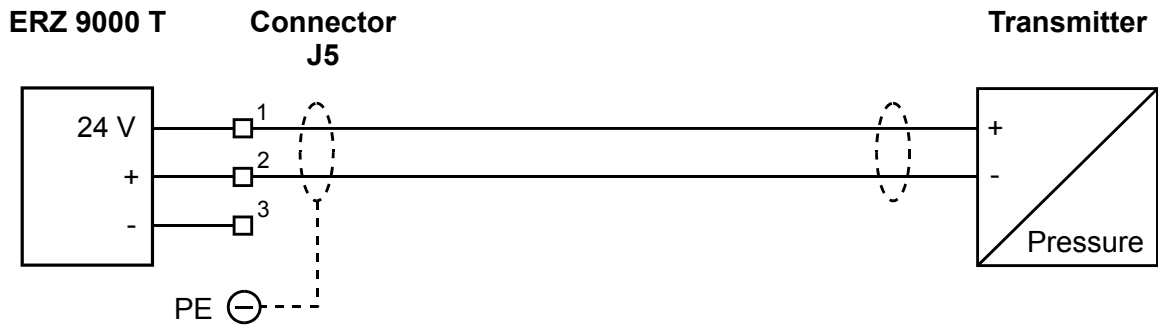

Active current input

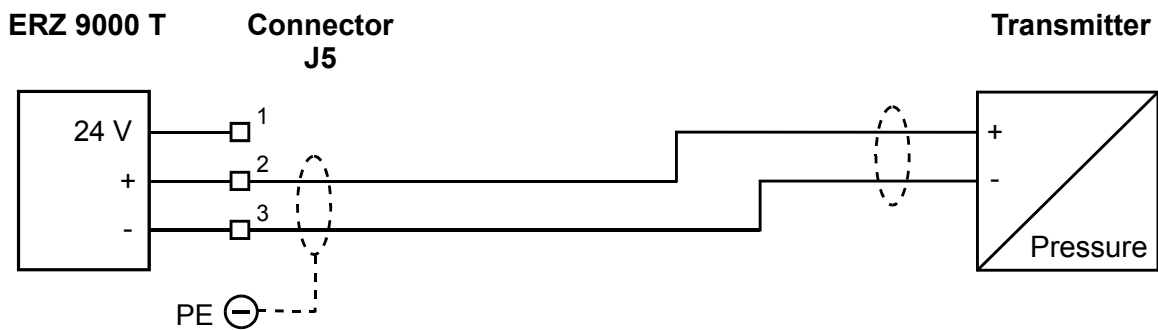

8.2 Input for temperature transmitter

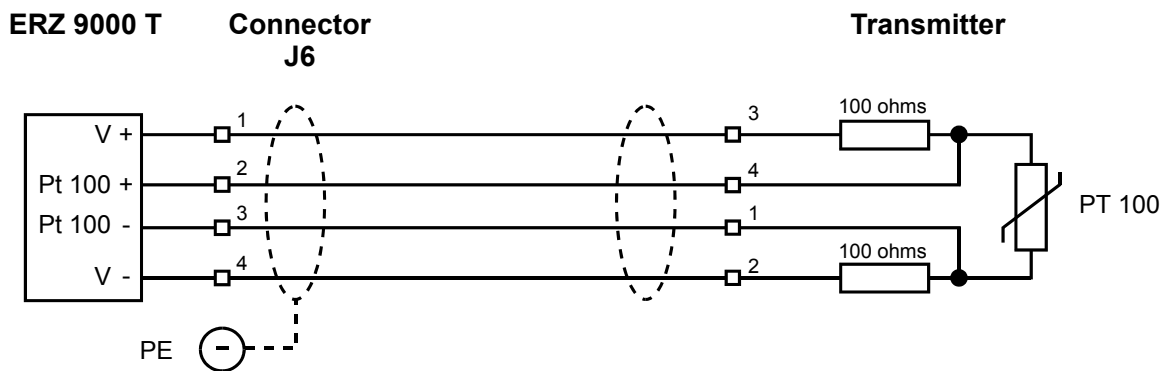

8.3 Input for density transducer, Type DG 08

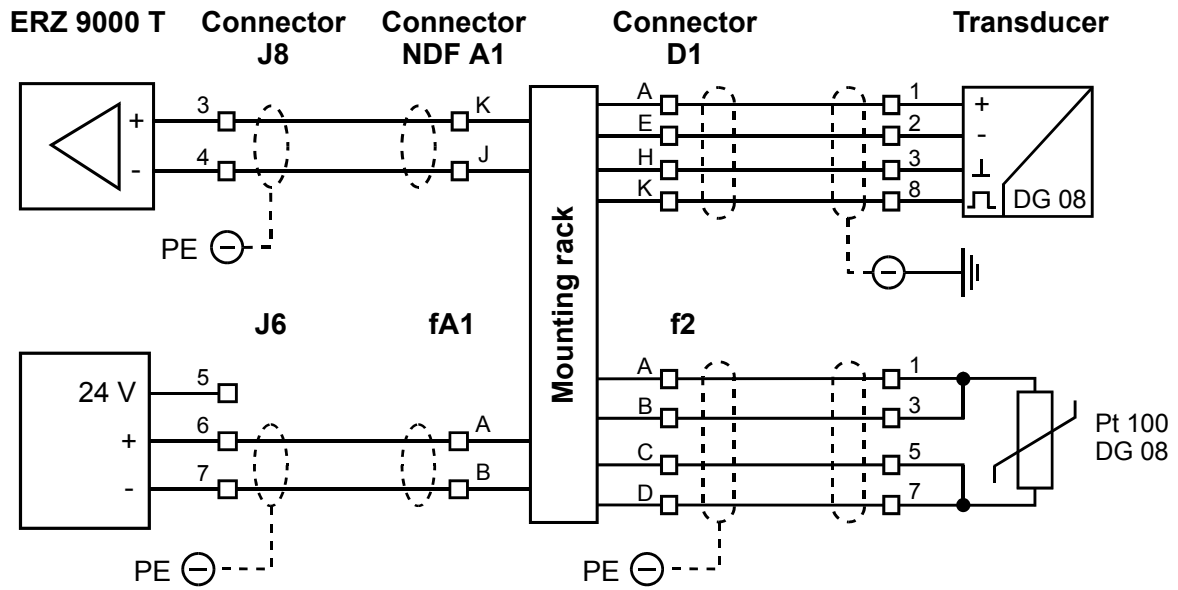

8.4 Input for standard density transducer, Type NDG 08

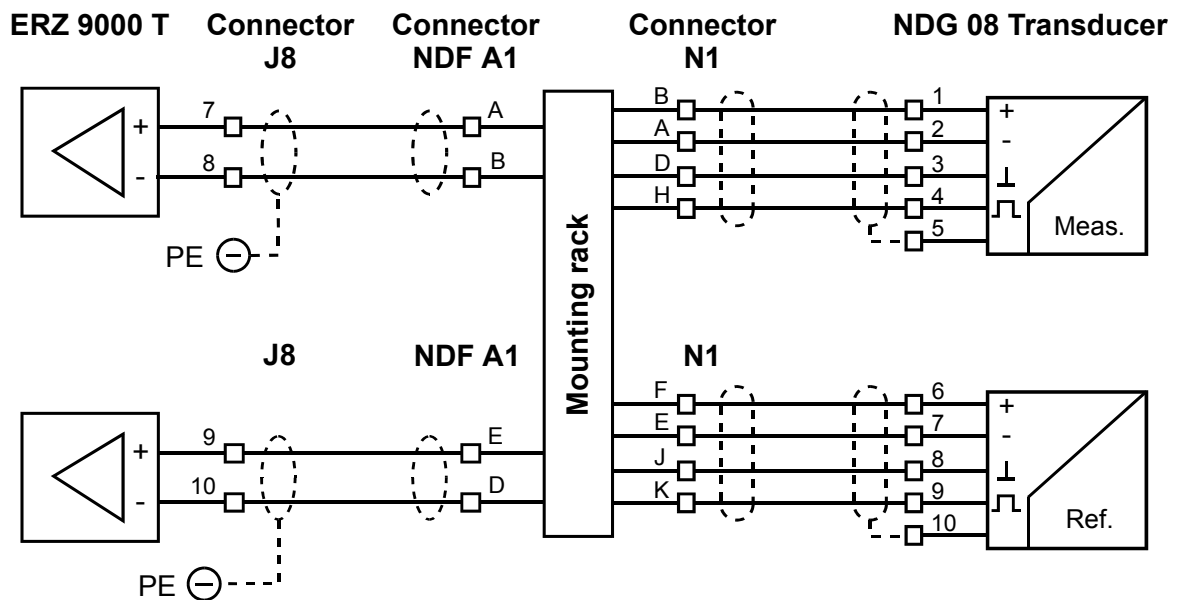

8.5 Input for velocity of sound transducer, Type VOS 07

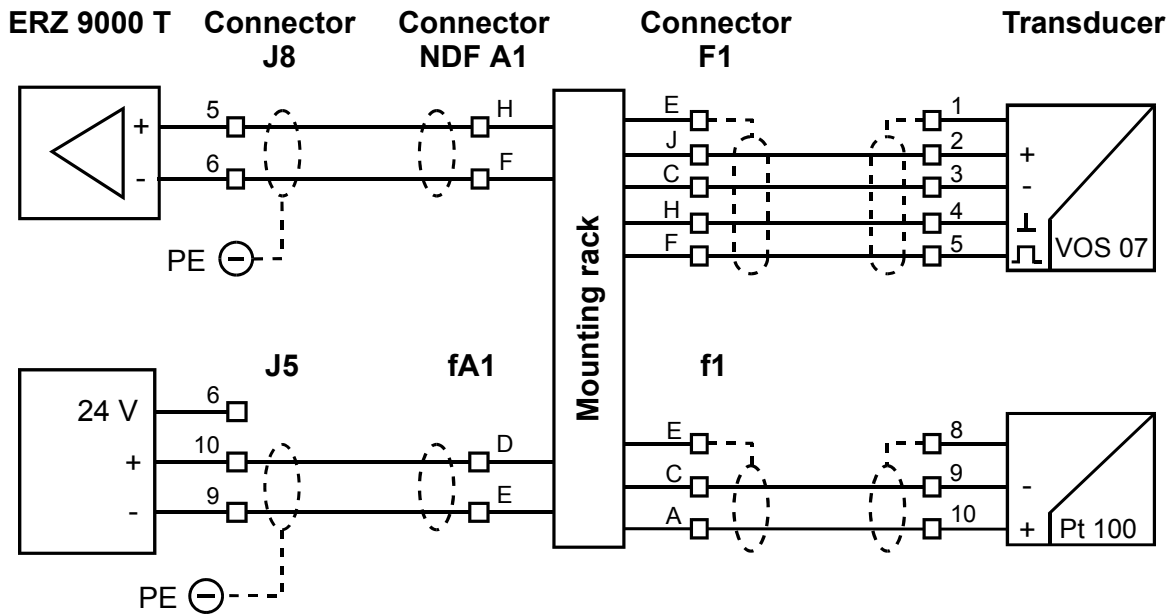

8.6 Input for ρ_n / H_s correction

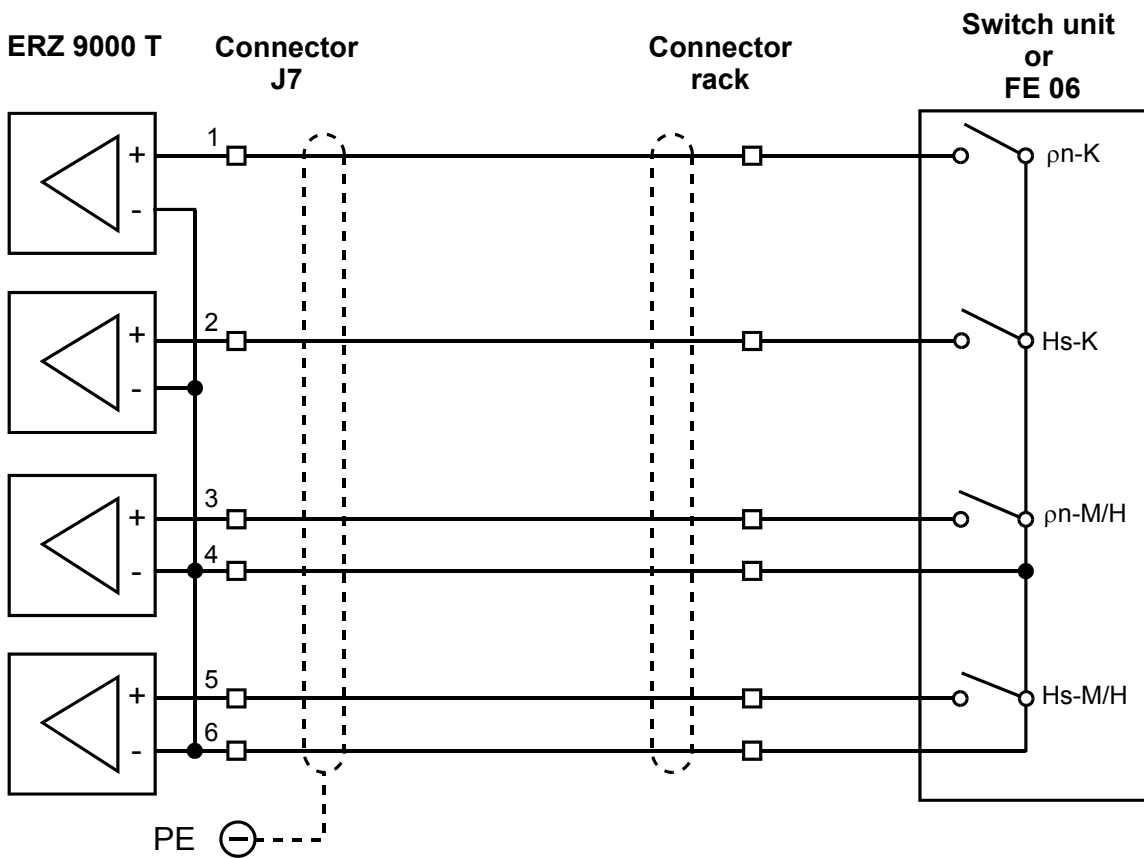

8.7 Input for volume measurement

Vortex meter

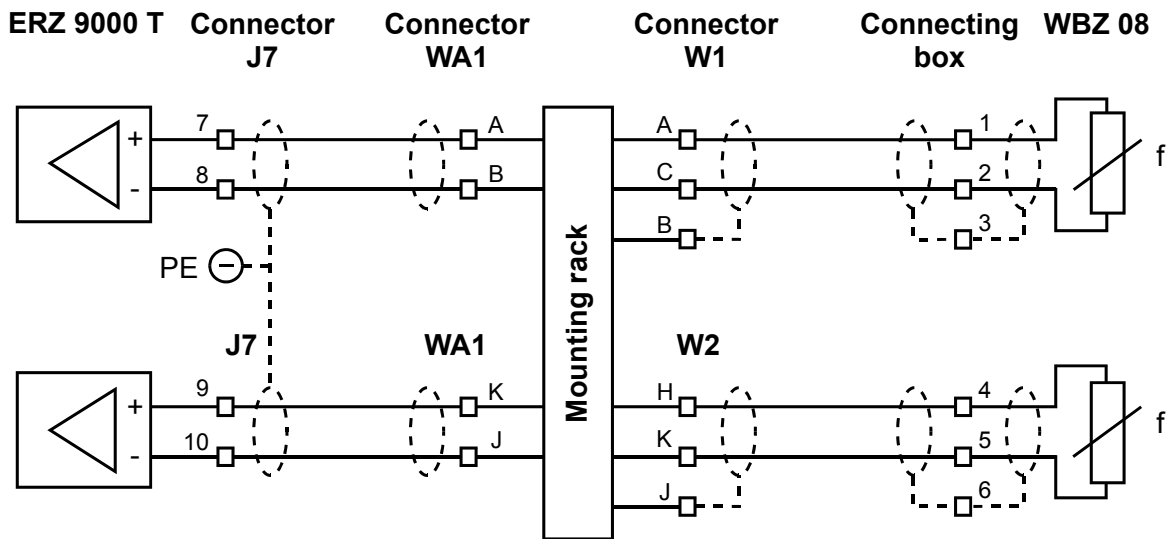

Turbine meter

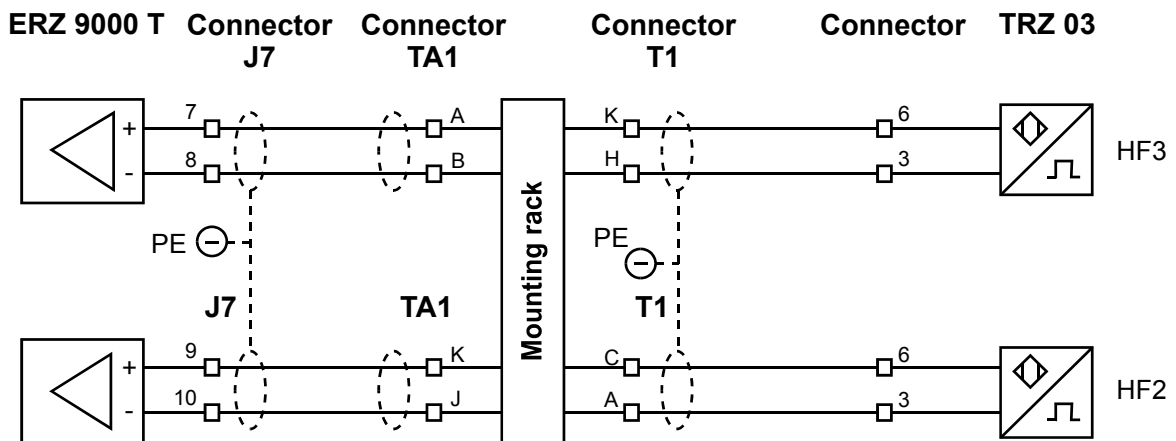

8.8 Analog output

Example: Analog output 1

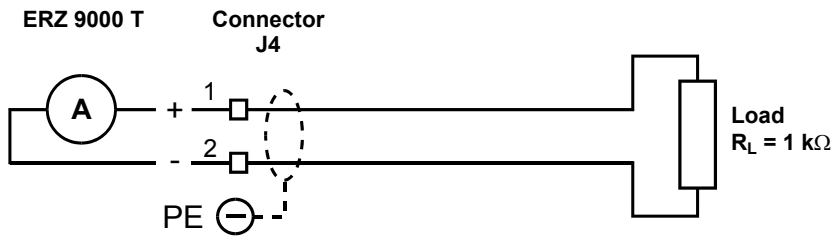

8.9 Relay output

Example: Fault output

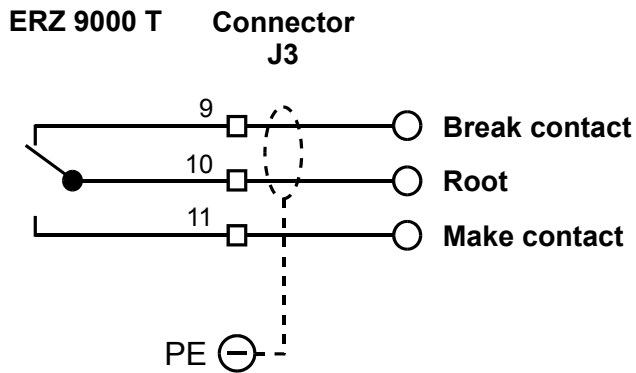

8.10 Optocoupler output

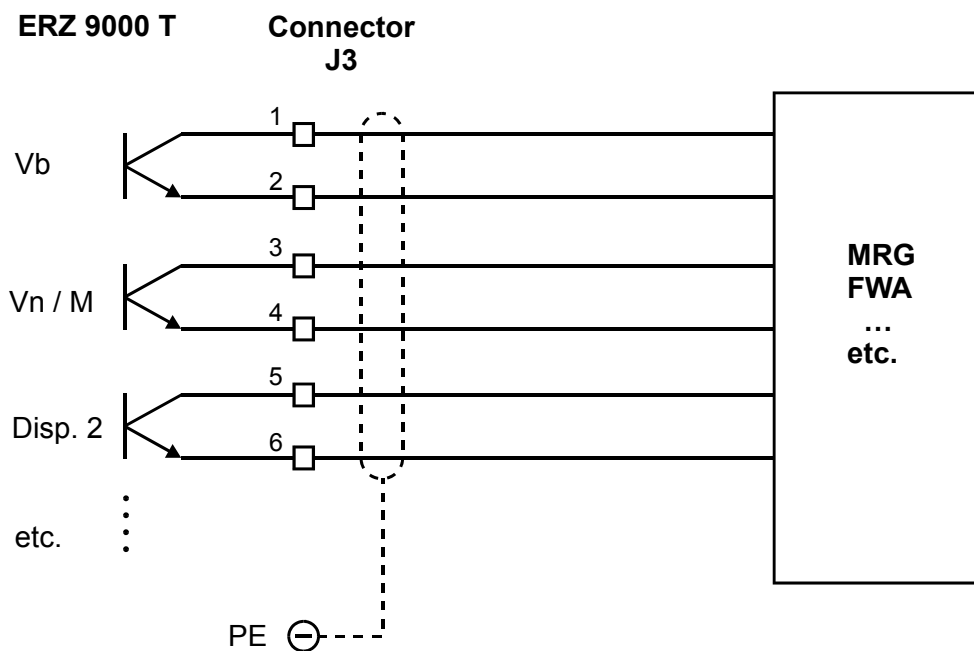

9 DSfG Extension

All devices of the ERZ 9000 T generation have been prepared for operation on the DSfG bus and can be upgraded accordingly. For this purpose, the DSfG adaptor is plugged onto the turbo card and connected to the C2 interface connector using a ribbon cable. The interface is to be set in the field T.

Setting parameters:

Bit rate: normally, 9600 baud.

DSfG address: Transport address (1 - 31) of the corrector.

Source address: Transport address of the device being linked up with the corrector.

Preset: The preset is any digit used for coding the data of the corrector.

Source preset: The source preset is the preset of the device being linked up with the corrector.

Software

The status of the software corresponds to the present-day status of specifications of DVGW working committees.

Hardware

The hardware complies by 100% with DSfG standards.

Example of a typical DSfG configuration:

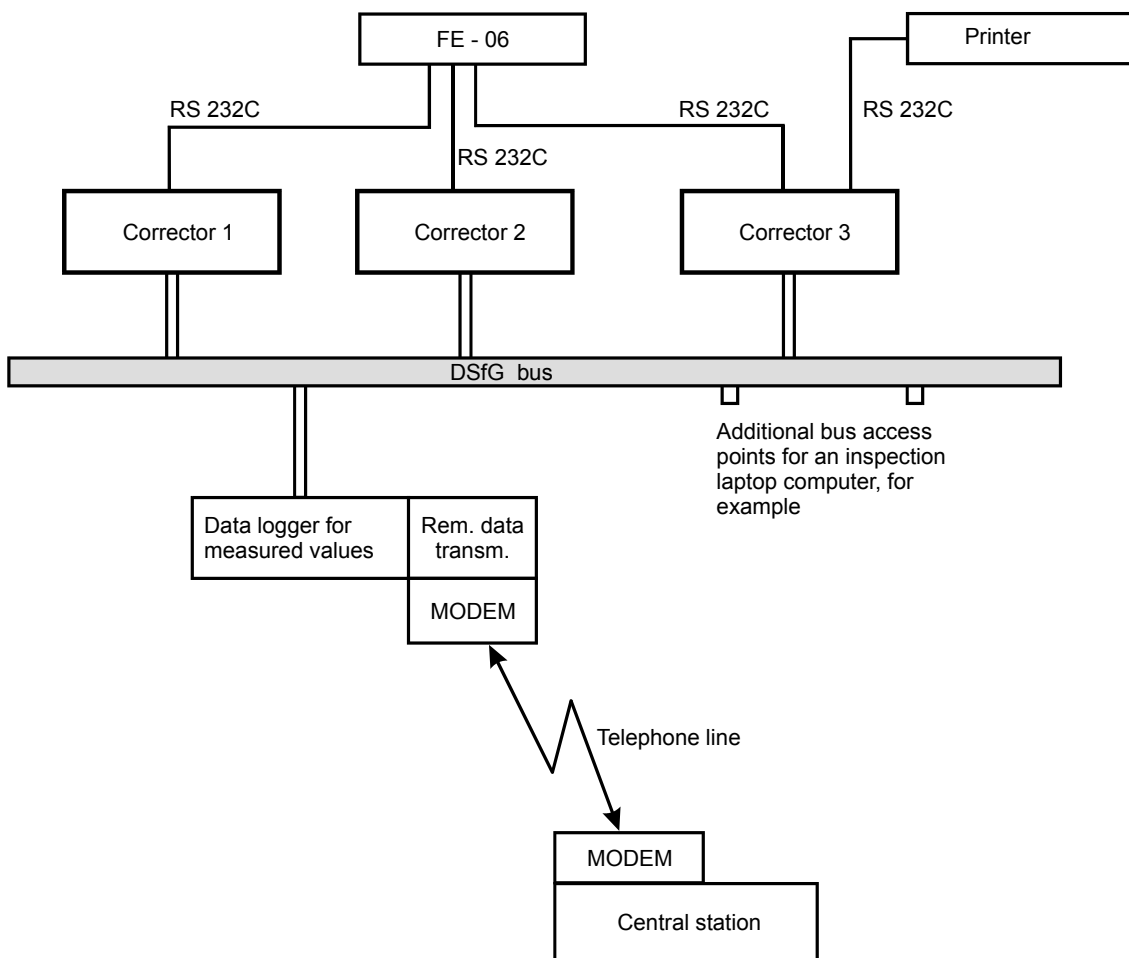

Electrical characteristics

As to its electrical characteristics, the DSfG interface is based on the EIA RS 485 standard (differential voltage signals via a twisted pair of wires). The DSfG network with its scheduled bus topology makes it possible to connect up to 31 users. The length of the bus (main bus line) may be up to 500 m. The individual DSfG users are to be interfaced with the bus via spur lines with a maximum length of 5 m.

Connector pin assignments

On the side of the ERZ 9000T, the DSfG interface has been designed as a 9-pin male Cannon connector. Provide the spur line with a 9-pin female connector and screw it together with the device connector. Contact assignments are as defined in the table below:

Pin No.	Signal	Description
1	+U	Optional power supply (+5 V DS) for external power supply of the bus
2	GND	Reference potential of the electronic interface system, electrically isolated from the device
3	R/TA	"A" wire of the pair of wires
4		not assigned
5	SGND	Reference potential of the bus connection, identical to GND
6	-U	Reference potential of +U, identical to GND
7	GND	Reference potential of the electronic interface system, electrically isolated from the device
8	R/TB	"B" wire of the pair of wires
9	PE	Earth of the device, potential equal to protective earth

Assign the pins 1, 3, 5 and 8 for wiring the female connector to the spur line.

There is the possibility for connecting bus power supply, generation of open-circuit potential and a bus terminating resistor in the device concerned via switches. In order to avoid that the calibration seal must be opened only to actuate these switches when installing the bus, all correctors are supplied with **switched off** switches. The terminating resistors and the generation of open-circuit potential are to be connected externally, while the power supply of the bus is to be preferably provided by the control station (i.e. the bus master of the protocol layer 2). This may be the data logger for measured values or the remote data transmission unit.

Bus cable

The bus spur line serves as a connection between the device and the bus. There are 9-pin female Cannon connectors available on both sides of the cable with a maximum length of 5 m. The cable contains 2 pairs of wires which are twisted together and shielded in each case. The nominal cross section per wire must be at least 0.14 mm², while the capacitance must be below 150 pF/m.

In most cases, the shield is connected on one side to the metal core of the female connector. This single-sided connection of the shield is required to avoid earth loops. In order to prevent interfering radiation, further measures may be necessary in the individual case, such as double-sided shielding and, parallel to this, separate potential equalization.

The main bus cable, whose total length is limited to 500 m, contains two pairs of wires. Each pair of wires is twisted together and shielded. The nominal cross section per wire must be greater than 0.25 mm², while the capacitance must be below 150 pF/m. The shield of the main bus cable is to be connected at one point (preferably at the end) to a bonding strip. Even here it applies that in order to prevent interfering radiation, further measures may be necessary in the individual case, such as double-sided shielding and, parallel to this, separate potential equalization.

Bus termination and generation of open-circuit potential

In order to prevent distortion and reflection of signals, terminating resistors must be connected on both sides of the bus cable. These terminating resistors should correspond more or less to the wave impedance of the line with typical values between 120 and 150 ohms. In addition to the terminating resistors, there is at least one network necessary for generating the open-circuit potential (2×470 ohms). The basic circuit is illustrated by the following figure:

