

Transmitter Unit for Totalizer Readings ENCO – F/M



OPERATING INSTRUCTIONS

**Serving the Gas
Industry Worldwide**

Note:

Unfortunately, paperwork does not automatically update itself but technical developments are constantly being made. Therefore, we reserve the right to change the descriptions and statements contained in our operating instructions without prior notice. However, you can conveniently download the most recent version of this manual (and those of other devices) from our website www.rmg.com.

RMG Messtechnik GmbH

Otto-Hahn-Str. 5

35510 Butzbach (Germany)

Fax: +49 (0)6033 897-130

E-mail: RS-HPS-Messtechnik@Honeywell.com

Phone numbers:

Switchboard: +49 (0)6033 897-0

Customer Service: +49 (0)6033 897-127

Spare Parts: +49 (0)6033 897-173

INTRODUCTION	1
FUNCTIONAL DESCRIPTION	2
Application	2
Method of operation	3
Schematic sketch of the ENCO – F.....	3
Schematic sketch of the ENCO – M	4
Block diagram for the ENCO – F/M.....	4
SAFETY INSTRUCTIONS	5
INSTALLATION	6
Electrical connections	6
Cable gland	10
START-UP	11
Initializing the device	11
Setting the totalizer reading	11
Parameterizing the ENCO-F:	11
Parameterizing the ENCO-M:.....	11
Parameterizing the gas volume corrector	12
Connecting the gas flow	12
OPERATION	13
Display	13
Programming	14
Principle of programming	16
Display values	17
Displaying faults and events	17
Parameters and modes of the ENCO	18
Meter factor (pulse value, A06)	18
Configuration (A09)	19
Pulse monitoring	21
Detection of the direction of rotation	21
Flow rate at 4 mA	21
Flow rate at 20 mA	21
Current default value (calibration current).....	21
Current output mode.....	21
Current damping	22
Correction factors for current offset and current rise.....	22
Parameters for the ENCO	22

CONTENTS

Programming the ENCO-M	23
Setting the Ua rotation rate.....	23
Setting the direction of rotation	23
Setting the totalizer reading	23
POWER SUPPLY	24
MAINTENANCE	25
Changing the battery	25
SPECIFICATIONS	26
Temperature ranges	26
Inputs and outputs	26
Sensor input	26
HF output	26
Alarm output	27
Vo or RS-485 data interface	27
Temperature input: (hardware and software options)	28
ANNEX	29
Matrix for the ENCO / Terz-94	29
Keyboard layout of the ENCO	30
Examples of connection	31
Standard version	31
Version with a current output.....	32

Functional description

Application

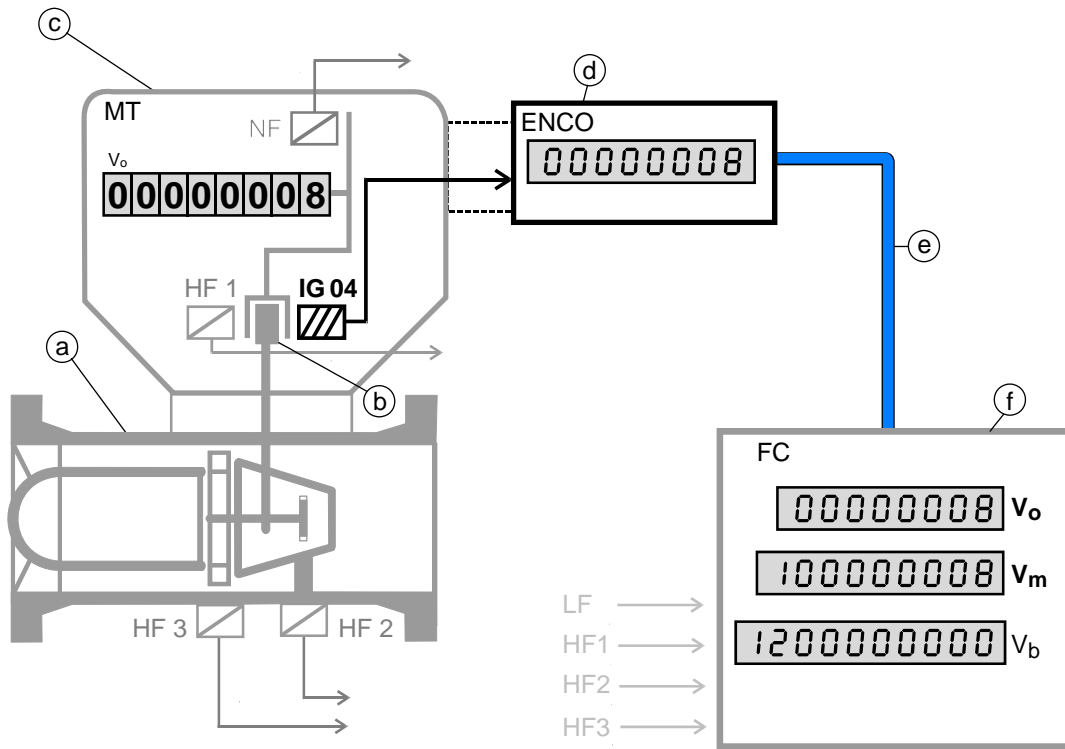

- (a) Gas meter
- (b) Magnetic coupling
- (c) MT - mechanical totalizer
- (d) ENCO - transmitter unit for totalizer readings

- (e) Data transfer line
- (f) FC - flow computer

- V_o Volumetric totalizer - meter
- V_m Volumetric totalizer
- V_b Volumetric totalizer, corrected

- ▧ LF, HF1, HF2, HF3 pulse generators
1 channel, [Namur, Reed]
- ▨ IG 04 rotary direction transmitter
2 channels with
flow / reverse flow, [Wiegand]

Method of operation

The direction of rotation is detected by the IG04 pulse system and shown in the display. Thanks to a specific logic of the electronics, the pulses are monitored by 100%.

In the main totalizer, the totalizer reading is shown exactly on the basis of defined and calibrated parameters (factor, divisor, number of decimal places).

On the display of the flow rate, you can read the gas volume which has flowed through the gas meter per time unit (this is determined by the pulse value of the gas meter).

At the HF output, the unchanged signal frequency of the input pulses is outputted.

Schematic sketch of the ENCO - F

integrated in the case or mounted on the case as a separate unit

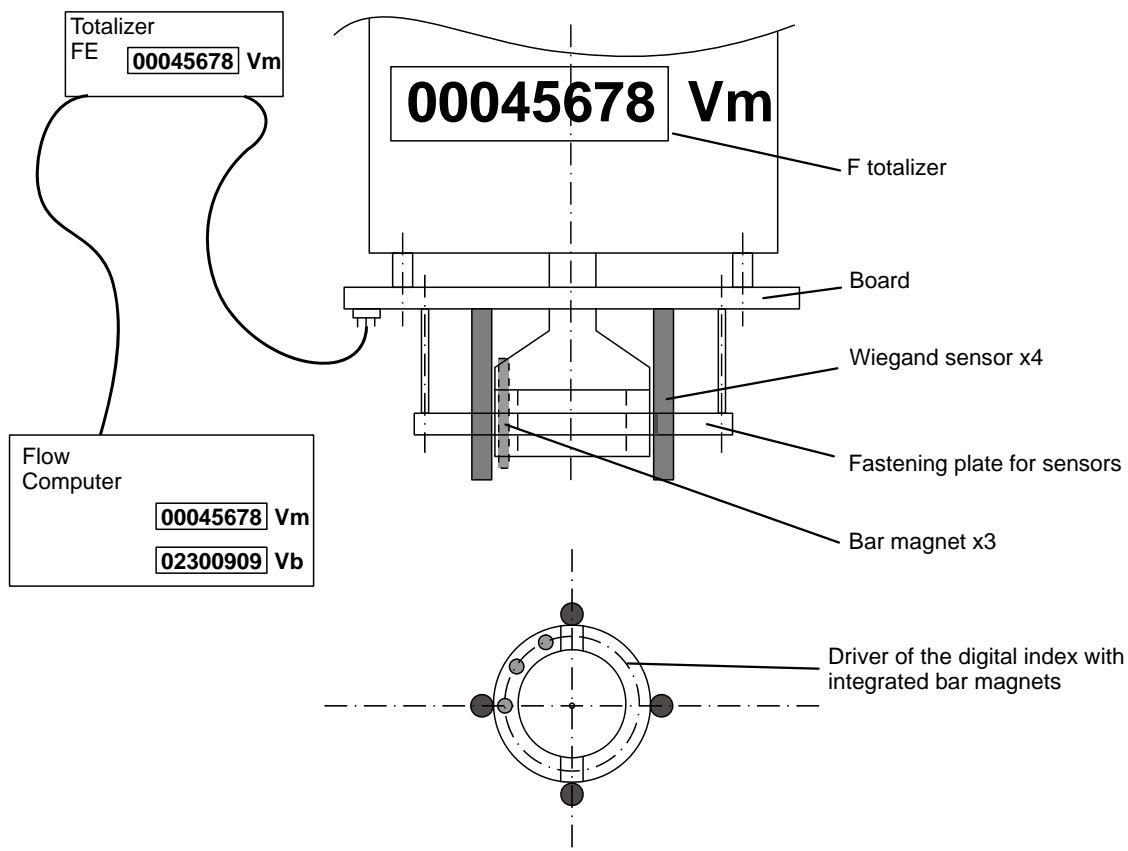

FUNCTIONAL DESCRIPTION

Schematic sketch of the ENCO - M

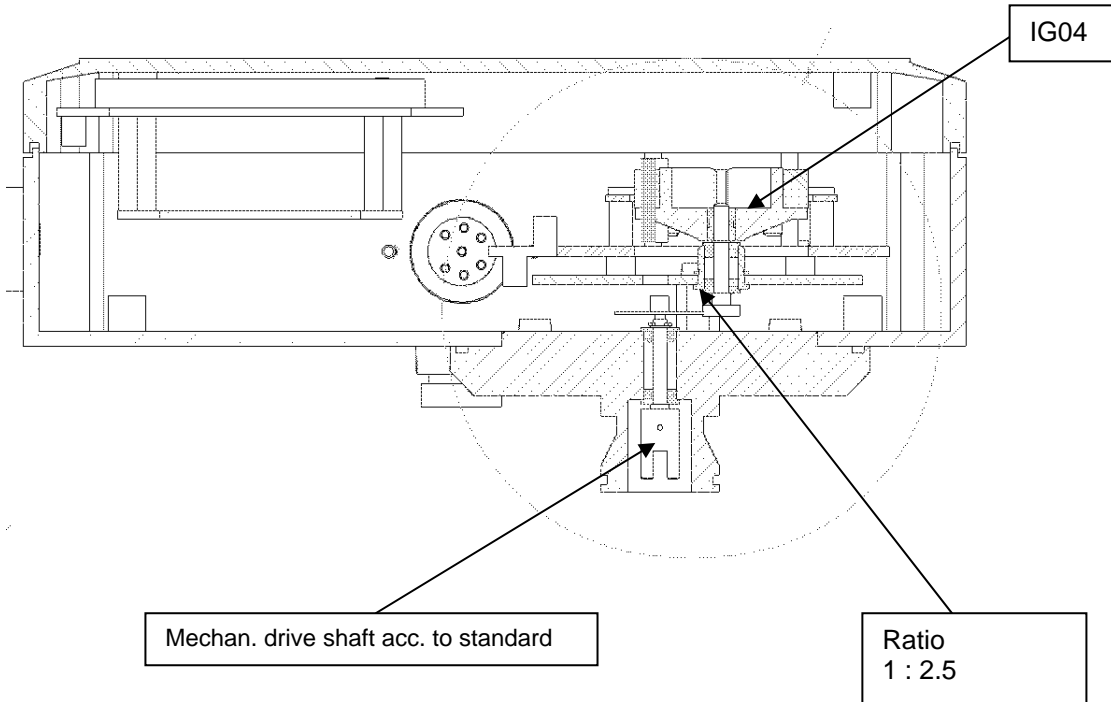

Block diagram for the ENCO - F/M

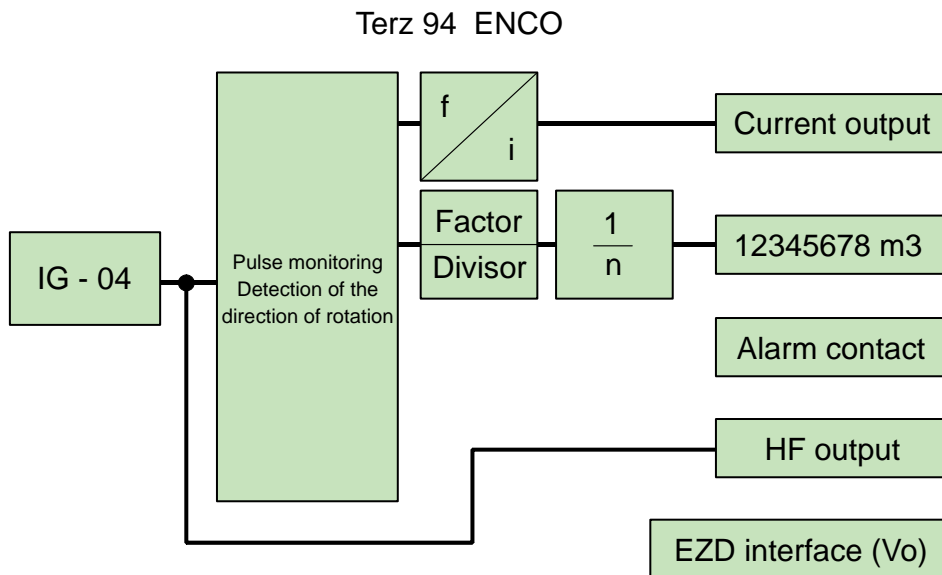

The digital data are outputted via the "Vo data interface" X15 output.

Safety instructions

The ENCO transmitter unit is used to measure the volume at measurement conditions using the volume pulses from gas meters and to digitally transmit totalizer readings to gas volume correctors.

The ENCO complies with the currently applicable standards and regulations. However, failure to operate it properly may cause hazards.

Persons who install or operate the ENCO transmitter unit in areas subject to explosion hazards, must be familiar with the currently applicable explosion protection standards and regulations.

It is essential that the operating instructions for the installer are followed! (See annex.)

The electronic totalizing system of the explosion-protected version has been approved for use in areas subject to explosion hazards and its code is: II 2 G EEx ib[ia] IIC T4 or T3

The appropriate certificate of conformity can be found in the annex and its reference number is: TÜV 02 ATEX 1970

Please follow the following instructions:



Danger of explosion

In the manual, this symbol warns you of an explosion hazard. Please follow the instructions given next to this symbol. As to the danger of explosion, please note the following in particular:

- Only the explosion-protected design of the ENCO may be used in areas subject to explosion hazards.
- The battery must be changed in an area without explosion hazards.
- When the ENCO is used in areas subject to explosion hazards, it is permissible to use only an isolating device to connect it to the gas volume corrector.

The ENCO has been approved for use in the ambient temperature range from -20°C to +60°C only.

No warranty claims can be asserted if there is unauthorized interference with the device!

Installation

Electrical connections

To reach the electrical connections, first remove the cover of the meter head.

Terminal board

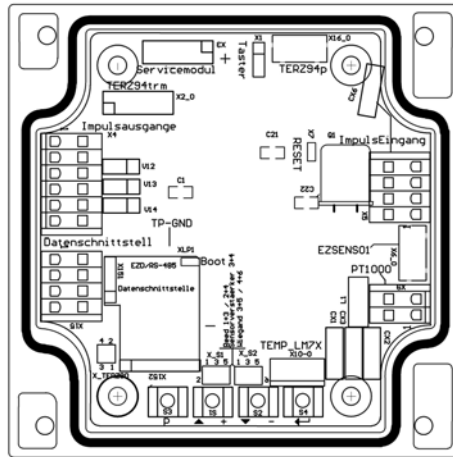

The digital data line is to be connected via the X15 terminal block.



In areas subject to explosion hazards, the ENCO must be connected only to certified intrinsically safe circuits.

Terminal diagram for the ERZ 9000 T

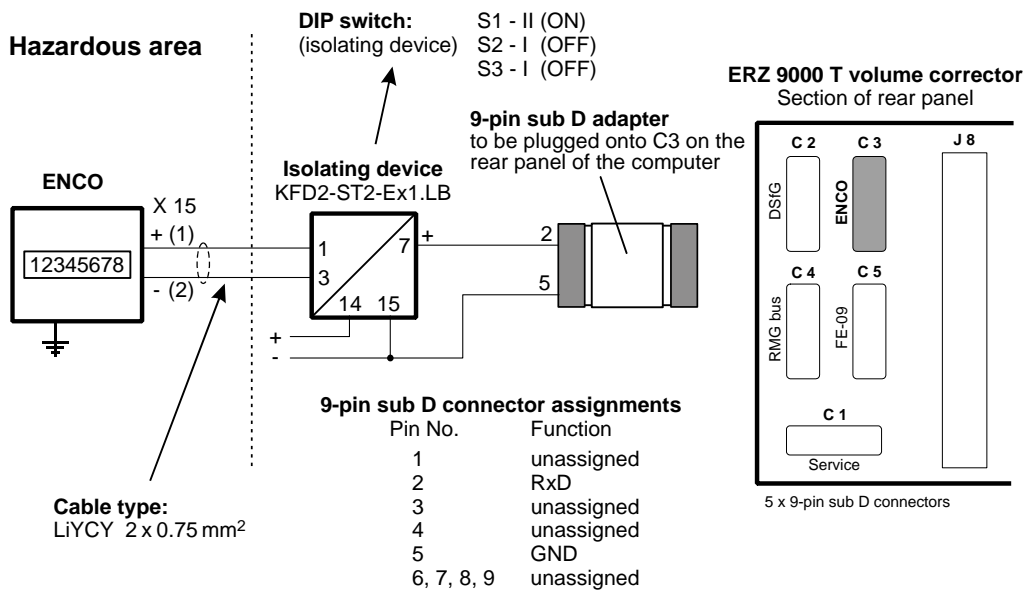

Terminal diagram for the EC 994

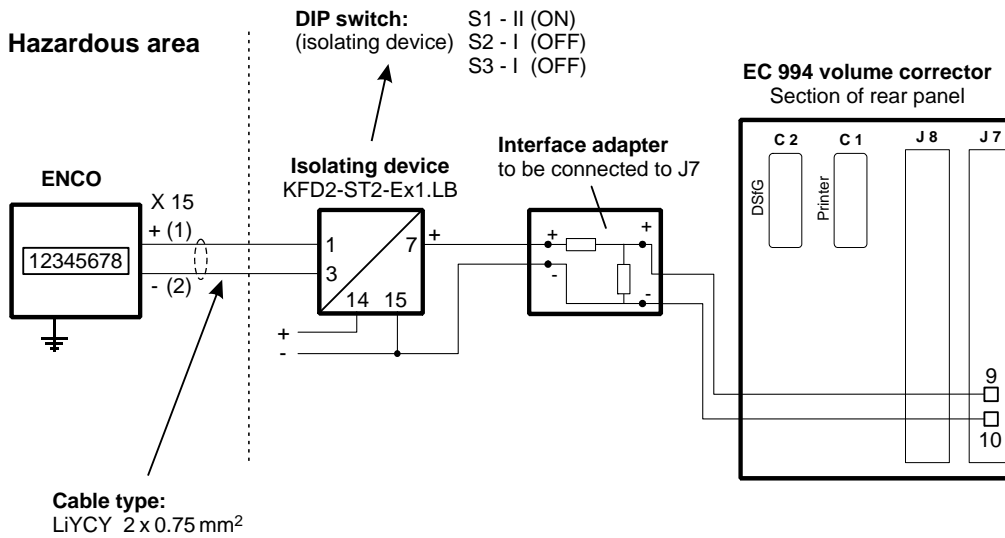

Terminal diagram for the ERZ 2200

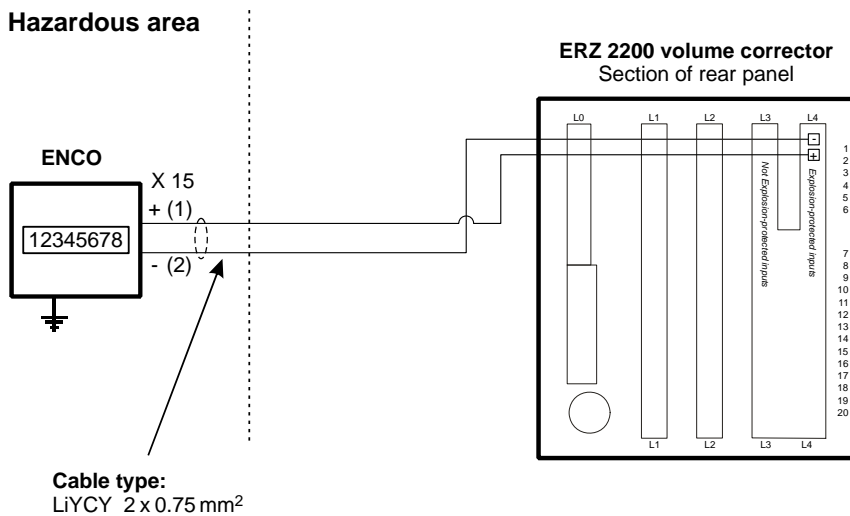

The transmitter unit can only be connected to the gas volume corrector if the corrector card is fitted with an isolating device!

INSTALLATION

Terminal diagram for the ERZ 2000

Volume corrector **with** integrated isolating device

Hazardous area

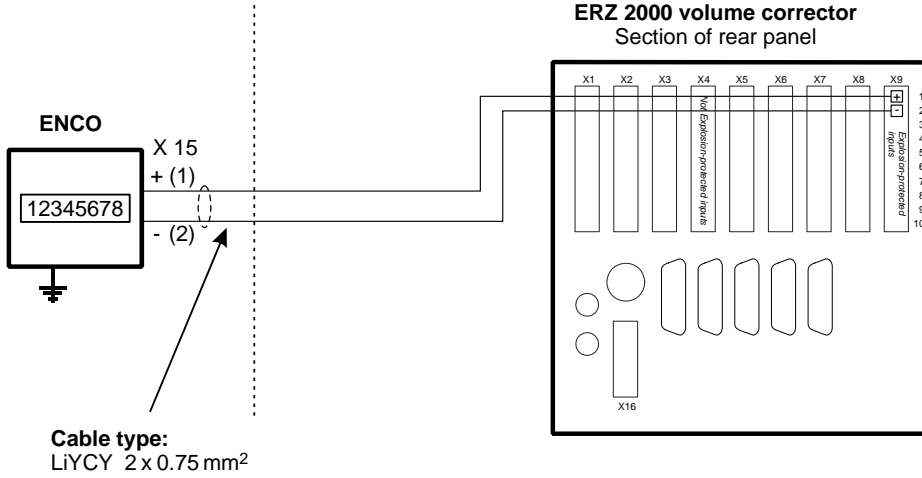

The transmitter unit can only be connected to the gas volume corrector if the corrector is fitted with an isolating device!

Terminal diagram for the ERZ 2000

Volume corrector **without** integrated isolating device

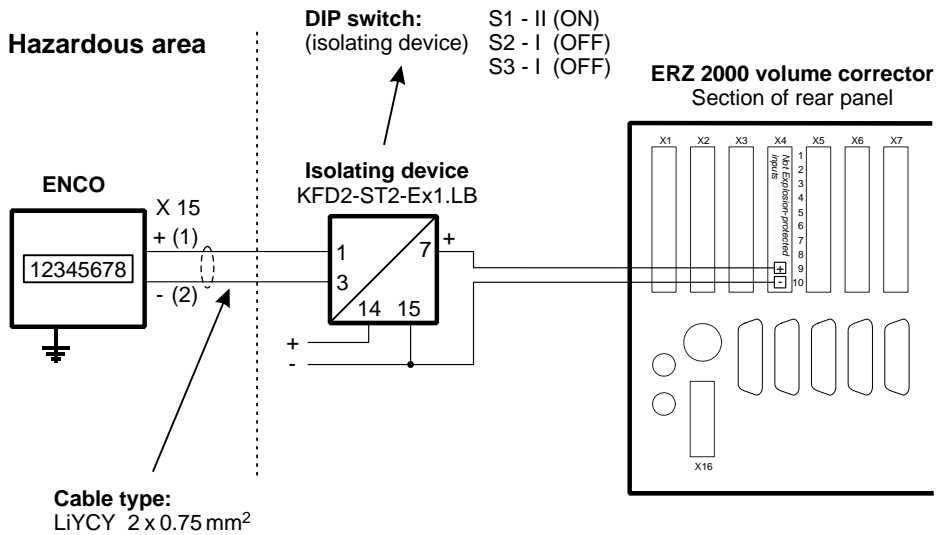

Connectors

7-pin plastic connector
(Binder / series 693)

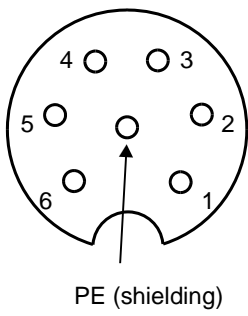

- 1 -
- 4 + unassigned

- 2 -
- 5 + alarm

- 3 -
- 6 + HF signal Namur
(only with ENCO-F)

6-pin metal connector
(Binder / series 423)

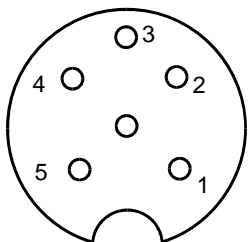

- 1 -
- 4 + EZD protocol

- 2 -
- 5 + unassigned

- 3 -
- 6 + unassigned

Cable gland

In the case of devices which are supplied by an additionally integrated current board, there is a cable gland for the power supply cable on the rear side of the device. Clamp the shielding **on both sides**, as shown in the picture below, into the high-strength cable gland located on the outside of the case:

- Unscrew the cap nut.
- Pull out the plastic clamping piece.
- Push the cable end through the cap nut and the clamping piece and bend the shielding backwards.
- Put the clamping piece back into the connecting piece.
- Screw on the cap nut again.

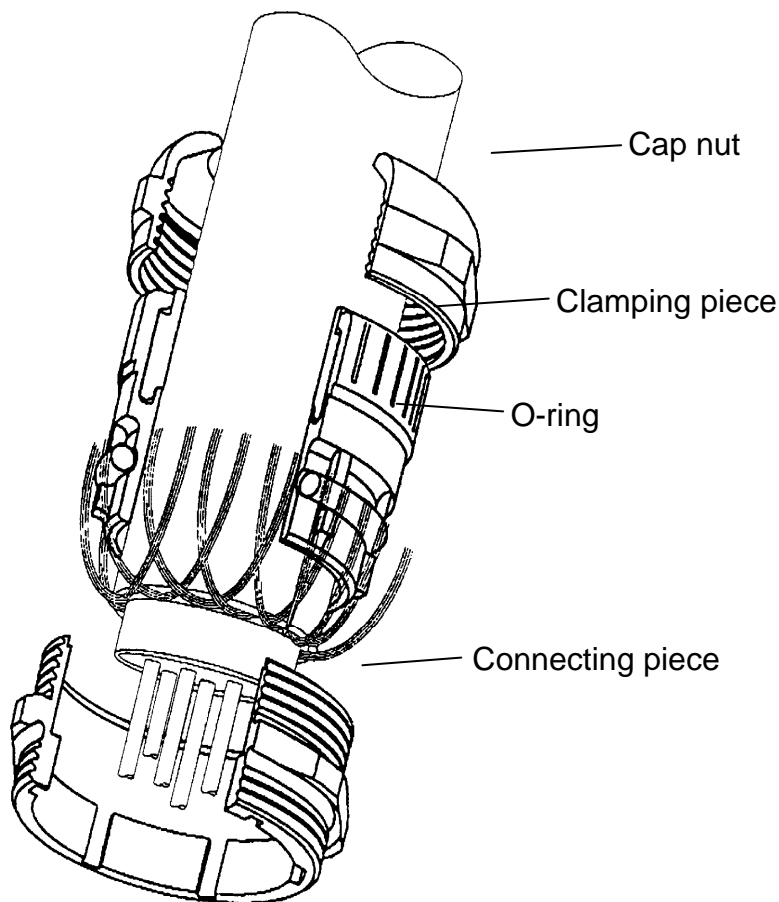

Start-up

Initializing the device

Setting the totalizer reading

Set the totalizer to the desired reading. To do this, access coordinate A00 and input the desired value (see "Programming" on page 14). Set the remaining parameters in the same way.

NOTE:

All parameters can only be changed if the device has been opened.

Check the parameter settings, in particular the factor (Z02), divisor (Z03) and meter factor (A06). Parameterization is different for the ENCO-F and the ENCO-M.

Parameterizing the ENCO-F:

In order to correctly show the totalizer reading, the "Factor" (Z02) and "Divisor" (Z03) parameters are decisive. If the ENCO-F is supplied fitted onto the meter head of the gas meter or parameterized for a gas meter, these parameters must not be changed. If you intend to retrofit a non-parameterized device, contact RMG and indicate the manufacturer number of the gas meter and ask for these two values.

The meter factor (pulse value, A06) is required to calculate the flow rate (A02), frequency (Z06) and output current (C01) and can be seen from the test certificate of the gas meter.

When operating the device with a current output:
Also check the settings of the current output.

Parameterizing the ENCO-M:

The "Factor" (Z02) and "Divisor" (Z03) parameters must always be set at 1; the Ua rotation rate is to be set indirectly via the "Decimal places" (Z01) parameter.

START-UP

Table 1: Ua rotation rates for RMG turbine meters

Ua rotation rate	Z01 (number of decimal places)
0.1	2
1	1
10	0
100	0

Afterwards you still have to check and/or set the direction of rotation (Z04):

- 0: Clockwise rotation (if you look at the mechanical drive shaft of the gas meter). This is the standard setting which is valid for all RMG gas meters.
- 1: Counterclockwise rotation.

Parameterizing the gas volume corrector

On the gas volume corrector, you have to set the interface parameters. These are listed here as an example for RMG's ERZ 9000 T flow computer series and the EC 994 (the relevant coordinates are indicated):

Mode 1:	ON	(S18)	Baud rate:	2400	(S20)
Mode 2:	EZD-R	(S19)	Stop bits:	1	(S21)
			Parity:	Even	(S22)

Afterwards you still have to change the operating mode for volume measurement (J18). In the case of RMG gas volume correctors, this is one of the "EZD" operating modes.

Connecting the gas flow

To do this, follow the operating instructions of the gas meter! The following instructions apply to RMG turbine meters:



Do not fill any downstream pipelines or station sections through the turbine meter. This may speed up the turbine wheel and lead to excessively high flow rates with resultant damage.

Short-time overload operation of 20% above the maximum flow rate Q_{\max} is permissible. No damage will occur in the case of a return flow without shocks.

Operation

Display

In normal operating mode, the main totalizer is displayed.

If you press the external control button, you can select the other display values. After an adjustable time has elapsed, the ENCO will return to displaying the main totalizer.

If the ENCO displays nothing, it is in energy-saving mode. In this mode, the display is switched off completely. However, incoming pulses are processed and the outputs are set. As soon as you press the control button, the display values will appear again.

Display
switched off:

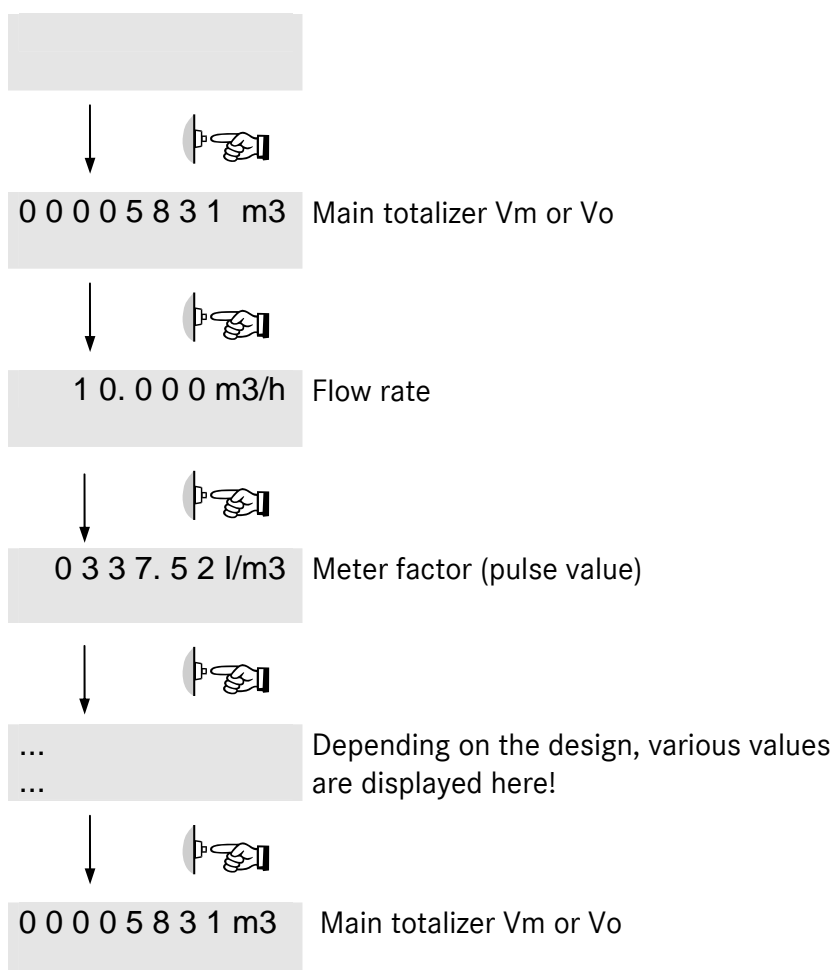

For a complete list of display values, please see the annex.

OPERATION

NOTE:

The button located externally on the case reacts when it is released and not when it is pressed. The duration of pressing the button is evaluated and results in different reactions of the device. Pressing the button for a short time causes the display to show the next display value, while pressing the button for a longer time (more than 2 seconds) will activate all segments of the display (segment test) and then the display will switch over to showing the Vm totalizer. The following text describes procedures where the button is normally pressed for a short time.

Pointer designations

- 1 ENCO is running
- 4 Supply via the EZD interface / current module
- 5 Battery-powered mode

Programming

For programming the ENCO, use the four buttons on the bottom of the display board. Alternatively, you can program the device with the programming module (available as an accessory). The programming module is to be connected via a pin connector (see the picture below).

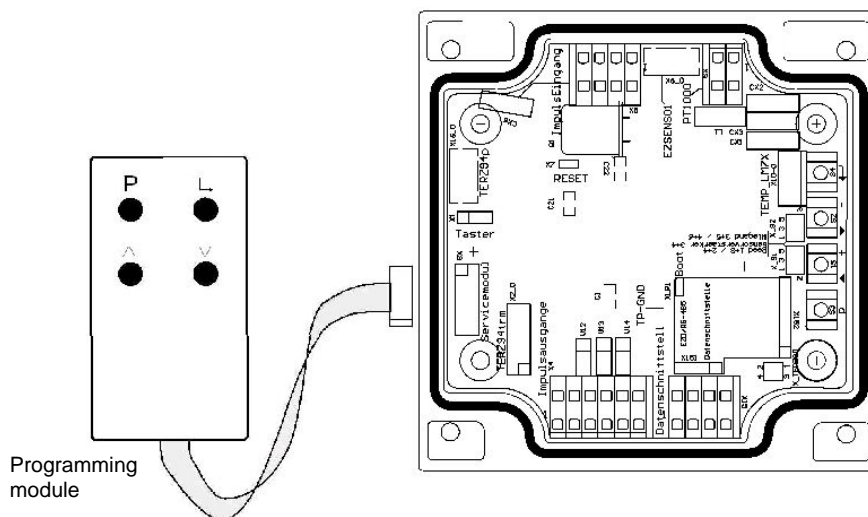

Programming with the programming module is to be performed in the same way as with the internal buttons.

The external and internal buttons correspond to each other in the following way:

Int. button	Ext. button	Meaning
P	P	Display mode: Switches over to programming mode (Press the button longer than 2 seconds.) Programming mode: Sets the decimal point at the current position.
+	▢	In display mode: Switches over to the next higher display value. In programming mode: - Increases the decimal place by 1. - Scrolls in the list. (Display value is identified by "L".)
-	▢	In display mode: Switches over to the next lower display value. In programming mode: - Decreases the decimal place by 1. - Scrolls in the list. (Display value is identified by "L".)
↔	↔	In display mode: Short-term view of the coordinate (e.g. A01) In programming mode: Moves to the right by one decimal place. (If the last decimal place has been reached: Quits programming mode.)

Principle of programming

You can program only the display values which can be accessed for writing or reading (RW). See the annex!

When you do your programming, always proceed as follows:

- First change over to the display value to be modified.
 - To do this, press either the control button (only forwards)
 - or the internal buttons "+" and "-" or the external buttons "∧" and "∨" (forwards and backwards).
- Change over to programming mode by pressing "P" for at least **2 seconds**. On the left side of the display, a flashing character or cursor will appear:

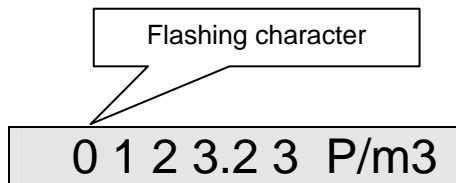

- Now you can modify the flashing decimal place by pressing either "+" or "∧" (+1) or "-" or "∨" (-1).

Example: If you press the "∧" button three times, the first decimal place will be increased from 0 to 3. If an "L" appears on the far left side of the display, the relevant value is a list. With a list, you can scroll only in the given values.
- After you have completed your programming of the first decimal place, press "↵" once and the next character will start to flash.

Now proceed with your programming until you have reached the last decimal place.
- Then you must operate "↵" once again to have the set value accepted and quit programming mode.
- Operate the "P" button to set the decimal point behind the flashing digit.

With totalizers, modes and integers, no decimal point is permitted.
- Press the control button if you have made an error or if you want to terminate data input.

Display values

Measured values, such as flow rate, temperature, frequency, etc. are display values and cannot be directly modified. However, there are many parameters which influence the formation of these measured values. These parameters are described in the following section.

Examples of display values:

Flow rate
Version number
Year of construction
Serial number
Value of the current output in mA
etc.

Displaying faults and events

In the ENCO, there are 16 fault messages or fault numbers (incl. spares) at the moment. Fault numbers are displayed in rolling mode, i.e. if there is more than one fault active, the display switches over to the next active fault at 1-second intervals (1 ... 16 ... 1 ... 16 ...).

"0" means fault-free operation.

Fault No.	Fault message
0	No fault
1	Wrong EEPROM version, invalid constants
2	Pulse fault (sensor failure)
3	Spare
4	Spare
5	Current output min/max
6	ADC - temperature
7	Temperature limit
8	LF pulse output
9	Spare
10	Spare
11	Spare
12	Spare
13	Spare
14	Spare
15	ENCO failure of 1 sensor
16	ENCO failure of 2 sensors

Parameters and modes of the ENCO

The following sections describe the meaning of the individual parameters.

Meter factor (pulse value, A06)

With the meter factor (pulse value), the relevant volumetric flow rate at measurement conditions is calculated from the signal frequency of the sensor element in the associated electronic totalizing system:

$$Q_m = \frac{f}{K} \cdot 3600 \left[\frac{\text{m}^3}{\text{h}} \right]$$

f: Signal frequency (Hz)

K: Meter factor (pulses/m³)

Q_m: Volumetric flow rate at measurement conditions (m³/h)

The meter factor has been calibrated in the factory in such a way that working cubic metres are directly displayed.

Any modification of this adjustment is within the operator's sphere of responsibility.

NOTE!

The new value is immediately used for all calculations performed after each modification of the meter factor.

The uninfluenced signal frequency of the sensor element is available at the HF output. The frequency range can be determined from the meter factor K and the minimum and maximum volumetric flow rates at measurement conditions of the gas meter in accordance with the following formulae:

$$f_{\min} = \frac{Q_{m\min}}{3600} \cdot K \quad f_{\max} = \frac{Q_{m\max}}{3600} \cdot K$$

Q_{mmin}: Minimum volumetric flow rate at measurement conditions

Q_{mmax}: Maximum volumetric flow rate at measurement conditions

K: Meter factor (pulse value)

Example:

$$Q_{m\min} = 16 \text{ m}^3/\text{h} \quad Q_{m\max} = 250 \text{ m}^3/\text{h} \quad K = 2362 \text{ pulses}/\text{m}^3$$

$$f_{\min} = \frac{16}{3600} \cdot 2362 \text{ Hz} = 10.5 \text{ Hz} \quad f_{\max} = \frac{250}{3600} \cdot 2326 \text{ Hz} = 164 \text{ Hz}$$

Configuration (A09)

The basic configuration of the ENCO is implemented via an 8-character display value. This "mode" defines the operating mode of the device.

Some parameters require a specific hardware or hardware configuration.

NOTE!

Hardware and software configurations must coincide.

Any modifications of these parameters can cause malfunctions.

Let's start on the left side of the display:

- **Internal parameters**

For testing and diagnostic purposes.

- **Mode of the main totalizer**

This parameter defines the performance of the main totalizer if a fault occurs.

0: Main totalizer will be stopped if a fault occurs.

1: Main totalizer continues to run if a fault occurs.

- **Width of the LF pulse** (the ENCO has no LF output)

The LF pulse width can be set at 125 ms or 250 ms.

0: 125 ms

1: 250 ms

- **Cut-off time of the display**

A few minutes after you have operated the device for the last time, the display will switch off to extend the service life of ENCO's battery. There are the following times for selection:

0: 1 minute

1: 5 minutes

2: 10 minutes

3: 15 minutes

- **Interface protocol**

0: OFF

1: EZD 0 - standard

2: EZD 1 - Vo protocol

3: Test protocol

OPERATION

– **Temperature measurement**

- 0: OFF
- 1: PT1000 active

– **Current output**

(only possible with an appropriate hardware configuration)

- 0: OFF
- 1: Active current output
- 2: Active current output and signalling of faults

– **Operating modes**

There are the following operating modes at the moment:

- 0: TERZ – ENCO / F
- 1: TERZ – ENCO / M
- 2: TERZ – 1 channel
- 3: TERZ – 1 channel with start-stop totalizer
- 4: TERZ – 1 channel with reset totalizer
- 5: TERZ – 2 channels (without pulse monitoring)
- 6: TERZ – 2 channels (with x:y pulse monitoring)

Example:

00012000 MOD

- 0: TERZ-ENCO / F
- 0: Current output is switched off
- 0: No temperature measurement
- 2: EZD 1 protocol is active
- 1: Display cut-off time: 5 minutes
- 0: LF pulse width: 125 ms
- 0: Main totalizer will be stopped if a fault occurs.
- 0: No test or diagnostics mode is activated

Pulse monitoring

The ENCO has a pulse monitoring feature. The failure of a sensor has no impact on pulse counting but initiates a fault message.

Detection of the direction of rotation

Thanks to the IG04 pulse system and an appropriate logic, the direction of rotation is detected and taken into account when calculating the totalizer.

Flow rate at 4 mA

With this parameter, you set the flow rate (in m³/h) which corresponds to an outputted current of 4 mA. Generally, the minimum flow rate Q_{min} of the gas meter is set here. (This setting is made in the factory.)

Flow rate at 20 mA

With this parameter, you set the flow rate (in m³/h) which corresponds to an outputted current of 20 mA. Generally, the maximum flow rate Q_{max} of the gas meter is set here. (This setting is made in the factory.) Then the current which will be outputted for flow rates within the programmed limits will be between 4 and 20 mA and results from linear conversion.

Current default value (calibration current)

With this parameter, you set the value of the calibration current. A constant calibration current is outputted if the current output mode parameter is set to default. The value of the calibration current must be within the following limits:

Minimum value: 4 mA
Maximum value: 20 mA

Current output mode

Here you define the measured or default value which is to be outputted.

- 0: Constantly 4 mA
- 1: Constantly 20 mA
- 2: Default value (see above)
- 3: Flow rate Q_m

All other values are not permitted!

Current damping

Here you define how the current output is to be damped.
Permissible values for D are 0 to 0.9!

Output current = (1-D) x value + D x old value

Correction factors for current offset and current rise

The current output is adjusted in the factory through two correction factors (offset and rise).

In the event that a readjustment should really be necessary, there is a PC-based program available which will define the new offset and rise values for you.

Parameters for the ENCO

In the Terz-ENCO operating mode, there are three additional values to be inputted:

Factor, divisor and number of decimal places (exponents 0, 1, 2).

These parameters are determined when the device is calibrated (in the factory) and must not be changed!

Programming the ENCO-M

As to the ENCO-M, there are five coordinates (Z01, Z02, Z03, Z04 and A00) to be programmed by the user.

Setting the Ua rotation rate

1. Set **Z01** (number of decimal places DP, see the digital index of the gas meter).
2. Set **Z02** and **Z03** in accordance with table 1 below.

Values to be set for "Factor (Z02)" and "Divisor (Z03)" in accordance with the "Decimal places (Z01)" and the Ua rotation rate (see type plate on the mechanical drive shaft):

Totalizer TOT	Decimal places DP	Ua rotation rate (m ³ per rotation)			
		0.1	1	10	100
Digital index	Z01	Z02 / Z03	Z02 / Z03	Z02 / Z03	Z02 / Z03
1234576. 78	2	1 / 1	10 / 1	100 / 1	1000 / 1
1234567. 8	1	1 / 10	1 / 1	10 / 1	100 / 1
12345678	0	1 / 100	1 / 10	1 / 1	10 / 1
12345678 _{x10}	0	1 / 1000	1 / 100	1 / 10	1 / 1

Values printed in bold typeface = standard settings

Setting the direction of rotation

Access **Z04** (direction of rotation) and set or confirm value 0 (= clockwise) or value 1 (= counterclockwise).

Setting the totalizer reading

Access **A00** (Vo totalizer) and set or confirm the desired value.

Power supply

Depending on the configuration of the device, there are different options of power supply.

1. The basic ENCO model is supplied by an internal lithium battery which allows the device to be operated continuously for a period of six years. The marginal conditions are as follows: The device is read once a week or "woken up" by pressing the external button.
2. If the ENCO uses an externally supplied interface module for transmitting data, the service life will extend from six years to more than 10 years.
3. The ENCO-S (current transmitter) can be supplied completely through a current loop. To ensure over a period of six years that pulses are processed even if there is a power failure of the current loop, it is essential that the battery of the basic device (available as an option) is installed.

Maintenance

Changing the battery

For the main battery, use only lithium batteries from Sonnenschein of type SL 770/P, size C, 3.6 V or from Saft of type LS 33600 of the special design with isolated connecting wires and plug-in contacts.

These batteries have a service life of a minimum of 6 years and can be ordered ready for installation from RMG under the following order number:

For Non-Ex (not explosion-protected) devices: 86.90.613.00
For Ex (explosion-protected) devices: 86.90.614.00

- If you use other batteries than the replacement batteries from RMG, the approval of the device for use in areas subject to explosion hazards will expire and it will no longer be permissible to use the ENCO in such areas.
- In areas subject to explosion hazards, you must never insert or remove the battery. Remove the display board from the case and change the battery in an area without explosion hazards.

To change the battery, you must proceed as follows:

- If you open the cover of the totalizer on the rear side, you can see the battery which is attached with a cable tie.
- If the gas meter is located in an area subject to explosion hazards, remove the connector with the wires to the control button, disconnect all cable connections (see chapter "Electrical connections" – Remember the terminals and colours!) and take the display board to an area without explosion hazards.
- Remove the connecting wires of the battery from the contacts on the bottom of the terminal board.
- Loosen the four fastening screws of the battery retaining board, remove the cable tie with which the battery is attached and remove the battery.
- Attach the new battery with the cable tie enclosed.
- Plug the connecting wires of the battery on the contacts of the terminal board. Observe the marking of the polarity.
- Fasten the battery retaining board again using the four screws.
- If you have previously disconnected the wires from the sensor and the control button, connect them again (make sure that the polarity of the sensor wires is correct!).
- Close the case.

Specifications

Temperature ranges

Type: ENCO I12 G EEx ib IIC T4 from -20°C to +40°C
 I12 G EEx ib IIC T3 from -20°C to +60°C

In the case of special designs, even higher or lower fluid temperatures are possible.

Inputs and outputs

Sensor input

Terminals:	X6	
	X5	open
	X_Terz90	open
Type of sensor:		
IG-04	X_S1	no jumpers
	X_S2	no jumpers

External sensors (X5) are not permissible!

HF output

In the case of the explosion-protected (Ex) design, the device can only be connected to a certified intrinsically safe circuit. (For Ex connected loads, see the approval certificate.)

Terminals:	X4,4 (+)
	X4,3 (-)
Output:	Open-drain transistor
T _{pulse} :	1 ms ± 10%
f _{max} :	300 Hz

	Explosion-protected	Not explosion-protected
U _{min} :	2.0 V	2.0 V
U _{max} :	28 V	30 V
I _{max} :	60 mA	400 mA
External inductance	1 H	
External capacitance	25 µF	

Alarm output

In the case of the explosion-protected (Ex) design, the device can only be connected to a certified intrinsically safe circuit. (For Ex connected loads, see the approval certificate.)

Terminals: X4,6 (+)
X4,5 (-)
Output: Open-drain transistor

	Explosion-protected	Not explosion-protected
U_{\min} :	2.0 V	2.0 V
U_{\max} :	28 V	30 V
I_{\max} :	60 mA	400 mA
External inductance	1 H	
External capacitance	25 μ F	

Vo or RS-485 data interface

In the case of the explosion-protected (Ex) design, the device can only be connected to a certified intrinsically safe circuit. (For Ex connected loads, see the approval certificate.)

Vo data interface: *internal* *Connector (Binder)*

Terminals: X15,1 (+) 4
X15,2 (-) 1
X15,3 and X15,4 open

U_{\min} : 7.0 V
 U_{\max} : 13.5 V
 I_{\max} : 15 mA
 P_{\max} : 210 mW

Isolating device: KFD2-ST2-Ex1.LB (Pepperl+Fuchs)

Note: If the EZD protocol or the RS-485 bus is used, the device is supplied via the data interface.

RS-485 data interface:

Terminals: X15,1 (+ supply)
X15,2 (- supply)
X15,3 (line A)
X15,4 (line B)

U_{\min} : 7.0 V
 U_{\max} : 10.5 V
 I_{\max} : 428 mA
 P_{\max} : 900 mW

Isolating device: 17-21S1-S111 / EExi (Bartec)

SPECIFICATIONS

Temperature input: (hardware and software options)

For Ex connected loads, see the approval certificate.

Terminals:	X9,2 (+) X9,1 (-)
Type of sensor:	PT 1000
Measuring range:	-20°C to 60°C
Resolution:	± 0.2°C

Annex

Matrix for the ENCO / Terz-94

Coordinate	Description	Enco-F	Enco-M	Terz94 1 channel	Terz94 2 channels	Terz94-S 1 channel	Terz94-S 2 channels						
A00	Vo / Vm totalizer	X	X	X	X	X	X						
A02	Flow rate	X	NO	X	X	X	X						
A03	Totalizer for disturbing quantities	NO	NO	NO	X	NO	X						
A04	Start-stop totalizer	NO	NO	X	NO	X	NO						
A05	Resettable totalizer	NO	NO	X	NO	X	NO						
A06	Meter factor (pulse value)	X	NO	X	X	X	X						
A07	Pulse scaler	NO	NO	X	X	X	X						
A08	LF decade scaler	NO	NO	X	X	X	X						
A09	Configuration	X	X	X	X	X	X						
A10	Error	X	X	X	X	X	X						
A11	Pulse comparator X from X:Y	NO	NO	NO	X	NO	X						
A12	Pulse comparator Y from X:Y	NO	NO	NO	X	NO	X						
B01	Software version number	X	X	X	X	X	X						
B02	Serial number	X	X	X	X	X	X						
B03	Year of construction	X	X	X	X	X	X						
C01	Output current	NO*	NO	NO	NO	X	X						
C02	Flow rate at 4 mA	NO*	NO	NO	NO	X	X						
C03	Flow rate at 20 mA	NO*	NO	NO	NO	X	X						
C04	Default value	NO*	NO	NO	NO	X	X						
C05	Current output mode	NO*	NO	NO	NO	X	X						
C06	Offset	NO*	NO	NO	NO	X	X						
C07	Rise	NO*	NO	NO	NO	X	X						
C08	Current damping	NO*	NO	NO	NO	X	X						
Z01	Number of decimal places	X	X	NO	NO	NO	NO						
Z02	Factor	X	X	NO	NO	NO	NO						
Z03	Divisor	X	X	NO	NO	NO	NO						
Z04	Enco's direction of rotation	X	X	NO	NO	NO	NO						
Z05	Test totalizer	X	X	NO	NO	NO	NO						
Z06	Frequency	X	NO	X	X	X	X						
Z07	Qm maximum value	0	0	0	0	0	0						
Z08	Frequency mode	0	0	0	0	0	0						
Z09	Error status	0	0	0	0	0	0						
<table border="1"> <tr> <td>NOT AVAILABLE</td> <td>NO</td> </tr> <tr> <td>AVAILABLE</td> <td>X</td> </tr> <tr> <td>AVAILABLE in service mode</td> <td>0</td> </tr> </table>		NOT AVAILABLE	NO	AVAILABLE	X	AVAILABLE in service mode	0	* possible as an option with another hardware configuration					
NOT AVAILABLE	NO												
AVAILABLE	X												
AVAILABLE in service mode	0												

Keyboard layout of the ENCO

ENCO Display mode

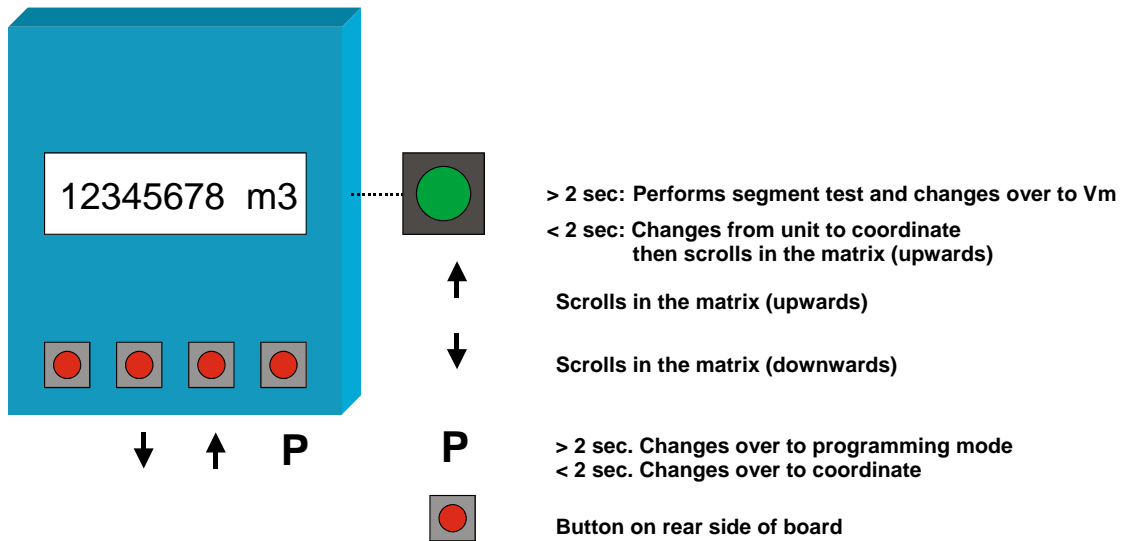

ENCO Programming mode

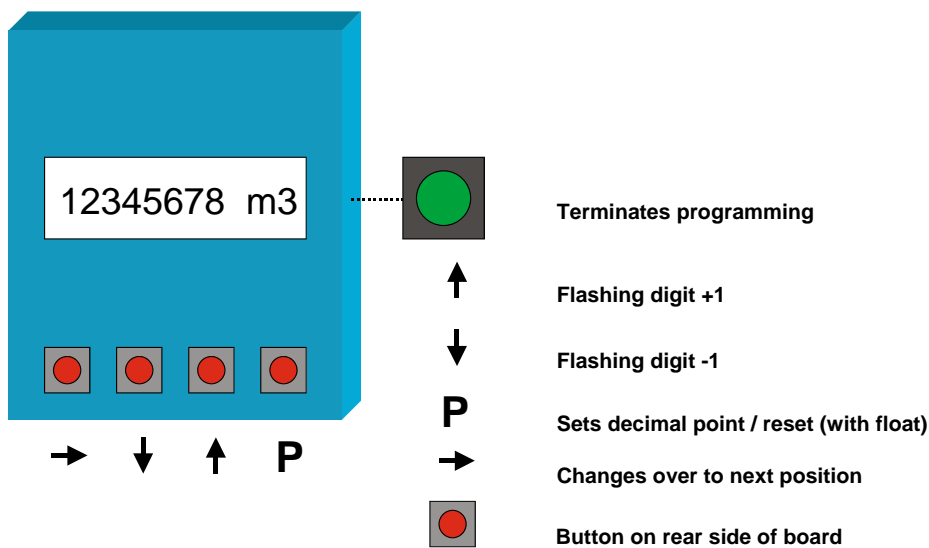

Examples of connection

Standard version

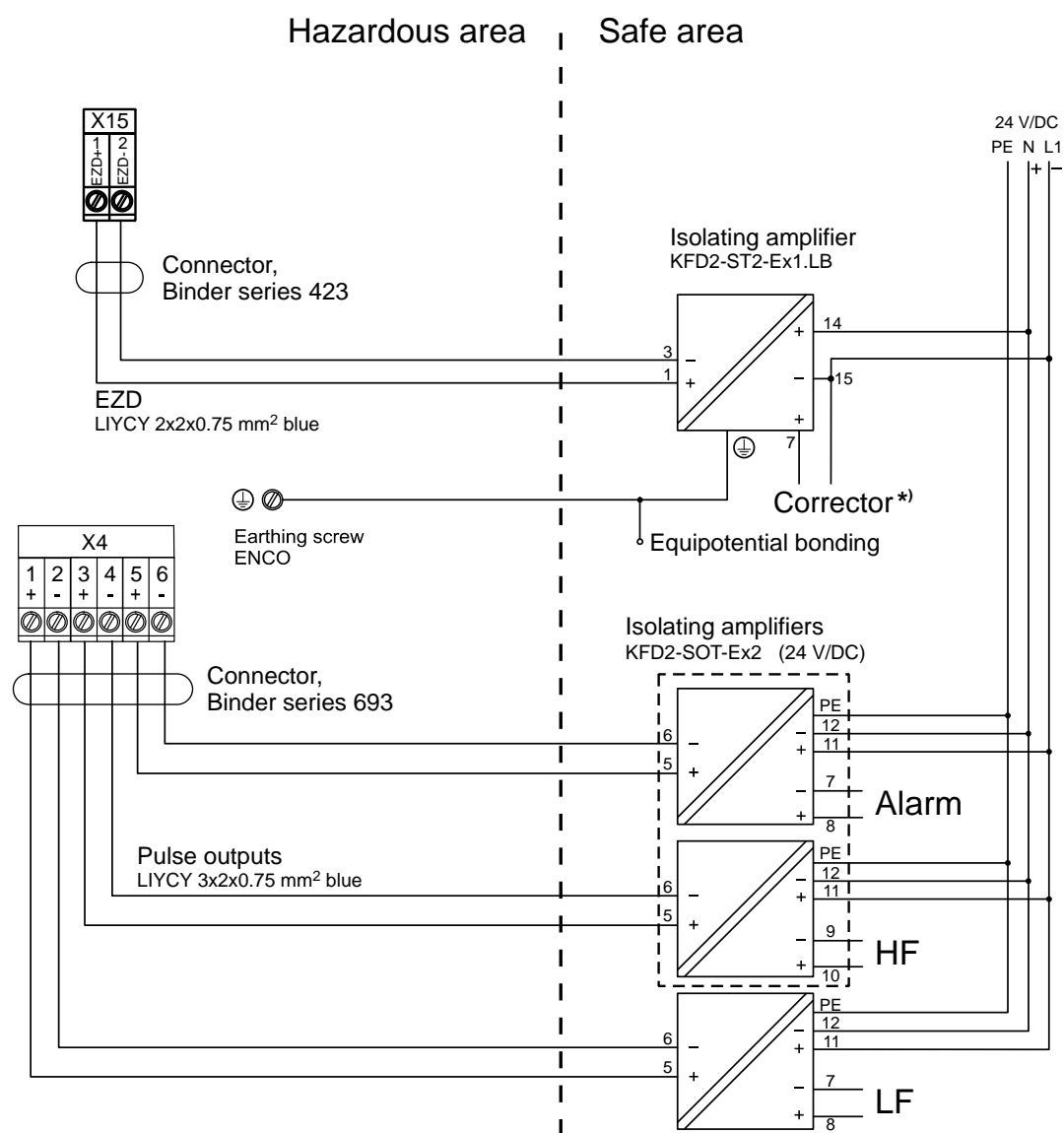

*₁) In the case of the ERZ 2200 gas volume corrector, the ENCO can be connected directly provided that the corrector card is fitted with an isolating module.

Version with a current output

(Connection only via a current module with built-in back-up battery)

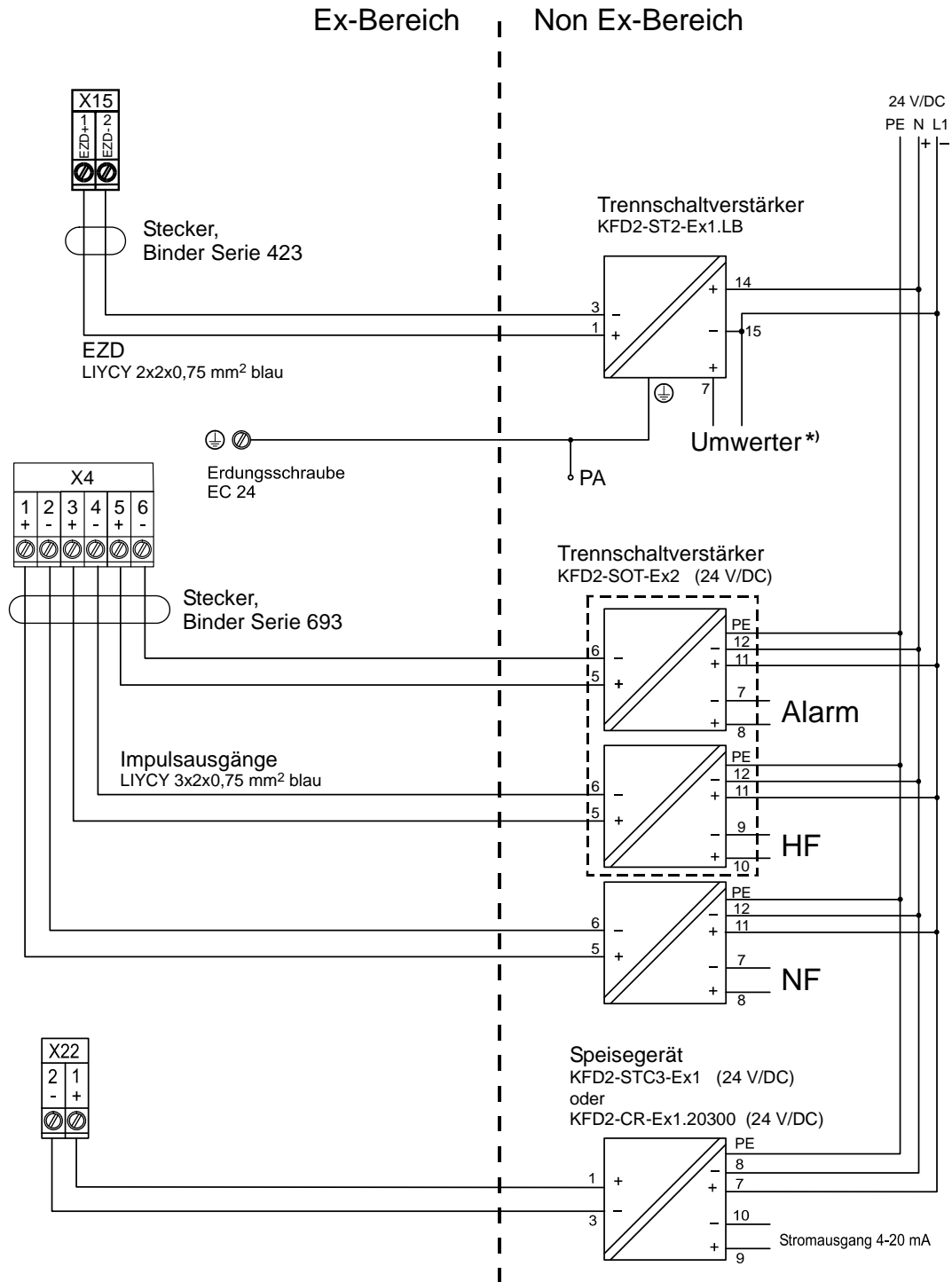

*₁) In the case of the ERZ 2200 gas volume corrector, the ENCO can be connected directly provided that the corrector card is fitted with an isolating module.