

Rotary Displacement Meter DKZ 04



OPERATING INSTRUCTIONS

**Serving the Gas
Industry Worldwide**

STATUS DECEMBER 2007



by Honeywell

Note:

Unfortunately, paperwork does not automatically update itself but technical developments are constantly being made. Therefore, we reserve the right to change the descriptions and statements contained in our operating instructions without prior notice. However, you can conveniently download the most recent version of this manual (and those of other devices) from our website www.rmg.com.

RMG Messtechnik GmbH

Otto-Hahn-Str. 5

35510 Butzbach (Germany)

Fax: +49 (0)6033 897-130

E-mail: RS-HPS-Messtechnik@Honeywell.com

Phone numbers:

Switchboard: +49 (0)6033 897-0

Customer Service: +49 (0)6033 897-127

Spare Parts: +49 (0)6033 897-173

INTENDED USE AND PERFORMANCE DATA	1
OPERATING PRINCIPLE.....	1
DUTY OF CARE BEFORE AND DURING OPERATION	2
PERMISSIBLE POSITIONS OF INSTALLATION.....	3
Notes on positions of installation	3
Tightening torques for flange screws:.....	3
IMPERMISSIBLE MODES OF OPERATION.....	4
TRANSPORT, STORAGE AND INSTALLATION.....	4
DEFINING THE DIRECTION OF FLOW	6
Adjusting the totalizer	7
COMMISSIONING OR START-UP	8
SERVICING AND MAINTENANCE.....	8
Maintenance schedule.....	9
Type: G 1000 and smaller	9
Type: G 1600 and larger	9
Lubricant change	10
Filling up oil	10
Draining oil	11
Quantities of lubricating oil required	11
Lubricant regulations.....	11
Servicing and troubleshooting table	12
Spare parts and accessories.....	12
REMOVING THE GAS METER	13
ACCESSORIES	13
Installable pulse generators for the CL 98 totalizer	13
Subsequent installation	14
Pulse generators for connection via a mechanical drive shaft	15
Mechanical drive shaft for the CL 98 totalizer.....	16
Installation description	17

CONTENTS

ROTARY DISPLACEMENT METERS – ITEMS	18
Notes on the use of threaded sleeves.....	18
Item No. Designation (see detailed overview on page 21).....	18
Rotary displacement meters – Detailed overview	19
RECYCLING AND DISPOSAL	20
INFORMATION PAGE.....	21

Intended use and performance data

RMG rotary displacement meters have been designed for the volumetric measurement of gases in pipelines.

RMG Messtechnik GmbH shall not be held liable for warranty or compensation for consequential loss or damage if the technical limits of use and/or the safety instructions are not complied with. The same shall apply for defects caused by the fact that the recommended inspections were performed too late or improperly.

Operating principle

The rotary displacement meter is a volumetric meter for measuring gas in pipelines. If there is a pressure loss in the section from the inlet to the outlet of the gas meter, this causes a rotational torque at the rotary pistons. When this torque exceeds the steady-state torque of the parts to be actuated, the rotary pistons start to rotate in the direction of the arrows. In the course of the rotational movement, the chambers forming between the rotary pistons and the case are filled and evacuated so that the rotation of the pistons represents a measure for the volume that has flowed through. A matching gearing is used to translate this rotational movement to a totalizer which continuously counts the gas volume in working cubic metres. A compact electronic volume corrector which is optionally available converts the gas volume measured into the gas volume at base conditions.

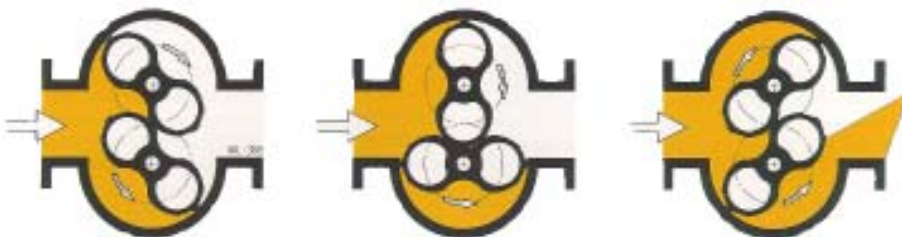

Duty of care before and during operation

First read these instructions carefully before you start to operate the gas meter!



CAUTION! Calls attention to all dangerous situations.

WARNING! Points to imminent risks of bodily injury.

Upon receipt or acceptance of the rotary displacement meter, it has to be checked for shipping damage and completeness by means of the delivery and order notes.

Make sure that you comply with occupational health and safety rules, safety instructions and the operating instructions. Read the **information page** prior to commissioning or start-up. Any instructions or changes stated there have to be carried out. The work described below is to be performed only by qualified staff who are familiar with the functions of the rotary displacement meter and its components and are conversant with the safety instructions to be followed. Responsibility for operation of the gas meters is to be stipulated and defined precisely so that there are no unclear competencies. This rotary displacement meter complies with European safety regulations. Nevertheless, there may be inevitable technical residual risks of personal injury and damage to property. To eliminate these residual risks, operating staff have to follow the **safety instructions** below:

- The measuring stations are to be designed in such a way that during operation, even in the case of faulty operation or possibly occurring disturbance, the rotary displacement meter is not subjected to sudden shock waves and the operating conditions do not exceed those of the permissible field of application. To avoid damage to the gas meter, it is essential to observe the speed limits.
 - Do not make any improper repairs or changes to the rotary displacement meter. In the case of trouble, please contact RMG's Customer Service.
 - Any unauthorized modifications or alterations of the gas meter or live parts are not permitted for safety and legal metrology reasons.
 - Do not remove any gas pipes unless they are depressurized and purged with neutral gas.
 - The operating staff must be competent and familiar with the equipment and must have been authorized and instructed to do such work!
 - The operating staff are obliged to report any changes occurred to the gas meter immediately to their superior.
 - The operator is obliged to make himself/herself familiar with the safety, control and monitoring elements by means of these operating instructions.
 - The gas meter is to be installed in good order and condition in accordance with its intended use, and its performance limits are not to be exceeded.
 - The gas temperature range must not exceed -10°C to $+40^{\circ}\text{C}$.
 - Remove any solid, liquid and powdery substances from the conveying area.
-

- When cleaning agents or sprays are used, there is a risk of poisoning by breathing in the substances or of chemical burns by touching them.
- Make sure that clean conditions prevail at the installation site and that everything is clearly arranged.
- Make sure that the gas meter is leak-proof!
- Leaks may produce ignitable air-gas mixtures. Caution: Danger of explosion!
- Do not open the oil level indicator or retighten the screw connections when the gas meter is pressurized.
- Comply with the manufacturers' instructions and general safety rules!
- Observe the technical rules of DVGW Code of Practice G 492/II.

Permissible positions of installation

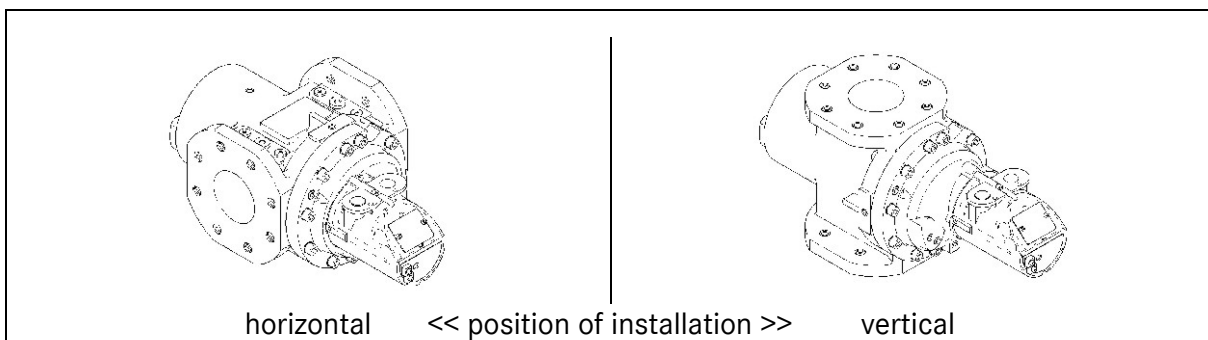

Notes on positions of installation

For sizes G 40 to G 400, the oil level indicators are located in such a way that the gas meters can be installed horizontally or vertically. Thus, the gas meters can be turned through 90° and only the totalizer casing has to be adjusted to the new position of use, without official supervision.

For sizes G 650 to G 4000, the oil level indicators and the fastening feet can be fitted in such a way that the gas meters can be installed horizontally or vertically. Thus, the gas meters can be turned through 90° and only the totalizer casing has to be adjusted to the new position of use, without official supervision.

The bending and torsional forces acting on the gas meter must not exceed the following values:
 DN 50 - 300 Nm DN 80 - 500 Nm DN 100 - 800 Nm DN 150 - 1800 Nm

The length of engagement of the flange screws must be 1.25 to 1.5 x thread diameter.

Tightening torques for flange screws:

M 16	5.6	85 Nm	24 mm effective length of engagement
M 20	5.6	170 Nm	30 mm effective length of engagement

Impermissible modes of operation

- Opening the gate valves in the piping too fast. In the case of a pressure difference of approx. 3 mbar, the gas meter already runs at Q_{max} .
- Filling up or draining oil as long as the gas meter is pressurized.
- Exceeding Q_{max} .
- Position of installation in accordance with the illustration.
- Gas temperatures below -10°C or above $+40^{\circ}\text{C}$.

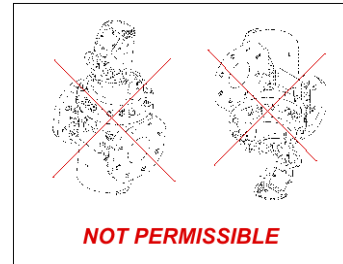

Transport, storage and installation



When **transporting** the rotary displacement meter, always observe the following points:



- Rotary displacement meters are supplied **without oil**.
- Transport is only permitted if there is **no oil** in the gas meter.



- The connecting flanges are closed with plastic covers to prevent foreign particles entering.



- The gas meters are painted ready for use. Plates, totalizer casings and official seals must not be painted.
- Protect the gas meters and their accessories against impacts and shocks during transport.
- Use appropriate lifting gear for transport.

When **storing** gas meters:

- Store the gas meters in a dry and protected room.
- Store the gas meters only at temperatures from -20°C to $+60^{\circ}\text{C}$.
- Apply an appropriate low-viscosity preservative oil to the flange surfaces.

Observe the following points during **installation**:

- Observe the technical rules of DVGW Code of Practice G 492/II.
 - Remove the sealing caps from the flange openings.
 - The piping to be connected must be free from foreign particles, such as welding beads or similar particles. Inert gas welding should be preferred to other welding techniques as there is less contamination.
-

- Install a (conical) strainer for the first 500 operating hours to avoid damage due to impurities. If the strainer remains clean, replace it with an intermediate ring with a new seal. Start-up strainers are available from RMG.
- Install the rotary displacement meter at even, vibration-free connections without inclination. Tighten the flanges uniformly at the circumference. For permissible tightening torques, see chapter "Permissible positions of installation".
- Check whether the rotary pistons are running smoothly. If they are stiff, this indicates either distortions or impurities in the measuring chamber.
- Fix the piping separately in place to achieve a sturdy connection. Take appropriate measures to get the station's own weight and thermal expansions under control.
- In the case of long pipelines, install expansion bends.
- Connect pipelines without any stress.
- If there is formation of condensate or accumulation of dirt, install adequate separators in the pipeline upstream of the gas meter. Here the recommended direction of flow is from the top to the bottom.
- When designing the station, also comply with the component suppliers' safety instructions and technical documents.
- Check the readily installed gas meter for leaks in compliance with the relevant local gas supply rules and regulations (for example, DVGW Codes of Practice G492, G469 and G496 in Germany) under the supervision of an expert.
- **Prior to commissioning, fill the gas meter with oil.** This must not be done unless the gas meter is installed and unpressurized!

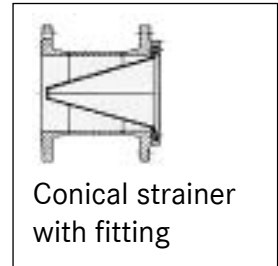

Defining the direction of flow

The gas meter is fitted with a double digital index. Thus, the gas meter can be **adjusted** to the direction of flow during commissioning without changing the totalizer and without official supervision.

This is how to do it:

The arrows indicating the direction of flow and the digit rollers are covered by a perforated plastic plate.

The direction of flow determines which section of the perforated cover plate is to be broken off.

Example	Arrow indicating the direction of flow	Digit rollers
Desired direction of flow	Section to be broken off (Fig. 1)	Direction of flow becoming visible (Fig. 1a)
To the right or to the bottom	Section 1	A acc. to example
		Section to be broken off (Fig. 2)
		Digit rollers
		Direction of flow A
		A visible

In the case of **direction of flow A**, **direction of flow A** is to be broken off.
 In the case of **direction of flow B**, **direction of flow B** is to be broken off.

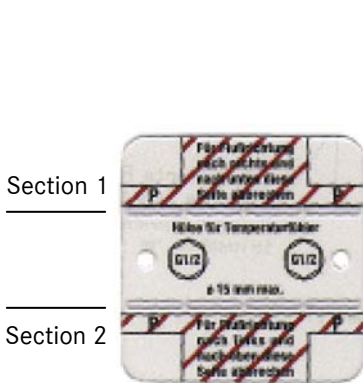

Fig. 1: Cover of the arrows indicating the direction of flow



Fig. 1a: Cover broken off for direction of flow to the right and to the bottom

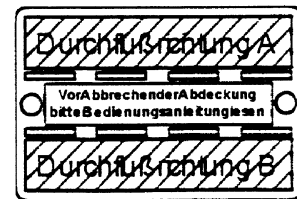

Fig. 2: Cover of the digit rollers

The remaining covers are to be secured appropriately against unauthorized removal.

Adjusting the totalizer

- Adjust the totalizer casing depending on the direction of flow so that you can read the digit rollers (item 10) horizontally.

To do this,

- unscrew the hexagon socket screws (item 6);
- turn the totalizer casing (item 13) through 90°;
- screw in the hexagon socket screws (item 6).

Positioning the totalizer:

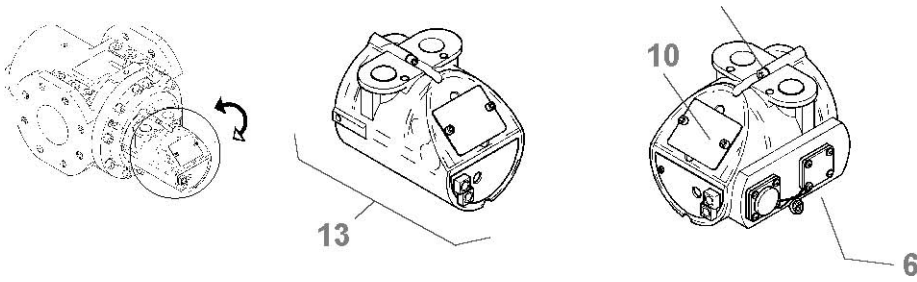

Commissioning or start-up

Install the rotary displacement meter in accordance with chapters 4, 5 and 6 of these operating instructions.



In accordance with DVGW G 492, commissioning has to be performed under the supervision of an expert, while appropriate safety measures have to be taken.



During commissioning, fill the gas meter with lubricating oil after it has been installed (see chapter 9.2). Check the oil filler, oil level and oil drain plugs for tight fit and leaks.



Check the direction of flow (see also chapter 7).



Slowly open the gate valves of the piping.

Mind the pressure difference. The pressure difference must not exceed 3 mbar.

The rotation of the pistons is made visible by the black and white segmental disk in the totalizer casing.



Now the gas meter is ready for operation!

Servicing and maintenance

Servicing and maintenance comprises the following items:

Maintenance schedule – Lubricant change – Lubricant regulations – Servicing and troubleshooting table

If you have any doubt or question, please contact RMG's Customer Service. In this case, please provide the following information:

- Order number, serial number and meter size.
- Describe the trouble or fault occurred as accurately as possible.
- State troubleshooting measures previously taken.

If the gas meter is sent to the supplying plant, make sure that you take the following measures:

- Before you remove the gas meter, drain the oil. The gas meter has to be transported without oil, otherwise it would be deemed to be transportation of dangerous goods.
 - Close the flanges with blind covers.
-

Maintenance schedule

Period of time	Lubrication		Deadlines for subsequent verification	Start-up strainer
	G40-G400	G650-G4000		
Every 6 months		Check oil level.		
After 500 operating hours				If the start-up strainer remains clean, it can be removed.
Every 5 years Measuring clean and dry gases Measuring very pure gases	Change oil. Check oil level.	Change oil. Check oil level.		
After 16 years	* Change oil when measuring dry and very pure gases.		Sizes up to and including G1000	

* When natural gas or gases of highest purity are measured where no contamination of the lubricating oil by gas dusts or impurities is to be expected according to the operator's experience, the oil can be changed at intervals of 16 years.

Type: G 1000 and smaller

Gas meters have to be sent to the manufacturer's factory or an officially authorized testing laboratory for subsequent verification. If the deadline for verification has expired, the gas meter must no longer be used or kept ready for billing purposes.

Type: G 1600 and larger

The gas meters of types G 1600 and larger need not be subsequently verified.

Lubricant change

CAUTION! To fill up or change oil, put the gas meter out of operation and relieve the measuring line in compliance with the safety regulations DVGW G491 II and G 495 II.

- ➔ Do not fill up lubricating oil until the gas meter is completely assembled and installed.
- ➔ It is essential to make sure that both oil chambers are separately filled or drained.

Filling up oil

G 40 - G 400

G 650 - G 4000

Open oil filler plugs
Fill up oil ...

G 40 - G 400
horizontal

G 650 - G 4000
horizontal

G 40 - G 400
vertical

G 650 - G 4000
vertical

... until lubrication oil leaks from the oil level inspection hole

Items:

Oil level plug / oil level indicator	1
Oil filler plug	2
Oil drain plug	3

min. oil level = centre of sight glass
max. oil level = 2 mm above centre of sight glass

G 650 - G 4000

Insert screw plugs with new seals and tighten them.
Check them for tight fit and leaks!

Draining oil

- ➔ Unscrew the screw plug. See also the detailed overview.
- ➔ Collect the waste oil and dispose of it properly.
- ➔ Reinsert the screw plug with a new sealing ring and check it for leaks.

Quantities of lubricating oil required

Size	Pressure rating	Total quantity of oil in litres (approx.) with	
		vertical flow direction	horizontal flow direction
G 40	16 bar	0.25	0.07
G 65	16 bar	0.25	0.07
G 65 / 100	16 bar	0.28	0.13
G 160	16 bar	0.28	0.13
G 250	16 bar	0.96	0.18
G 400	16 bar	0.96	0.18
G 650	10 bar	3.10	2.40
G 650	16 bar	7.50	7.50
G 1000	10 bar	3.10	2.40
G 1000	16 bar	7.50	7.50
G 1600	10 bar	9.00	4.20
G 1600	16 bar	21.00	21.00
G 2500	10 bar	10.50	7.60
G 2500	16 bar	32.00	32.00
G 4000	10 bar	10.50	7.60
G 4000	16 bar	32.00	32.00

Lubricant regulations

DIN 51 519 up to G 4000 ISO-VG 10

Servicing and troubleshooting table

Fault	Possible cause(s)	Corrective action(s)
Abnormal running noises	<ul style="list-style-type: none"> - Damage to the bearings. - Rotary pistons come into contact either with each other or the wall of the measuring chamber. - Contaminated rotary pistons. 	<ul style="list-style-type: none"> - Gas meter is to be sent to the manufacturing plant. - Clean rotary pistons.
Oil in the measuring chamber	<ul style="list-style-type: none"> - Oil level is too high. - Transport with oil filling. - Oil was filled up, although the gas meter was not installed. 	<ul style="list-style-type: none"> - Correct / drain rinse / dry
Pressure loss is too high / inlet, outlet	<ul style="list-style-type: none"> - Contaminated start-up strainer - Contaminated measuring chamber and/or rotary pistons. 	<ul style="list-style-type: none"> - Clean / remove - Clean

After each intervention due to a fault of the rotary displacement meter, conduct the following checks:

- ➡ Smooth running
- ➡ Contactless rotation
- ➡ Proper functioning
- ➡ No leaks

If there is any kind of resistance, do not put the gas meter into operation!

After commissioning or start-up, observe the gas meter carefully!

Spare parts and accessories

We expressly point out that genuine parts and accessories which were not supplied by us have neither been tested nor approved by us. Therefore, the installation or connection of such products might affect the specific design properties of the stations. We shall not accept any liability for damage caused by using parts or accessories which are not genuine.

Removing the gas meter

If the rotary displacement meter is to be removed for inspection, subsequent verification, repair, etc., make sure that you comply with the relevant safety instructions and local rules and regulations when putting it out of operation. Before removing the gas meter, depressurize the gas pipes, purge them with neutral gas and drain the oil.

If the gas pipe cannot be purged with neutral gas, you can also vent it to the outside, taking all necessary safety measures. Avoid the formation of ignitable air-gas mixtures.

Caution! Improper handling involves risks of explosion and poisoning!

Do not transport the gas meter if it is filled with oil!

Accessories

Installable pulse generators for the CL 98 totalizer

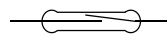
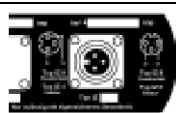
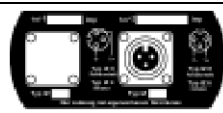
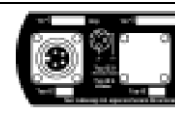
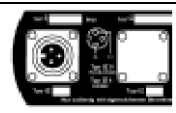
Technical data	Type IZ4 option	Type IZ6 option	Type IZ8 option	Type IZ9-2 option	IZ9 standard
Possibility for installation	Only at the factory		At the factory or on site under official supervision		
Switching element/ type of contact	Proximity switch, inductive 		Reed switch, isolated contact 		
Contact load	Acc. to intrinsically safe circuit (Ex)i as per VDE 0165				
Degree of protection	IP67 when plugged in				
Position of installation in the totalizer					
Pin assignments of the angle plug	3-pin, DIN 41524 pin 1+ / pin 3-		4-pin I1=pin 1/pin 4 I2=pin 2/pin 3	3-pin, DIN 41524 pin 1 / pin 3	
Pulse value of meter type/size				Double pulse I1=I2	
G40 to G65	0.01 m ³ /pulse ≈100 pulses/m ³		0.01 m ³ /pulse ≈100 pulses/m ³	0.1 m ³ /pulse ≈10 pulses/m ³	0.1 m ³ /pulse ≈100 pulses/m ³
G100 to G650	0.1 m ³ /pulse ≈10 pulses/m ³	Pulse value, see type plate	0.1 m ³ /pulse ≈10 pulses/m ³	1.0 m ³ /pulse ≈1 pulse/m ³	1.0 m ³ /pulse ≈1 pulse/m ³
G1000 to G4000	1.0 m ³ /pulse ≈1 pulse/m ³		1.0 m ³ /pulse ≈1 pulse/m ³	10 m ³ /pulse ≈0.1 pulse/m ³	10 m ³ /pulse ≈0.1 pulse/m ³

Subsequent installation



In the case of verified gas meters, pulse generators may be installed subsequently only under official supervision!

1. Remove the cover (item 1) together with the seal (item 2).
2. Install the pulse generator (item 3) with the new seal (item 4) in the totalizer casing. Make sure that the guiding groove is correctly located (see table: Position of installation in the totalizer).
3. Screw the capstan screw (item 5) in the lower left threaded hole.
4. Screw in the remaining 3 screws (item 7) but do not overtighten them.
5. Remove the protective cap (item 6).
6. Install the angle plug. In the case of proximity switches, make sure that the pin assignments are correct (see table).
7. After you have checked the pulse value, permanently punch it together with the type designation in the relevant fields of the totalizer's type plate using punch numbers and letters or similar means.

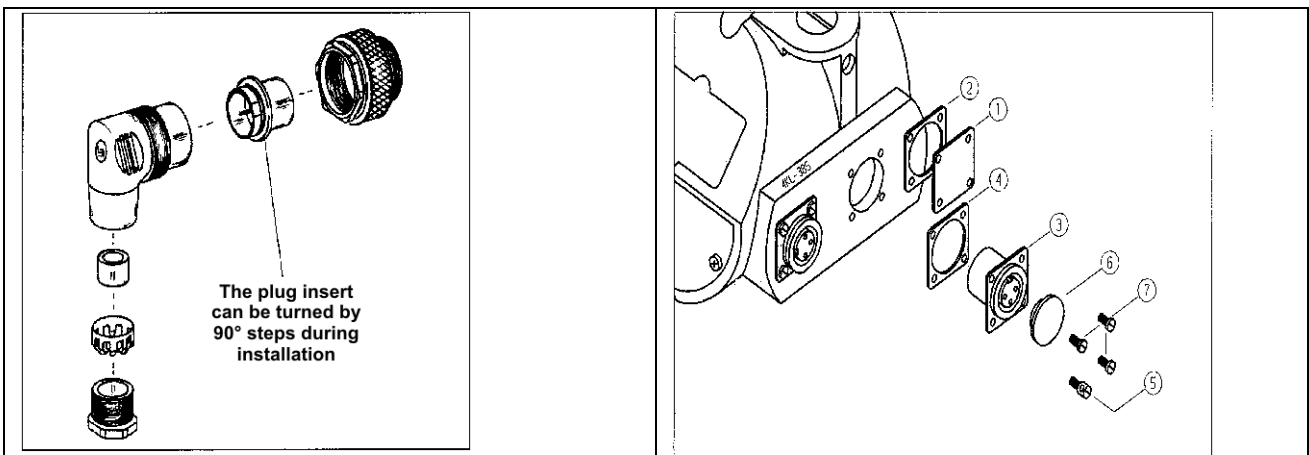
NOTE! Make sure that the unit of measurement of the pulse value is correct (m^3/dm^3).

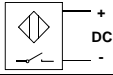
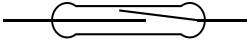

Pulse generators for connection via a mechanical drive shaft

Technical data		Type IZ10	Type IZ11	Type IZ12 double pulse	Type IZ50	Type IZ51	Type IZ52 double pulse	Type IZ111
Switching element		Slot proximity switch 			Reed switch 			Diode
Type of contact		Inductive			Isolated contact			 CAUTION! Type IZ 111 has not been approved for areas subject to explosion hazards.
Contact load		Acc. to intrinsically safe circuit (Ex)i as per VDE 0165						
Degree of protection		IP67 when plugged in						
Pin assignments of the plug  4 pins		Pin 1+ / pin 2-	I1=pin 1+ / pin 2- I2=pin 3+ / pin 4-		Pin 1+ / pin 2-	I1=pin 1+ / pin 2- I2=pin 3+ / pin 4-		
Switching frequency		$f = \frac{\text{Flow rate [m}^3/\text{h}]}{\text{Pulse value [m}^3\text{]} \cdot 3600} \dots \text{Hz}$						
Pulse value for meter size				Outputs I1=I2 or I1=I2		Outputs I1=I2 or I1=I2		
G40	Ua=0.01	0.001	0.0001	0.0001	0.005	0.001	0.001	0.0005 x Ua to 1 x Ua
G65		m ³ /pulse to 0.01 m ³ /pulse	m ³ /pulse to 1.0 m ³ /pulse	m ³ /pulse to 1.0 m ³ /pulse	m ³ /pulse or 0.01 m ³ /pulse	m ³ /pulse to 1.0 m ³ /pulse	m ³ /pulse to 1.0 m ³ /pulse	
G65/G100	Ua=0.1	0.01	0.001	0.001	0.05	0.01	0.01	
G160		m ³ /pulse to 0.1 m ³ /pulse	m ³ /pulse to 10.0 m ³ /pulse	m ³ /pulse to 10.0 m ³ /pulse	m ³ /pulse or 0.1 m ³ /pulse	m ³ /pulse to 10.0 m ³ /pulse	m ³ /pulse to 10.0 m ³ /pulse	
G250								
G400								
G650								
>G650	Ua=1.0	0.1	0.01	0.01	0.5	0.1	0.1	
		m ³ /pulse to 1.0 m ³ /pulse	m ³ /pulse to 100.0 m ³ /pulse	m ³ /pulse to 100.0 m ³ /pulse	m ³ /pulse or 1.0 m ³ /pulse	m ³ /pulse to 100.0 m ³ /pulse	m ³ /pulse to 100.0 m ³ /pulse	
Casing dimensions		∅D=90 mm L=36 mm	∅D=90 mm L=57 mm	∅D=90 mm L=36 mm	∅D=90 mm L=57 mm			

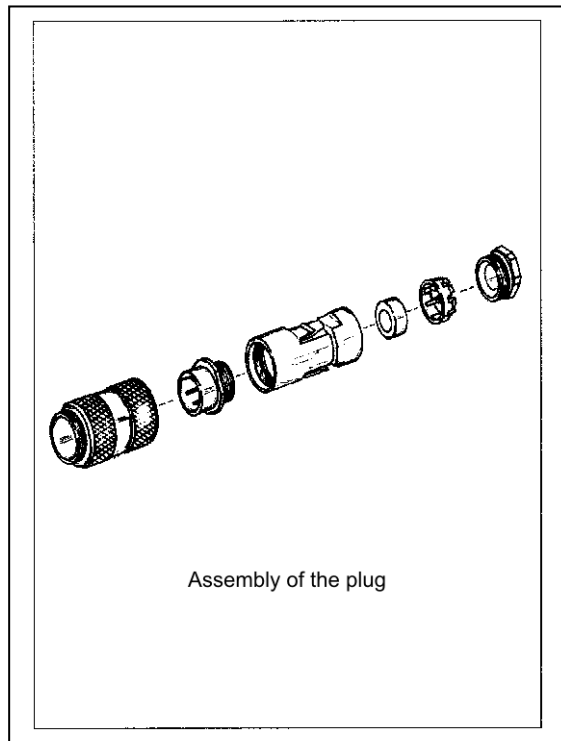
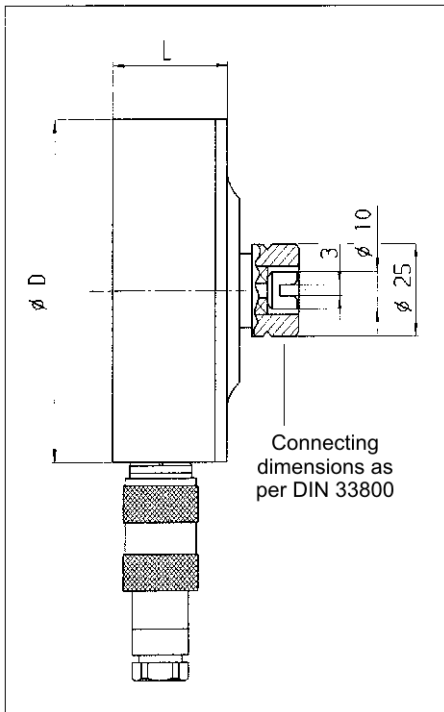

Mechanical drive shaft for the CL 98 totalizer

Installation of the mechanical drive shaft, e.g. for the ENCO-M

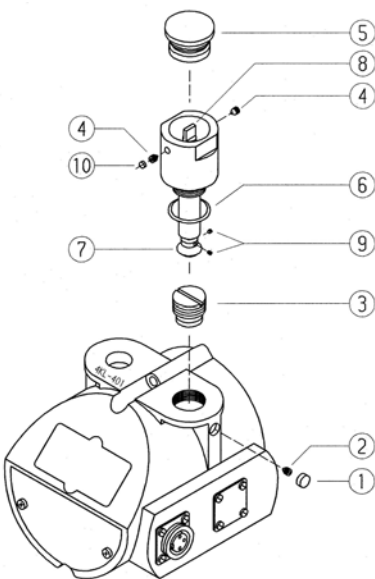

- 1 Verification mark
- 2 Setscrew
- 3 Screw plug
- 4 Setscrew
- 5 Plug
- 6 Seal
- 7 Bevel gear
- 8 Journal
- 9 Setscrew
- 10 Lead seal or adhesive label

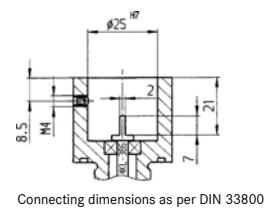

Gas meter	Output value	Max. connection torque with measuring range			
		1:20	1:50	1:100	1:160
Size	1 rotation	1:20	1:50	1:100	1:160
G40	0.01 m ³	5 Nmm	5 Nmm	5 Nmm	-
G65	0.01 m ³	5 Nmm	5 Nmm	5 Nmm	-
G65 to G400	0.1 m ³	20 Nmm	20 Nmm	5 Nmm	5 Nmm
G650	0.1 m ³			20 Nmm	
G1000	1.0 m ³			20 Nmm	-
G1600 to G4000					

Installation description

- In the case of verified gas meters, mechanical drive shafts may be installed subsequently only under official supervision!
- Remove the verification mark (item 1) and unscrew the setscrew (item 2).
- Loosen and remove the screw plug (item 3).
- Unscrew the two setscrews (item 4) and remove the plug (item 5).
- Screw the drive shaft with the seal (item 6) carefully into the totalizer casing as far as it will go. Now the bevel gear (item 7) will mesh with its mating wheel in the totalizer.
- Move the journal (item 8) to check the backlash of the bevel gear (item 7). The desired backlash is approx. 0.1 to 0.5 mm.
- If the backlash is too small, unscrew the mechanical drive shaft again, loosen the two setscrews (item 9) and shift the bevel gear (item 7) on the shaft upwards.
- Then retighten the setscrews (item 9). Check them for tight fit!
- Now screw the mechanical drive shaft again into the totalizer casing and check the backlash once again.
- NOTE! The bevel gear must run smoothly.
- If the backlash is correct, screw in the setscrew (item 2) again to secure the mechanical drive shaft and seal it.
- Close the mechanical drive shaft with the plug (item 5) or connect the intended downstream device.
- Screw in the setscrews (item 4) to secure the plug or downstream device and seal them with a lead seal or adhesive label (item 10).
- When you remove the mechanical drive shaft, it is essential to previously remove the setscrew (item 2).

Rotary displacement meters – items

Notes on the use of threaded sleeves

Item No. Designation (see detailed overview on page 21)

- 1 Oil level indicator (G650-G4000), oil level plug G1/8" (G40-G400)
- 2 Oil filler plug G1/8", sealing ring dimensions G40-G400 10x14 Cu3
- 3 Oil drain plug, sealing ring dimensions G40-G400 10x14 Cu3
- 4a Temperature measuring point, sealing ring dimensions 1/2" 21x26x2 Cu
- 4b Temperature-checking measuring point, sealing ring dimensions 1/4" 13.5x17x1.5 Cu
- 5 Pressure measuring points, sealing ring dimensions 1/4" 13.5x17x1.5 Cu
- 6 Fastening screw for totalizer casing
- 7 Connection for pulse generator IZ 9
- 8 Connection option for additional pulse generator IZ 4, IZ 6 or IZ 8
- 9 Installation option for mechanical drive shaft
- 10 Double digital index
- 11 Plate indicating the direction of flow
- 12 Main plate
- 13 Totalizer casing
- 14 Leaded casing screw

18

DKZ size	Code No. for 1/2" threaded sleeves	Code No. for 1/4" threaded sleeves
G40, G65, G100, G160	50.23.290.08	50.23.290.05
G160, G250, G400, G650	50.23.290.09	50.23.290.06
G1000	50.23.290.10	50.23.290.07

The assignments of threaded sleeves to meter sizes and nominal diameters are valid for direct installation in the gas meter case up to DKZ size G 400.

From DKZ size G 650 upwards, welding sleeves are to be installed in the piping. When welding sleeves are used, it is essential to consider their lengths. Threaded sleeves have to project into the gas flow from the centre of the pipeline.

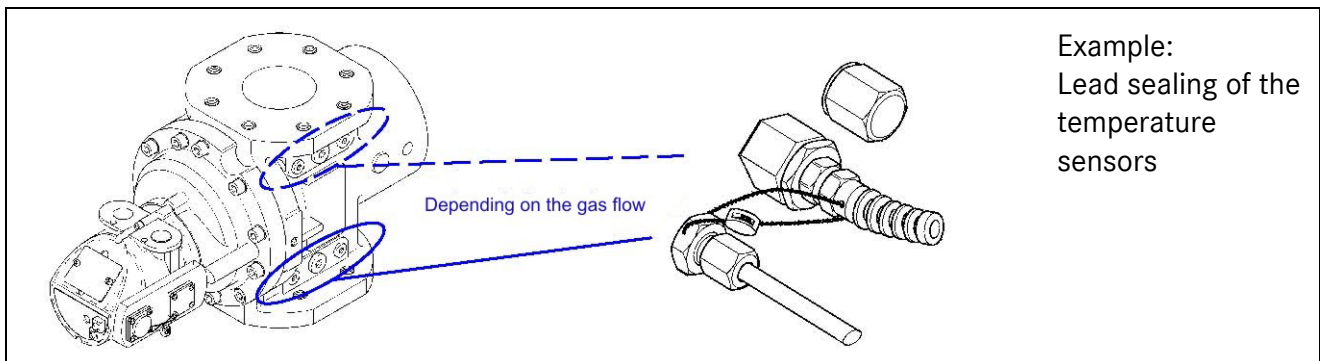

Rotary displacement meters – Detailed overview

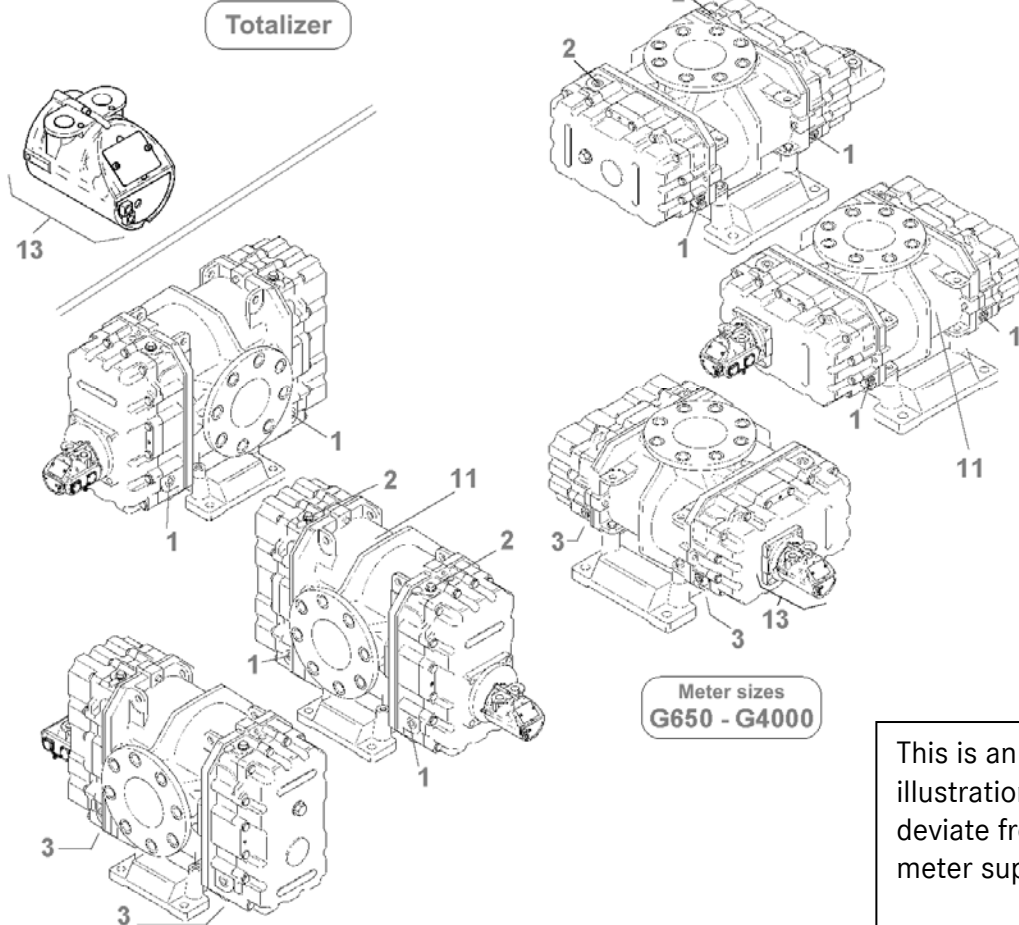
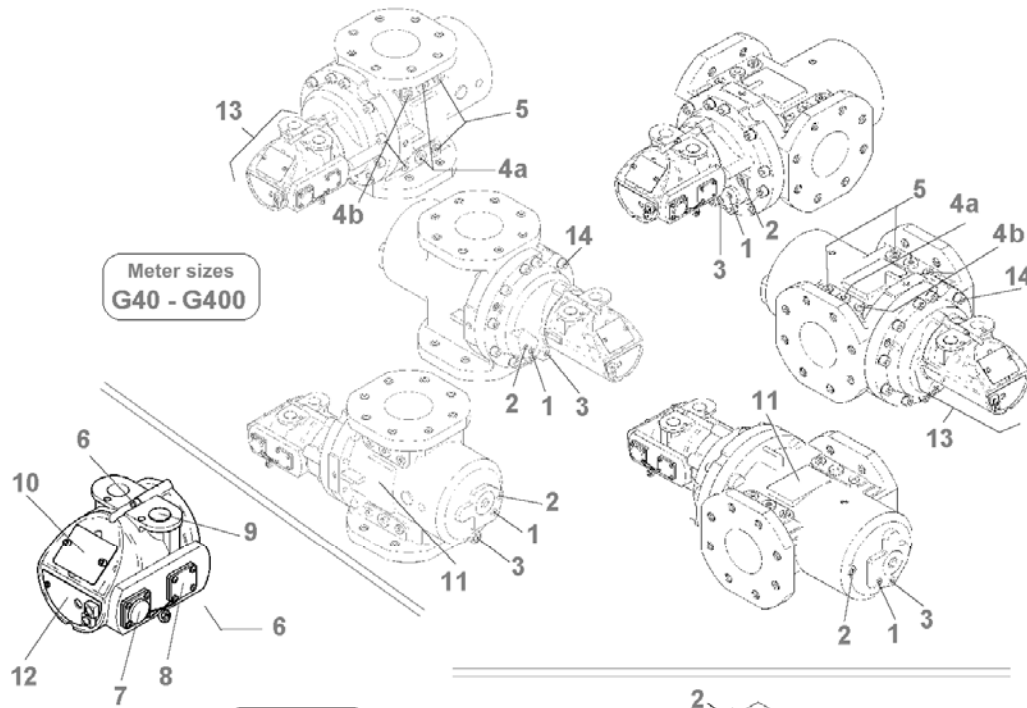

This is an exemplary illustration. It may deviate from the gas meter supplied.

Recycling and disposal

- All waste products are to be disposed of or treated in an environmentally safe way.
- Used lubricants are to be disposed of properly.
- Contaminated components and auxiliary materials are to be packed and decontaminated.

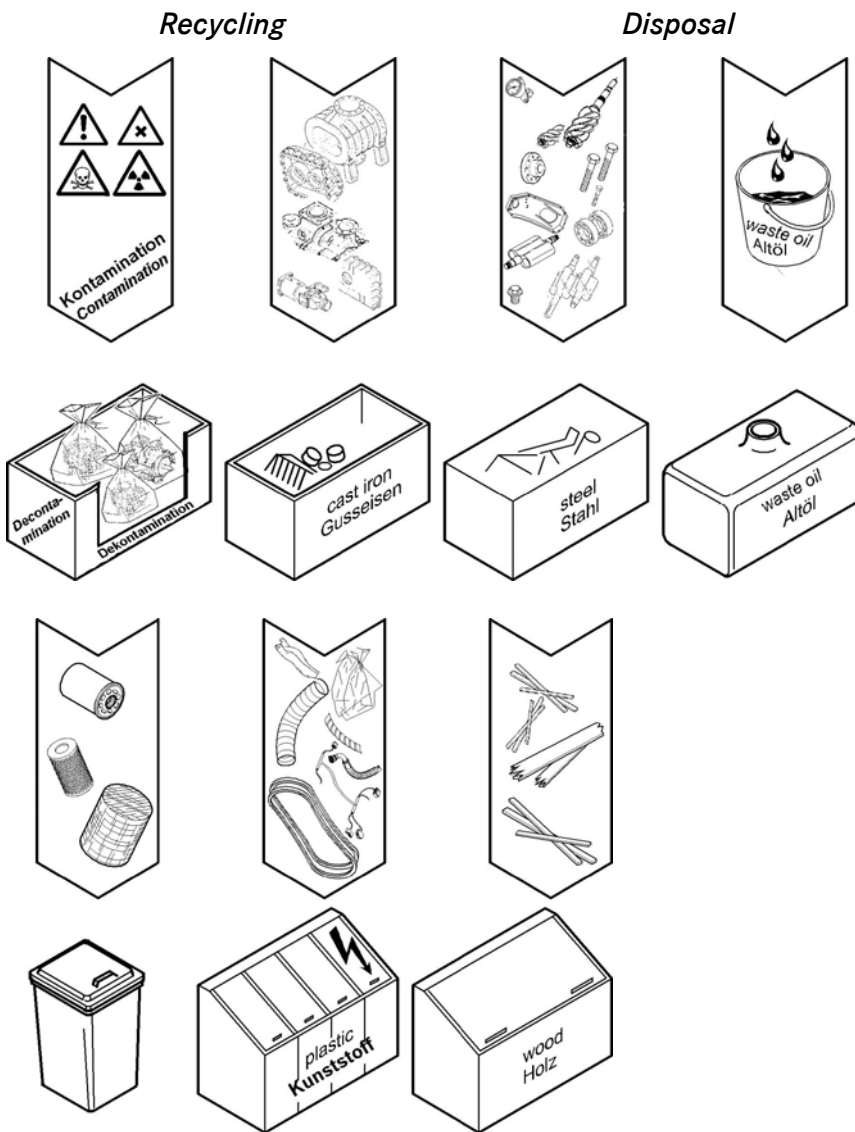

Information page

We reserve the right to change the descriptions and statements contained in these operating instructions insofar as this proves necessary to improve our rotary displacement meters.

Please follow the instructions and note the changes which might be stated on this page!

