

# Bus Coupler for Multistream PGC

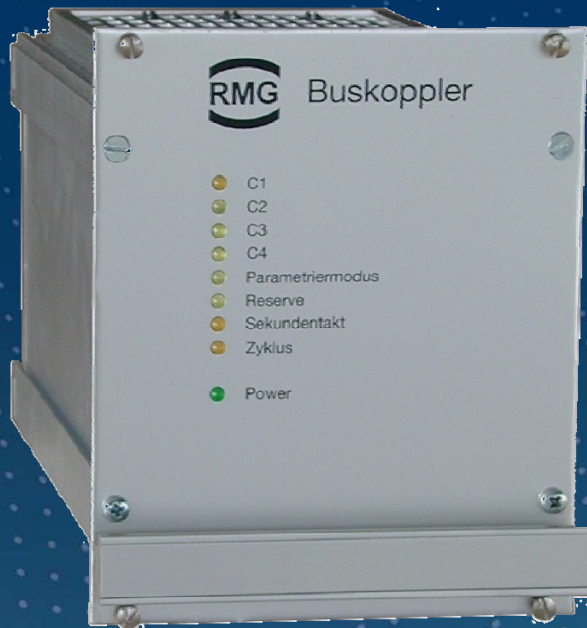

## OPERATING INSTRUCTIONS

**Serving the Gas  
Industry Worldwide**

---

**Note:**

Unfortunately, paperwork does not automatically update itself but technical developments are constantly being made. Therefore, we reserve the right to change the descriptions and statements contained in our operating instructions without prior notice. However, you can conveniently download the most recent version of this manual (and those of other devices) from our website [www.rmg.com](http://www.rmg.com).

**RMG Messtechnik GmbH**

Otto-Hahn-Str. 5

35510 Butzbach (Germany)

Fax: +49 (0)6033 897-130

E-mail: [RS-HPS-Messtechnik@Honeywell.com](mailto:RS-HPS-Messtechnik@Honeywell.com)**Phone numbers:**

Switchboard: +49 (0)6033 897-0

Customer Service: +49 (0)6033 897-127

Spare Parts: +49 (0)6033 897-173

<b>DESCRIPTION OF THE UNIT</b> .....	<b>1</b>
<b>ELECTRICAL CONNECTIONS</b> .....	<b>2</b>
<b>TERMINAL CONFIGURATION</b> .....	<b>3</b>
<b>SETTING THE BUS COUPLER PARAMETERS</b> .....	<b>4</b>
DIL switch.....	4
The P9000 operating program .....	4
<b>CONVERTER BETWEEN MULTISTREAM PGC AND THE DSFG INTERFACE</b> .....	<b>5</b>
Function of the bus coupler.....	5
Block diagram .....	5
Proprietary bus .....	6
Bus coupler .....	6
DSfG .....	6
Visual comparison of measured values .....	6
Data security .....	7
<b>Absence of feedback</b> .....	<b>7</b>
Absence of electrical feedback.....	7
Absence of logic interaction .....	8
<b>FUNCTIONS OF THE RMG BUS E</b> .....	<b>9</b>
<b>ANNEX</b> .....	<b>10</b>
<b>Data flow explained</b> .....	<b>10</b>
Bus coupler for the DSfG on a multistream PGC.....	10
Basic design:.....	Fehler! Textmarke nicht definiert.
Data flow:.....	Fehler! Textmarke nicht definiert.
Switching on procedure .....	11
Normal operation (data exchange).....	12
Parameter range .....	13

## CONTENTS

---

---

## Description of the unit

The bus coupler is mounted in a 19" cassette with 3 HEs and 21 TEs

It is designed exclusively for a power supply of 24 V DC. If the voltage is different a suitable power pack must be connected in the incoming circuit

The front panel includes LEDs that display the current status of the device. The LEDs glow or flash to show activity at the individual interfaces.

### Example:

o C1	LED on = data transfer in progress
o C2	LED on = data transfer in progress
o C3	LED on = data transfer in progress
o C4	LED on = data transfer in progress
o Parameter setting	LED on = flashing LED means that parameterisation mode is active
o Spare	
o Clock pulse	LED on = display flashes every second
o Cycle	LED on = display flashes in calculation cycle
o Power	LED on = device is ready to operate

### Front panel:

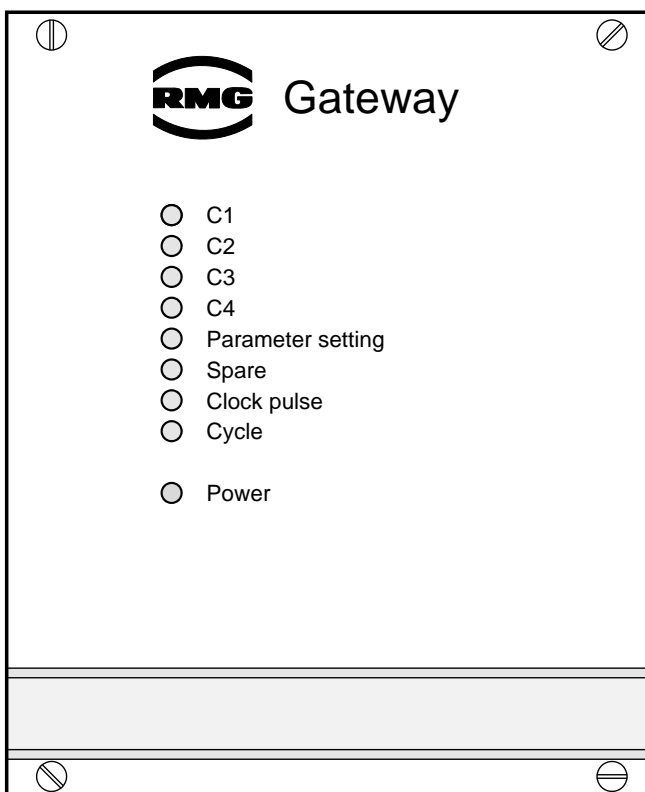

# Electrical connections

All data lines are connected to 9-pin sub D plugs on the rear panel of the bus coupler. Depending on the model, 3, 5 or 6 plugs are available, however no more than 4 interfaces can operate at the same time.

## Interface types:

- C1 RS 232
- C2 RS 485 (Standard: DSfG)
- C3 RS 232
- C4 RS 232
- C5 RS 485 (can be used for RMG bus or MODBUS with the appropriate software)
- C6 RS 485 (can be used for MODBUS with the appropriate software)

## Rear panel:

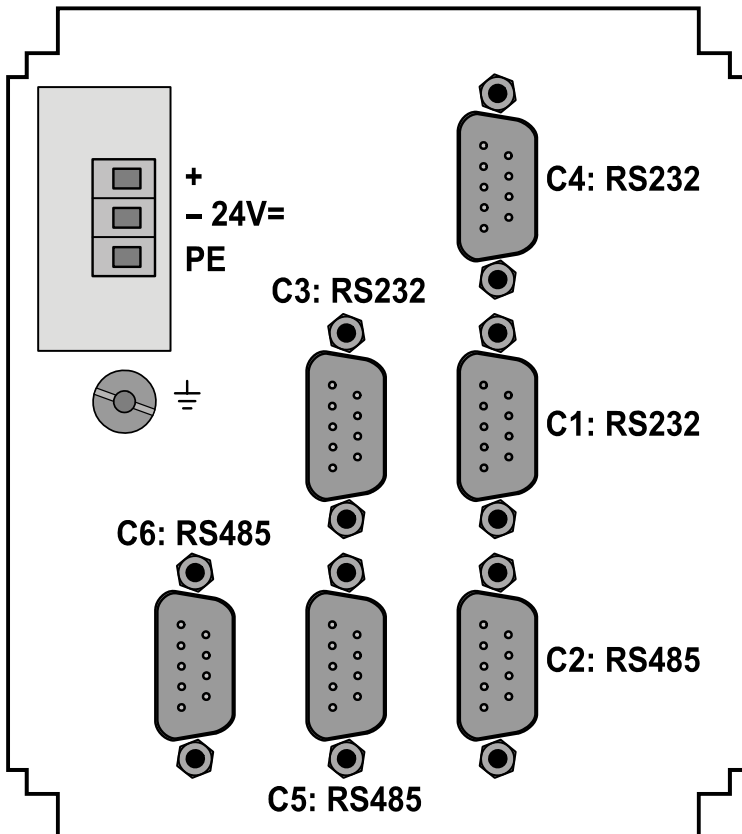

# Terminal configuration

With a combination of “**converter between Multistream PGC and the DSfG interface**” and a Multistream PGC and a number of DSfG interfaces (one per stream), the bus coupler connections are as follows:

C1	If DIL 1 = on, the parameters are set with an external PC and the P9000 operating program
C2	DSfG terminal
C3	not used
C4	not used
C5	RMG bus, connection to PGC 9000 VC
C6	not used

## Setting the bus coupler parameters

### DIL switch

On the underside of the bus coupler is an opening through which an 8-pole DIL switch can be accessed. This switch can be used to change the operating mode of terminal C1.

DIL switch 1 = on: Terminal C1 = parameter setting interface working bidirectionally with P9000

DIL switch 1 = off: Terminal C1 = PGC terminal, for retrieving data from the PGC

If the DIL switch 1 is on, the bus coupler can be programmed with a notebook on which operating program P9000 is installed.

Parameters: DSfG address, preset, baud rate etc.  
RMG bus address, preset, baud rate, etc.  
Transmit cycle to FE-09  
Criteria for switching over

If the DIL switch is set to off, the bus coupler starts to send data at the preset intervals. It is then no longer possible to use this interface to write to the bus coupler.

### The P9000 operating program

The P9000 program is used to set the parameters of a bus coupler. In the same way as for the coordinate display of an ERZ 9000 volume corrector, the bus coupler has a system of coordinates for setting the parameters of the desired functions. This is an important function as the bus coupler has neither display nor keyboard.

The P9000 has its own separate documentation. The program recognises the different versions of the bus coupler and reads an identifier at the start of communication so it can identify the device to which it is connected.

---

# Converter between Multistream PGC and the DSfG interface

Bus coupler for process gas chromatograph (single stream or multistream) where applications have more than one DSfG interface

## Function of the bus coupler

The bus coupler acts as a converter between a proprietary interface and the DSfG. This is always required if a PGC is to serve a number of DSfG circuits, or if a multistream PGC must offer a DSfG interface for each stream. Since, for reasons of space, only one DSfG interface or proprietary interface is available, the PGC has to be expanded by the number of bus couplers that are needed on each occasion. The combination of bus coupler and PGC thus becomes a unit. Although the data link runs through an external cable, this is treated as an internal connection and is protected.

## Block diagram

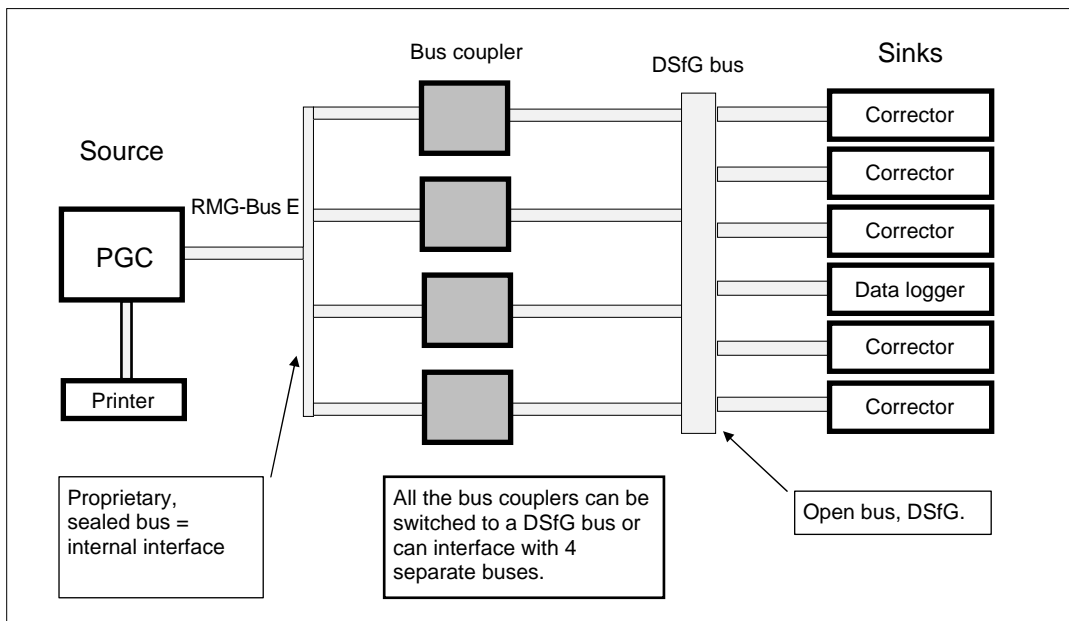

### Proprietary bus

The MODBUS protocol is taken as a basis and modified accordingly. This is done using the original hardware interface of the DSfG. The wiring, the structure of the master cable, the individual lines and the location of the terminating resistors are thus the same as the original DSfG (or DIN 66348). This option already exists as an “RMG bus” for connecting a PGC directly to a number of volume correctors.

This “RMG bus” is already approved and is expanded in such a way that in addition to receiving the measured values, it receives the constants needed for the DSfG side so that it can respond to all DSfG queries. This expanded bus is called the RMG bus E.

### Bus coupler

Inside, the bus coupler uses the same DSfG interface board as the PGC or the Series 9000 volume corrector. For reasons of space the board is installed in the cassette outside the PGC 9000 VC. The data connection with the PGC is declared as an internal interface, firmly secured and sealed. The bus coupler receives the measurements and constants from the PGC, stores them temporarily and passes the data on when needed to the DSfG in accordance with its rules.

### DSfG

Familiarisation with the DSfG is assumed.

### Visual comparison of measured values

A visual comparison of the officially relevant data can also be done between the data source (PGC) and the sink (e.g. volume corrector). The fuel value, standard density and carbon dioxide measurements shown on the PGC display are also shown on the volume corrector display.

## Data security

1. The RMG bus E uses the CRC-16 procedure to protect data as it is transferred from the PGC to the bus coupler.
2. On the DSfG side there are the familiar CRC-12 procedures with presets for signature, plausibility testing and timeout monitoring. The preset for calculating the signature is transmitted from the source in the bus coupler and in accordance with the DSfG rules the source preset must agree with the sink preset for the data to be recognised as valid. In multistream applications, the timeout in the sink is set according to the switchover times of the stream.

## Absence of feedback

### Absence of electrical feedback

3. Feedback on the PGC  
The necessary tests were run as part of the EMC tests for the CE mark and these confirmed the absence of electrical feedback.
4. Feedback on the DSfG interface  
The DSfG interface has passed the test for absence of electrical feedback as part of the extension to approval for the PGC and Series 9000 volume corrector.
5. Feedback on the bus coupler itself  
The bus coupler only serves approved and tested interfaces in both a primary and a secondary capacity. If it were to be affected by an electrical fault this would have no effect on either the primary or the secondary circuit.

### Absence of logic interaction

1. DSfG secondary circuit

The absence of logic interaction in the DSfG is amply described and documented in its specification. We, the manufacturer, confirm that this specification is complied with.

2. RMG bus E primary circuit

Apart from the live signal and its acknowledgement, data on the RMG bus flows **from the PGC to the bus coupler**. It is not possible to send data from the bus coupler to the PGC. The PGC is always the bus master and the bus coupler is always the slave. Based on the MODBUS commands, the following options are possible:

PGC	to	Bus coupler:	Transmit data
Bus coupler	to	PGC:	Positive acknowledgement of data transmission
PGC	to	Bus coupler:	Read data, query live signal
Bus coupler	to	PGC:	Acknowledge live signal query
Bus coupler	to	PGC:	Send negative acknowledgement

# Functions of the RMG bus E

## Broadcast measured value

A template for every new analysis or an event gives rise to a broadcast on the bus with new measured values and the stream number.

## Individual query

The bus couplers that are present are regularly polled for their Modbus addresses and a live signal in the form of a time-stamped response is expected.

## Live signal

The response includes transmission of a status byte showing the status of the bus coupler in respect of full data contents. The bus coupler uses this status to show whether all the data needed to map the PGC on the DSfG side is present. The acknowledgement signal is time-stamped.

## Transmit standard data

If the status byte shows that the data needed to map a PGC on the DSfG side is incomplete, the PGC sends a complete data set separately to the bus coupler concerned.

## Acknowledgement signal

For data transmissions that do not use the broadcast address 0, the source of the data waits for an acknowledgement signal that shows whether everything was correctly received.

## Time synchronisation

Automatic time synchronisation is only allowed once a day within a time window of 20 seconds. Series 9000 equipment already performs this function, as PGC or as volume corrector, within the scope of the DSfG. The same rules apply when using the RMG-Bus E. The current time can be taken from the time stamp of the positive acknowledgement in the live signal from the bus coupler.

# Annex

## Data flow explained

### Bus coupler for the DSfG on a multistream PGC

Basic design:

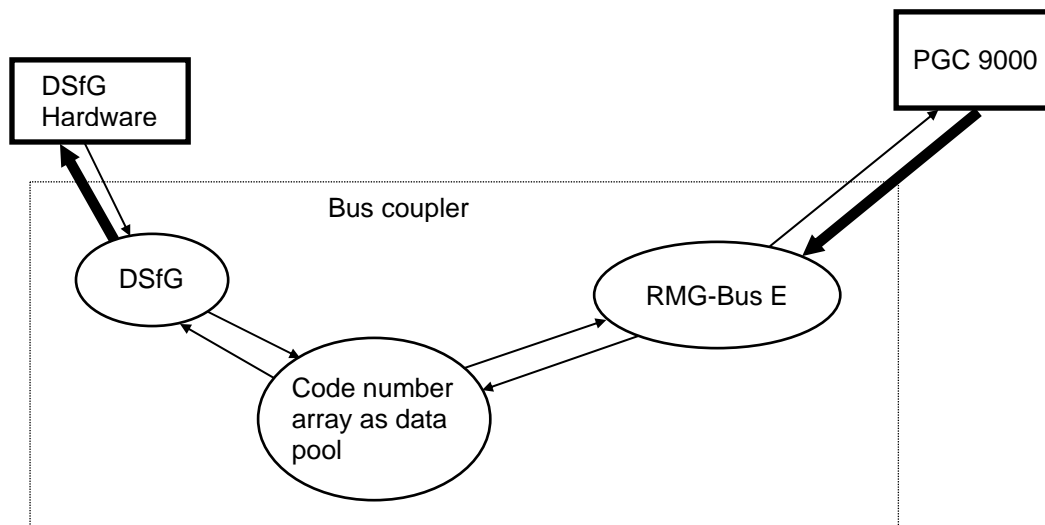

**Data flow:**

PGC → Bus coupler (RMG bus E)

The PGC forms data sets and sends them to the bus coupler. The format of the measured values is not modified, i.e. floating-point values and integers are unchanged.

Menu texts are interpreted as figures, e.g. 1 = Text 1, 2 = Text 2 etc. Time and date are transmitted as hh:mm:ss and DD:MM:YY and converted to DSfG format.

Bus coupler → PGC (RMG bus E)

The acknowledgement signal BK = blank, including the time and the time zone conversion for synchronisation, is the only information transmitted from the bus coupler to the PGC.

Bus coupler → DSfG (via internal link)

All data is converted to DSfG format, without any interpretation, it is simply passed on transparently.

## Switching on procedure

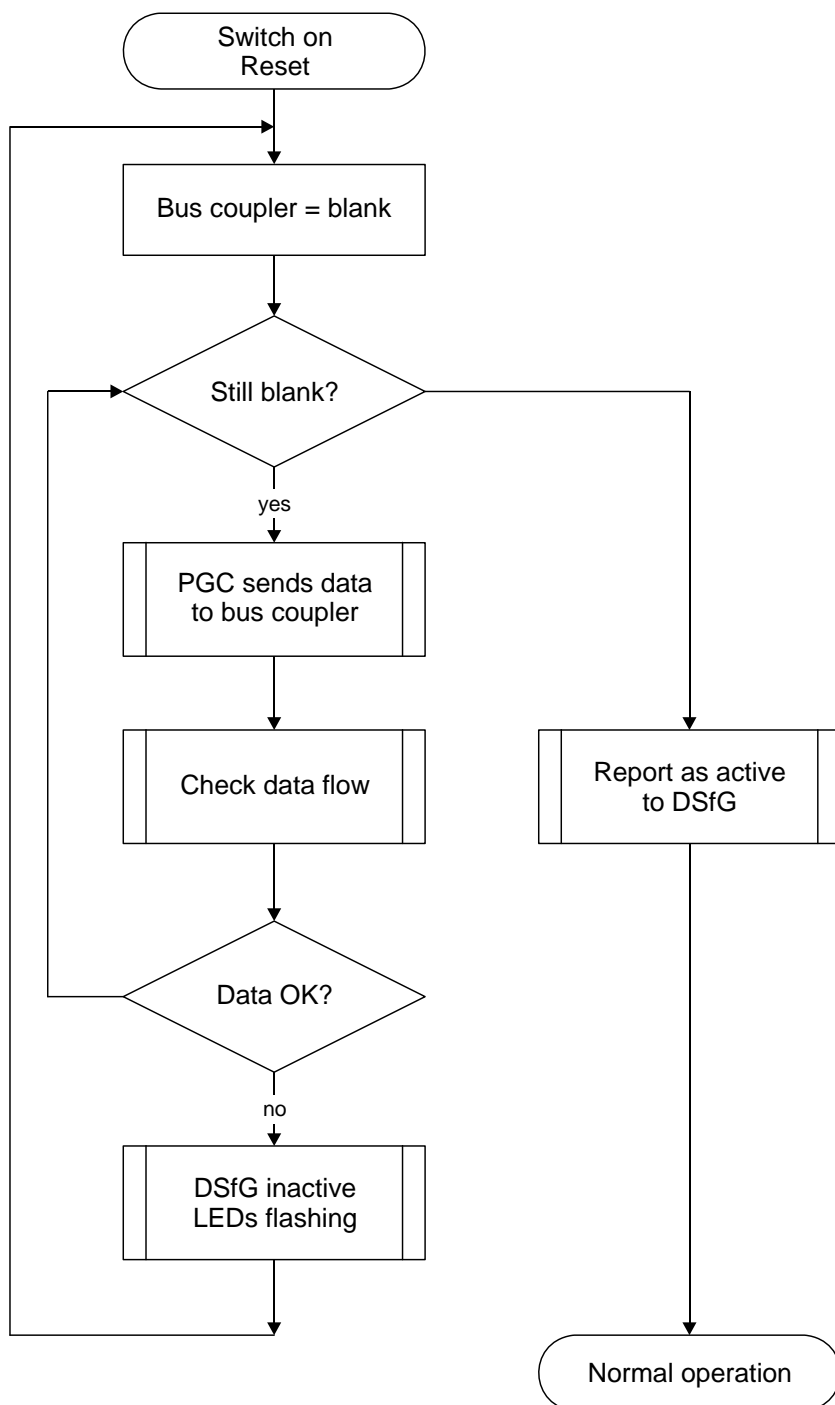

Normal operation (data exchange)

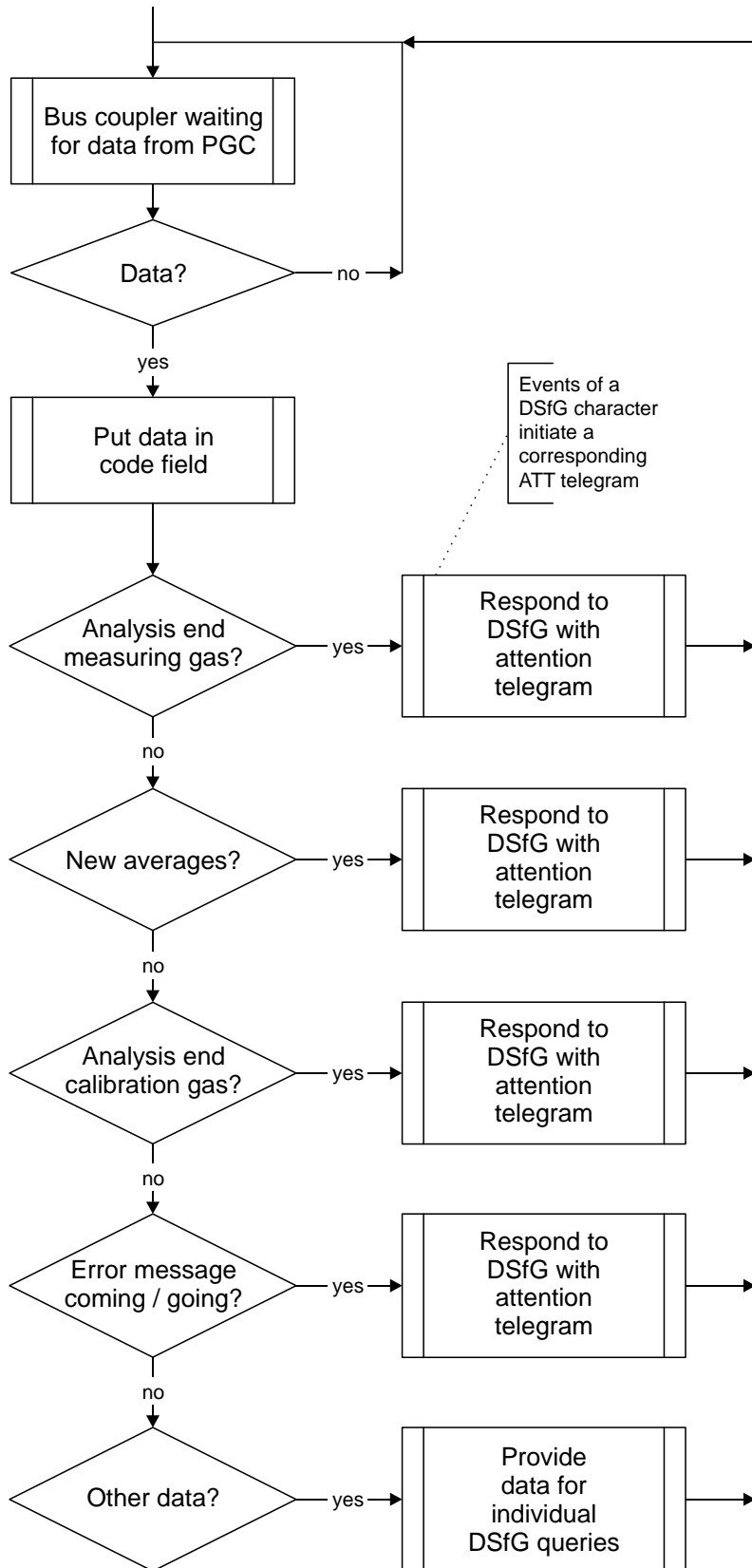

## Parameter range

The bus coupler operating parameters are displayed and loaded using the P9000 operating program. These include

- the DSfG address
- the stream number
- the interface parameters

