

Safety Check Valve Series 585 Streamchek



PRODUCT INFORMATION

**Serving the Gas Industry
Worldwide**



by Honeywell

SAFETY CHECK VALVE SERIES 585 STREAMCHEK

Introduction

- The Series 585 is a high capacity, self-acting, tight shut-off, Discriminatory Check Valve for fitting between flanges, inside bolt circle, in horizontal pipe.

Application

- The valve is primarily intended for use in conjunction with safety cut-off valves (slamshut) in transmission systems pressure reduction stations. Its purpose is to automatically discriminate between faulty or healthy pressure reduction lines, identifying and initiating the isolation of a faulty (excess throughput) regulator, whilst protecting a healthy regulator against inadvertent shut-off.
- The valve may also be used as a conventional check valve in applications requiring the prevention of reverse gas flow. It is suitable for fitting between flanges to PN16: BS EN 1092-2:1997, Class 150, 300 and 600* ASA/ANSI B16.5.

* Excluding sizes 500 and 600mm

Size Range

80mm, 100mm, 150mm, 200mm, 250mm, 300mm, 350mm, 400mm, 450mm, 500mm and 600mm.

| MATERIALS OF CONSTRUCTION | |
|---------------------------|---|
| Body & Door | Plated Carbon Steel: BS. 1501 - 161 - 430B |
| 'O' Ring | High Nitrile Rubber |
| Spindle | Stainless Steel: BS.970 Pt. 4 416 S21. Cond. T |
| Bearing Plugs | Stainless Steel: BS.970 Pt. 4 416 S21. |
| Fastenings | H.T.S. Grade 12.9 |

| SERVICE CONDITIONS | |
|--|--|
| Maximum Working Pressure: PN16: BS EN1092-2:1997 | 16 barg (232 psig) |
| Class 150 | 19 barg (275 psig) |
| Class 300 | 50 barg (725 psig) |
| Class 600 | 100 barg (1450 psig) |
| Reverse Pressure Differential: | |
| Standard Model | 7 barg (101.5 psig) |
| Low Differential Model: Sizes 300, 350, 400, 450 & 500mm | 1 barg (14.5 psig) |
| 600mm | 0.35 barg (5 psig) |
| Temperature Range: | -20°C to +60°C |
| Medium: | Natural and manufactured gases of non-aggressive nature. |

Installation

- Suitable for mounting in horizontal mains only. To be installed with body tapping (eye bolt) to the top centre and nameplate arrow pointing in the direction of gas flow.
- Pipe flanges must be within 3° from vertical, otherwise closing efficiency or ΔP rating will be adversely affected. Care must be taken to ensure clearance in the downstream main and that the flange joint does not interfere with the valve door movement.

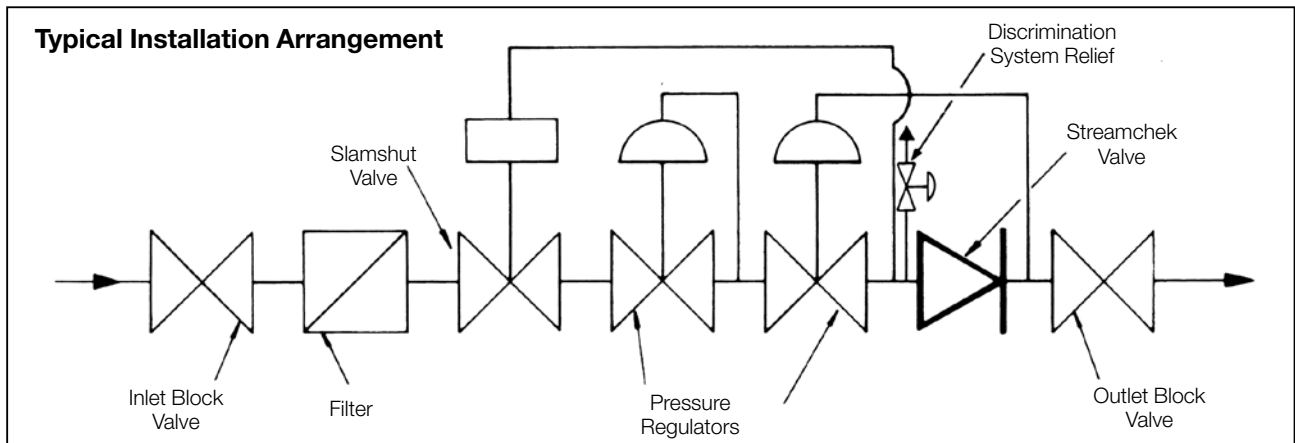

SAFETY CHECK VALVE SERIES 585 STREAMCHEK

Dimensions and Performance Data

Capacity Calculation

To calculate the gas carrying capacity of a given size of valve, firstly determine the ratio of the allowable ΔP against line pressure (absolute) to obtain pressure reduction factor 'K' from the graph. Then apply this, with flow coefficient C_v given in the table (see Note 1) in the relevant two formulae:

Where, P_i = Line pressure (absolute).
 Q (Sm^3/Hr) = $11.66 \times C_v \times K \times P_i$ (bar Abs.)
 Q (s.c.f.h.) = $28.4 \times C_v \times K \times P_i$ (psi Abs.)

Note 1

The C_v values given assume a wide-open valve absorbing a ΔP greater than 17.5 mbarg (7"wg), for lower ΔP values, multiply C_v by the respective factor as follows:

| ΔP mbar (ins wg) | Factor |
|--------------------------|--------|
| 0.75 (0.3) | 0.033 |
| 1.25 (0.5) | 0.08 |
| 2.5 (1.0) | 0.27 |
| 7.5 (3.0) | 0.75 |
| 12.5 (5.0) | 0.92 |

Example:

Valve Size: 250mm
 Inlet Pressure: 14 barg (203 psig)
 Allowable pressure drop: 0.3 barg (4.35 psig)
 $\Delta P/P_i \text{ abs} = 0.02$,
 therefore from graph, $K = 0.37$
 $Q = 11.08 \times 1722 \times 0.37 \times 15.01 = 105,963 \text{ sm}^3/\text{hr}$
OR,
 $Q = 26.98 \times 1722 \times 0.37 \times 217.7 = 3,742,271 \text{ s.c.f.h.}$

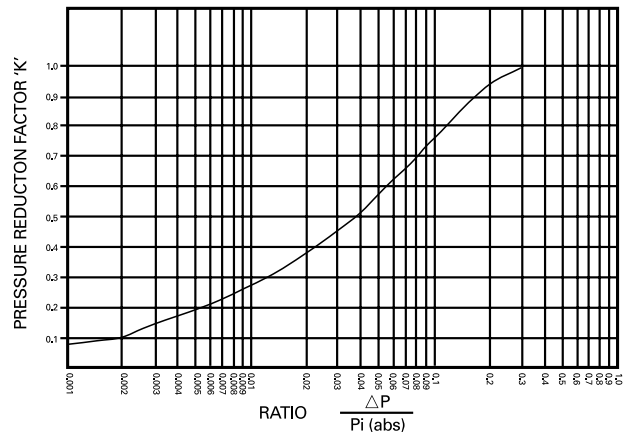

C_v Flow Coefficients:

| Size | 80 | 100 | 150 | 200 | 250 | 300 | 350 | 400 | 450 | 500 | 600 |
|-------|-----|-----|-----|------|------|------|------|------|------|------|------|
| C_v | 155 | 275 | 620 | 1102 | 1722 | 2480 | 3375 | 4408 | 5580 | 6888 | 9920 |

Types of Gases:

The capacities calculated are given in terms of natural gas SG 0.6. For all other gases multiply by the following correction factor:

$$\sqrt{\frac{0.6}{\text{SG of gas handled}}}$$

Dimensions & Weights

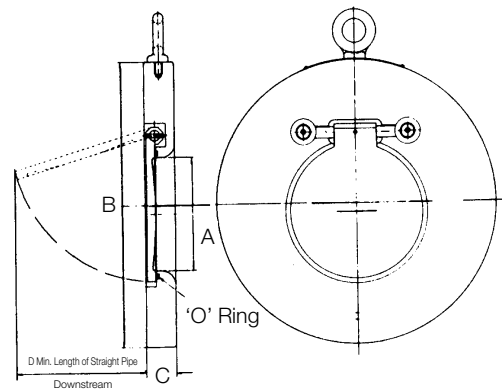

| PERFORMANCE DATA | | | | | | | | | | | | | | |
|------------------|-----|------|----------|----------|----------|------|----------|----------|----------|-----|-----------|----------|----------|----------|
| Size | A | B | | | | C | | | | D | Weight kg | | | |
| | | PN16 | Ansi 150 | Ansi 300 | Ansi 600 | PN16 | Ansi 150 | Ansi 300 | Ansi 600 | | PN16 | Ansi 150 | Ansi 300 | Ansi 600 |
| 80 | 46 | 136 | 136 | 148 | 148 | 19.1 | 19.1 | 19.1 | 19.1 | 60 | 1.85 | 1.85 | 2.4 | 2.4 |
| 100 | 58 | 173 | 173 | 178 | 191 | 19.1 | 19.1 | 19.1 | 19.1 | 70 | 2.4 | 2.4 | 3.25 | 3.25 |
| 150 | 105 | 219 | 219 | 248 | 264 | 23.5 | 23.5 | 22.2 | 28.6 | 136 | 5.5 | 5.5 | 7.5 | 10.5 |
| 200 | 150 | 275 | 275 | 306 | 320 | 28.6 | 28.6 | 28.6 | 38.1 | 183 | 10.5 | 10.5 | 13.5 | 19.5 |
| 250 | 190 | 331 | 339 | 360 | 398 | 38.1 | 38.1 | 38.1 | 57.2 | 229 | 19.5 | 20.5 | 24.0 | 45.0 |
| 300 | 225 | 386 | 408 | 421 | 455 | 38.1 | 38.1 | 50.8 | 60.3 | 273 | 25.5 | 30.0 | 42.0 | 60.5 |
| 350 | 250 | 446 | 446 | 485 | 490 | 44.5 | 44.5 | 50.8 | 66.7 | 300 | 41.0 | 41.0 | 57.5 | 76.5 |
| 400 | 294 | 498 | 514 | 540 | 565 | 50.8 | 50.8 | 50.8 | 73.0 | 350 | 56.5 | 61.5 | 70.0 | 110.0 |
| 450 | 328 | 558 | 549 | 595 | 610 | 60.3 | 60.3 | 76.2 | 82.6 | 387 | 85.0 | 81.0 | 125.0 | 142.0 |
| 500 | 366 | 618 | 605 | 652 | - | 63.5 | 63.5 | 82.6 | - | 435 | - | - | - | - |
| 600 | 455 | 728 | 714 | 772 | - | 66.7 | 66.7 | 82.6 | - | 524 | - | - | - | - |

All dimensions in mm

For More Information

To learn more about RMG's advanced gas solutions, contact your RMG account manager or visit www.rmg.com

GERMANY

Honeywell Process Solutions

RMG Regel + Messtechnik GmbH
Osterholzstrasse 45
34123 Kassel, Germany
Tel: +49 (0)561 5007-0
Fax: +49 (0)561 5007-107

Honeywell Process Solutions

RMG Messtechnik GmbH
Otto-Hahn-Strasse 5
35510 Butzbach, Germany
Tel: +49 (0)6033 897-0
Fax: +49 (0)6033 897-130

Honeywell Process Solutions

RMG Gaselan Regel + Messtechnik GmbH
Julius-Pintsch-Ring 3
15517 Fürstenwalde, Germany
Tel: +49 (0)3361 356-60
Fax: +49 (0)3361 356-836

Honeywell Process Solutions

WÄGA Wärme-Gastechnik GmbH
Osterholzstrasse 45
34123 Kassel, Germany
Tel: +49 (0)561 5007-0
Fax: +49 (0)561 5007-207

POLAND

Honeywell Process Solutions
Gazomet Sp. z o.o.
ul. Sarnowska 2
63-900 Rawicz, Poland
Tel: +48 (0)65 5462401
Fax: +48 (0)65 5462408

ENGLAND

Honeywell Process Solutions

Bryan Donkin RMG Gas Controls Ltd.
Enterprise Drive, Holmewood
Chesterfield S42 5UZ, England
Tel: +44 (0)1246 501-501
Fax: +44 (0)1246 501-500

CANADA

Honeywell Process Solutions

Bryan Donkin RMG Canada Ltd.
50 Clarke Street South, Woodstock
Ontario N4S 0A8, Canada
Tel: +1 (0)519 5398531
Fax: +1 (0)519 5373339

USA

Honeywell Process Solutions

Mercury Instruments LLC
3940 Virginia Avenue
Cincinnati, Ohio 45227, USA
Tel: +1 (0)513 272-1111
Fax: +1 (0)513 272-0211

TURKEY

Honeywell Process Solutions

RMG GAZ KONT. SIS. ITH. IHR. LTD. STI.
Birlik Sanayi Sitesi, 6.
Cd. 62. Sokak No: 7-8-9-10
TR - Sasmaz / Ankara, Turkey
Tel: +90 (0)312 27810-80
Fax: +90 (0)312 27828-23