

Safety Check Valve Series 580/581 Waferchek



PRODUCT INFORMATION

**Serving the Gas Industry
Worldwide**



SAFETY CHECK VALVE SERIES 580/581 WAFERCHEK

Introduction

- The Series 580 and 581 is a wafer type, self acting offset disc check valve, designed for fitting between flanges.
- The Series 581 is specifically designed for use with below ground Gas Control Module installations.

Application

- The valve is primarily intended for use in conjunction with safety cut-off valves (slamshut) in gas pressure regulator installations feeding a common district network or industrial premises. Its purpose is to automatically identify and initiate the isolation of a faulty (excess throughput) regulator, whilst protecting a healthy regulator against inadvertent shut-off.
- The regulator locations may be adjacent, as a twin or multiple streams, or in widely separated single installations, since the incorporation of a Waferchek valve at each individual regulator outlet renders each installation self-contained. This enables a common pressure setting to be adopted on all the slamshut valves incorporated in the same gas supply network.
- The valve may also be used as a conventional check valve in applications requiring the prevention of reverse mass flow, but where a small amount of reverse leakage can be tolerated. Not suitable for use on fan blower, gas booster etc.

SERVICE CONDITIONS	
Maximum Working Pressure:	7 barg (100 psig)
Constructional Strength:	19 barg (275 psig)
Reverse Pressure Differential:	
Series 580	1 barg (14.5 psig)
Series 581	0.34 barg (5 psig)
Temperature Range:	-20°C to +60°C
Medium:	Natural and manufactured gases of non-aggressive nature.

SIZE RANGE	
Series 580	Series 581
50mm, 80mm, 100mm 150mm, 200mm 250mm, 300mm	200mm

Installation

- Suitable for mounting in horizontal mains only. To be installed with body tapping (hook bolt) to the top centre and nameplate arrow pointing in the direction of gas flow.
- The standard unit locates centrally within the bolt circle of flanges to PN16:BS EN 1092-2:1997, care to be taken to ensure clearance in the downstream main and that the flange joint does not interfere with the valve door movement.

Pressure Loss

Due to the light door construction, the pressure drop is very low, e.g., 1.25mbarg (0.5" wg), when the door is in the fully open position after which Square Law Flow (approx.) applies. At STP conditions the pressure drop may be obtained directly from the graph.

At other conditions of pressure the following formula applies:

Pressure drop in mbarg or Pressure drop in ins. w.g.

$$H_m \times \frac{1.013}{P_u} \text{ m bar} \qquad H_i \times \frac{14.7}{P_u} \text{ in. w.g.}$$

Where H_m and H_i = pressure drop from graph

P_u = Upstream pressure, bar abs, or p.s.i.a (dependent upon formula used)

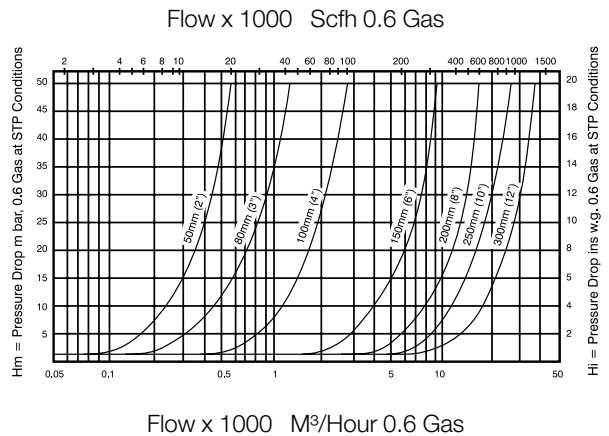

SAFETY CHECK VALVE SERIES 580/581 WAFERCHEK

Dimensions and Performance Data

Leakage

The Waferchek valve does not have a tight seal and a small amount of reverse leakage will take place, this will not exceed the flows given in the table below for reverse pressure differential of up to 1 barg (14.5 psig) for the Series 580 and 0.34 barg (5 psig) for the Series 581.

Valve Size

mm	50	80	100	150	200	250	300
ins	2	3	4	6	8	10	12

Leakage Gas (SG 0.6)

Sm ³ /hr	10.6	14.2	19.8	22.7	28.3	31.2	31.2
scfh	375	500	700	800	1000	1100	1100

DIMENSIONS AND WEIGHTS						
Size	A	B	C	D	E	Wt.kg
50	43.4	50	106	19	21	0.9
80	66.4	80	140	19	37	1.35
100	86.7	100	161	22	50	2.35
150	136.4	150	216	22	83	3.62
200	181.4	200	273	22	113	5.45
250	226.4	250	330	35	140	26.5
300	271.4	300	384	35	172	33.5

All dimensions in mm

Note: A hook bolt is provided to facilitate installation

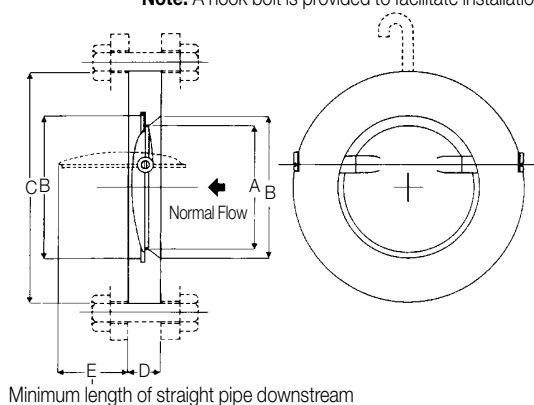

MATERIALS OF CONSTRUCTION	
Component	Material
Body	Carbon Steel
Door	580 - Aluminium 581 - Nylon
Spindle	Stainless Steel
Spindle Bearings	Ceramic PTFE or Phosphor Bronze
Door Seal	Nitrile Rubber

Testing (for freedom of operation)

Facilities are provided for testing the free movement of the valve in situ. With the pipe unpressurised, remove one end plug, insert screwdriver to engage slot in the end of the door spindle. The door should rotate through an angle of 60° minimum and return freely to the vertical seating position.

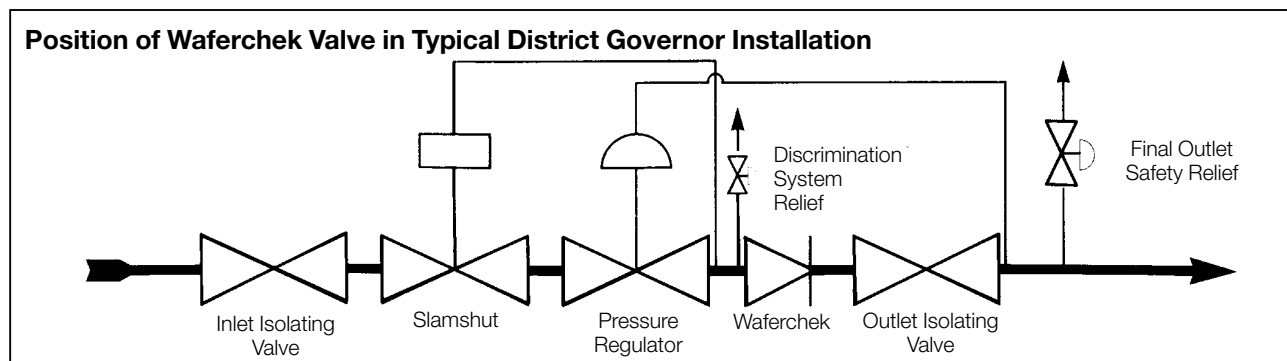
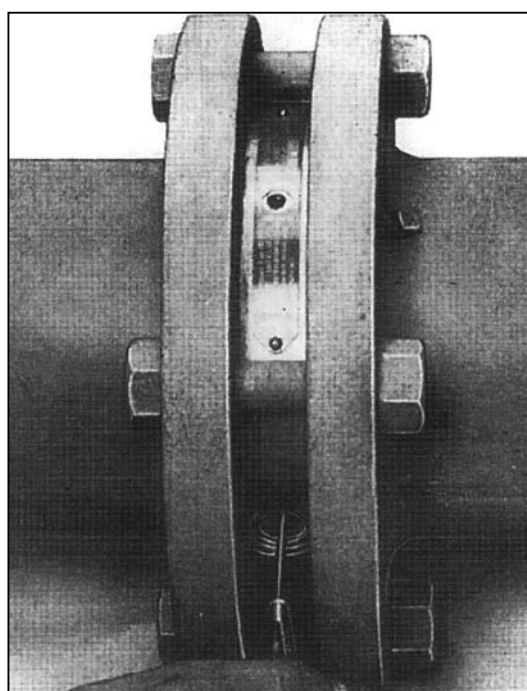

For More Information

To learn more about RMG's advanced gas solutions, contact your RMG account manager or visit www.rmg.com

GERMANY

Honeywell Process Solutions

RMG Regel + Messtechnik GmbH
Osterholzstrasse 45
34123 Kassel, Germany
Tel: +49 (0)561 5007-0
Fax: +49 (0)561 5007-107

Honeywell Process Solutions

RMG Messtechnik GmbH
Otto-Hahn-Strasse 5
35510 Butzbach, Germany
Tel: +49 (0)6033 897-0
Fax: +49 (0)6033 897-130

Honeywell Process Solutions

RMG Gaselan Regel + Messtechnik GmbH
Julius-Pintsch-Ring 3
15517 Fürstenwalde, Germany
Tel: +49 (0)3361 356-60
Fax: +49 (0)3361 356-836

Honeywell Process Solutions

WÄGA Wärme-Gastechnik GmbH
Osterholzstrasse 45
34123 Kassel, Germany
Tel: +49 (0)561 5007-0
Fax: +49 (0)561 5007-207

POLAND

Honeywell Process Solutions
Gazomet Sp. z o.o.
ul. Sarnowska 2
63-900 Rawicz, Poland
Tel: +48 (0)65 5462401
Fax: +48 (0)65 5462408

ENGLAND

Honeywell Process Solutions

Bryan Donkin RMG Gas Controls Ltd.
Enterprise Drive, Holmewood
Chesterfield S42 5UZ, England
Tel: +44 (0)1246 501-501
Fax: +44 (0)1246 501-500

CANADA

Honeywell Process Solutions

Bryan Donkin RMG Canada Ltd.
50 Clarke Street South, Woodstock
Ontario N4S 0A8, Canada
Tel: +1 (0)519 5398531
Fax: +1 (0)519 5373339

USA

Honeywell Process Solutions

Mercury Instruments LLC
3940 Virginia Avenue
Cincinnati, Ohio 45227, USA
Tel: +1 (0)513 272-1111
Fax: +1 (0)513 272-0211

TURKEY

Honeywell Process Solutions

RMG GAZ KONT. SIS. ITH. IHR. LTD. STI.
Birlik Sanayi Sitesi, 6.
Cd. 62. Sokak No: 7-8-9-10
TR - Sasmaz / Ankara, Turkey
Tel: +90 (0)312 27810-80
Fax: +90 (0)312 27828-23

