

Safety Cut-Off Valve Series 305



PRODUCT INFORMATION

**Serving the Gas Industry
Worldwide**



SAFETY CUT-OFF VALVE SERIES 305

Introduction, Application, Features, Technical Data

Introduction

- The Series 305 is a safety cut-off valve of single in line orifice design, overpressure operated, with external control line connection, manual reset and pressure balancing bypass. Completely self-acting and requires no separate power source to close the valve.

Application

- Designed to safeguard gas distribution systems, normally installed upstream of the pressure regulator with the external control line piped to the downstream of the regulator, closing automatically in the event of an overpressure condition. After closure, the valve must be manually reset to the open position after normal pressure conditions have been restored by use of the manual bypass valve.

Installation

Sizes up to and including DN 100 can be installed in both the horizontal and vertical positions.

The DN 150 and DN 200 sized units can only be installed in the horizontal position with the spring housing pointing vertically upwards.

Options

Can be supplied with proximity sensor system to initiate 'valve-open' or 'valve-closed' indicator on remote panel.

Features

- Helical torsion spring secures valve door in closed position.
- Fully enclosed valve position indicator - colour coded to show valve status.
- Specially designed spindle and seal between trigger mechanism and diaphragm actuator practically eliminates effect of inlet pressure variation on trip set point.
- Integral push button pressure equalising valve.
- Low Pressure Loss.
- Manual Reset.
- V9 Approval

Size Range

*DN 50
DN 80
DN 100
DN150
DN 200

*DN 50 - Flanged short face to face (SFF) model available on request

temperature Range

-20°C to +60°C

Connections

Flanged connections to PN16: BS EN 1092-2:1997

ANSI B16.5 Class 150 (19barg)

External Control Line connection: Rc 1/4

Diaphragm breather connection Rc 1/8

SELECTION GUIDE

Series 305-LP	Range: 0.025 to 0.75 bar g (0.4 to 11 psig)
Series 305-MP	Range: 0.3 to 2.75 bar g (4 to 40 psig)
Series 305-IP	Range: 2.5 to 7.0 bar g (36 to 101 psig)

Pressure Rating

16 barg (232 psig) - Ductile Iron Body

19 barg - (275 psig) Ductile Iron Construction

SPRING SELECTION						
Model	Spring		Trip Pressure Range			
	Number	Colour	Minimum bar g	Maximum bar g	Minimum psi g	Maximum psi g
305-LP Low Pressure	*1200	Silver	0.025	0.05	0.4	0.7
	495	Orange	0.045	0.125	0.6	1.8
	835	Blue	0.112	0.25	1.6	3.6
	839	Grey	0.235	0.35	3.4	5.0
	1054	Red/White	0.28	0.55	4.0	8.0
	1059	Red/Yellow	0.5	0.75	7.0	11.0
305-MP Medium Pressure	495	Orange	0.3	0.4	4.0	6.0
	835	Blue	0.36	0.9	5.0	13.0
	839	Grey	0.8	1.35	11.5	20.0
	1054	Red/White	1.12	2.25	16.0	32.5
	1059	Red/Yellow	1.95	2.75	28.0	40.0
305-IP Intermediate Pressure	1077	Yellow	2.5	3.3	36.0	48.0
	1078	Green	3.1	4.0	45.0	58.0
	1079	White	3.8	5.0	55.0	72.0
	1080	Red	4.8	6.0	70.0	87.0
	1300	Self	5.5	7.0	80.0	101.0

*Non GIS/V9-1 Spring Range

Pressure Loss

The Series 305 is designed for minimal pressure loss (Δp)

$$P_i - P_o = P_i - \frac{P_i - \sqrt{P_i^2 - 4(Q/K)^2}}{2} \text{ bar}$$

Where:

Q = Valve flow M³/Hr (SG 0.6)

P_i = Inlet pressure bar (abs)

P_o = Outlet Pressure bar (abs)

K = Flow Constant

(abs) = Absolute pressure 1.01325

When sizing valves in accordance with GIS/V9-1 the maximum recommended gas velocity through the safety cut-off valve should not exceed 80 m/sec, (262 ft./sec).

Consideration given to higher gas velocities on request - please contact BD-RMG for details.

FLOW CONSTANT	
Valve Size	Flow Constant
DN 50	3860
DN 80	7861
DN 100	16302
DN 150	49780
DN 200	78818

Conversion Factors

The pressure loss calculation is given in terms of natural gas SG 0.6. For all other gases multiply by the following correction factor:

$$\sqrt{\frac{0.6}{\text{SG of gas handled}}}$$

Conversion to ft³/hr - multiply by 35.3

SAFETY CUT-OFF VALVE SERIES 305

Dimensions & Weights, Material of Construction

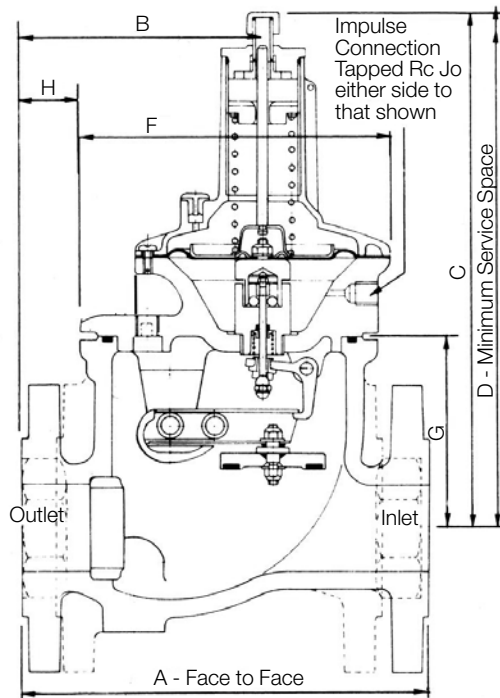

Dimension E centre line of valve to maximum extent of by-pass mechanism positioned a side of body.

SERVICE CONDITIONS	
Component	Material
Body and top cover	Ductile Iron to BS EN 1563 Grade: EN-GJS-400-18
Spring housing and cap (Dependent on model)	Aluminium - BS.1490 Grade LM24 or Ductile Iron to BS EN 1563 Grade: EN-GJS-400-18
Ball, Trigger assembly and operating spindles	Stainless Steel: BS.970 Grade 416S21
Valve Orifice	Stainless Steel: BS.970 Grade 316S21
Seal retainer, reset and bypass housing	Brass: BS.2874 Grade CZ 121
Diaphragm	Nylon reinforced nitrile
Diaphragm plate	Mild Steel: BS.1449 Grade D1 zinc plated
'O' Rings	Nitrile
Main spring	Spring Steel: BS.1726 oiled finished
Bypass spring, door spring and trigger spring	Stainless Steel: BS.970 Grade 302S25
Reset spring	Music Wire: BS5216 Grade M5
Valve door	Aluminium: BS 1474 Grade HE 30TF with polyurethane seat 70/75 shore hardness

DIMENSIONS											
Size	Connections	Dimensions (mm)								Degrees	Weight Kg
		A	B	C	D	E	F	G	H		
DN 50	Flanged	230	136	295	400	125	168	110	33	-	21
DN 50	Flanged (S.F.F.)	184	116	295	400	125	168	110	13	-	18
DN 80	Flanged	276	169	310	430	135	208	126	38	-	29
DN 100	Flanged	292	169	320	455	135	208	137	38	-	33
DN 150	Flanged	381	203	370	505	206	273	178	67	30	75
DN 200	Flanged	457	248	405	540	234	330	216	83	40	108

SAFETY CUT-OFF VALVE SERIES 305

Sectional Arrangement

4

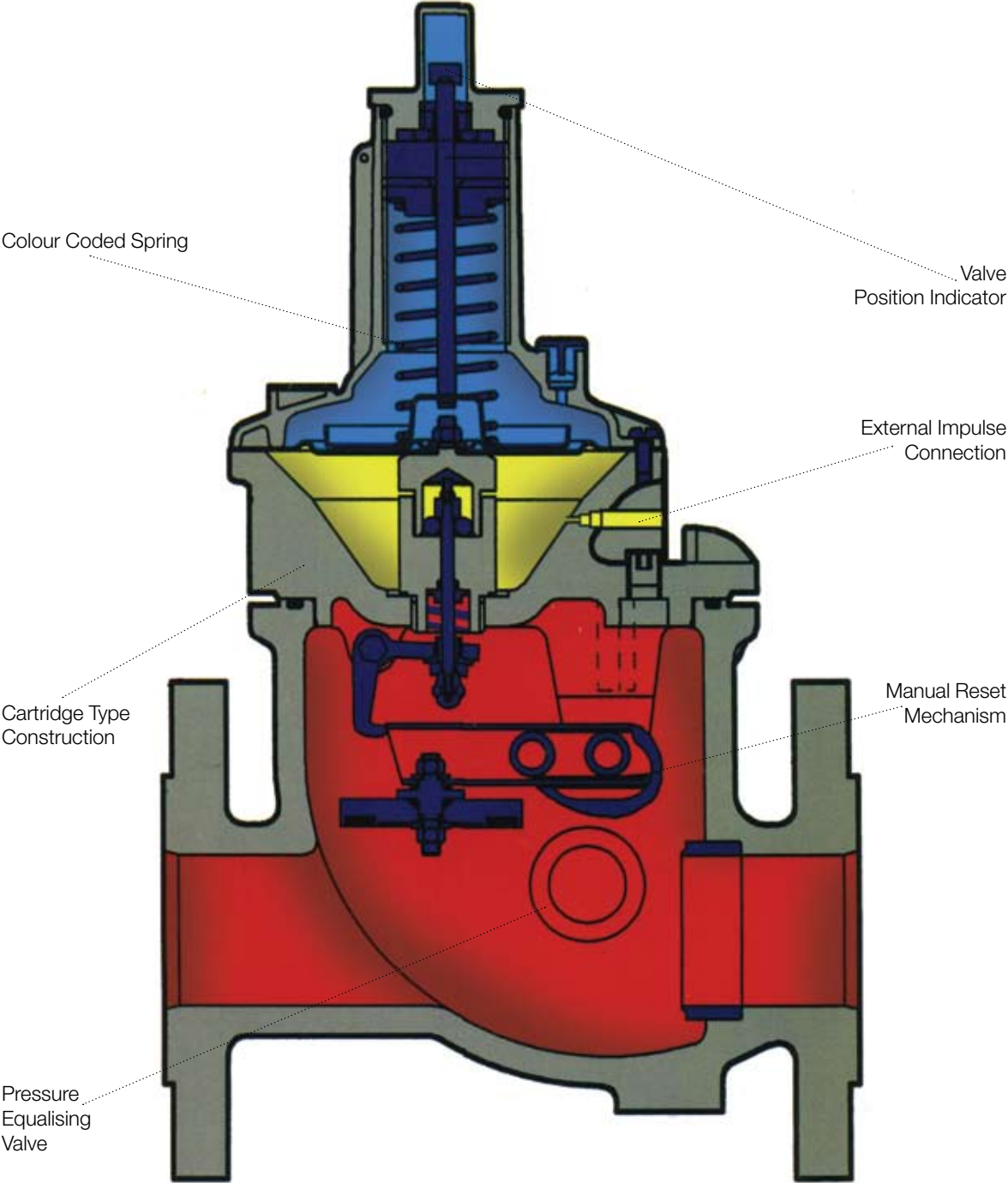

 Inlet Pressure

 Outlet Pressure

 Atmospheric Pressure

For More Information

To learn more about RMG's advanced gas solutions, contact your RMG account manager or visit www.rmg.com

GERMANY

Honeywell Process Solutions

RMG Regel + Messtechnik GmbH
Osterholzstrasse 45
34123 Kassel, Germany
Tel: +49 (0)561 5007-0
Fax: +49 (0)561 5007-107

Honeywell Process Solutions

RMG Messtechnik GmbH
Otto-Hahn-Strasse 5
35510 Butzbach, Germany
Tel: +49 (0)6033 897-0
Fax: +49 (0)6033 897-130

Honeywell Process Solutions

RMG Gaselan Regel + Messtechnik GmbH
Julius-Pintsch-Ring 3
15517 Fürstenwalde, Germany
Tel: +49 (0)3361 356-60
Fax: +49 (0)3361 356-836

Honeywell Process Solutions

WÄGA Wärme-Gastechnik GmbH
Osterholzstrasse 45
34123 Kassel, Germany
Tel: +49 (0)561 5007-0
Fax: +49 (0)561 5007-207

POLAND

Honeywell Process Solutions
Gazomet Sp. z o.o.
ul. Sarnowska 2
63-900 Rawicz, Poland
Tel: +48 (0)65 5462401
Fax: +48 (0)65 5462408

ENGLAND

Honeywell Process Solutions

Bryan Donkin RMG Gas Controls Ltd.
Enterprise Drive, Holmewood
Chesterfield S42 5UZ, England
Tel: +44 (0)1246 501-501
Fax: +44 (0)1246 501-500

CANADA

Honeywell Process Solutions

Bryan Donkin RMG Canada Ltd.
50 Clarke Street South, Woodstock
Ontario N4S 0A8, Canada
Tel: +1 (0)519 5398531
Fax: +1 (0)519 5373339

USA

Honeywell Process Solutions

Mercury Instruments LLC
3940 Virginia Avenue
Cincinnati, Ohio 45227, USA
Tel: +1 (0)513 272-1111
Fax: +1 (0)513 272-0211

TURKEY

Honeywell Process Solutions

RMG GAZ KONT. SIS. ITH. IHR. LTD. STI.
Birlik Sanayi Sitesi, 6.
Cd. 62. Sokak No: 7-8-9-10
TR - Sasmaz / Ankara, Turkey
Tel: +90 (0)312 27810-80
Fax: +90 (0)312 27828-23