

Flow Control Valve RMG 530



PRODUCT INFORMATION

**Serving the Gas Industry
Worldwide**



Flow Control Valve RMG 530

Application, advantages, technical Data

Advantages

- electrically-driven main valve
- high flow rate coefficients
- up to DN 100/200 with incorporated SAV
- valve sleeve with pressure compensation
- noise reducing outlet duct as a standard feature
- characteristic curve: equal percentage (hyperbolic) and linear
- sensitive PI regulation
- approved by DVGW

Application

- for flow and pressure control
- suitable for natural gas and all non-corrosive gases

TECHNICAL DATA	
Main Valve	
max. inlet pressure	100 bar (DN 250/250 and DN 300/300, 250 bar)
size (other sizes upon request)	- body with flow diversion: DN 50/100, DN 80/150, DN 100/200, DN 150/300, - body with axial flow: DN 200/300, DN 250/250, DN 300/300, DN 400/600
connection	for p_{\max} 250 bar, flanged according to ANSI 1500 RJ, ANSI 900 RJ in DN 250/250 and DN 300/300, otherwise flanged to ANSI 600 RF and ANSI 900 RJ
valve sleeve	- with pressure compensation - with ceramic coating for less friction and optimal accuracy
bubble-tight shut-off on zero flow	rubber sealing
noise reducing outlet	standard feature
Actuator	
voltage	230V, 50 Hz or 400V, 50 Hz (DN 200 and larger: only 400V, 50 Hz)
power supply	0,5 - 1,5 kW (depending on size)
explosion protection	E Ex edib II CT4
power transmission	gearbox
adjusting time	between 68 - 620 s depending on task
stroke limiting switches	standard feature
torque limiting switches	standard feature
electric control	with frequency converter
valve position indicator	potentiometer 5 k Ω or 0/4 - 20 mA signal

FLOW RATE COEFFICIENT KG IN M ³ /H (FOR NATURAL GAS, ρ _N = 0,83 KG/M ³)								
inlet/outlet	50/100*	80/150*	100/200*	150/300	200/300	250/250 PN250	300/300 PN250	400/600 PN250
KG-value (without SAV)	2000	5100	8000	15000	23000	24000	26000	80000
KG-value (with SAV)	1300	4600	7200	-	-	-	-	-

* additional use of a noise reducing outlet may decrease the KG-value by 10%.

APPROVED BY DVGW	
DVGW-reg.-no.:	DG4301AL0007

ADJUSTABLE RANGES OF SAV-MEASURING UNITS TO BE COMBINED WITH INTEGRATED SAFETY CUT-OFF VALVE (ONLY APPLICABLE FOR DN 50/100 TO DN 100/200)								
actuator	setpoint spring			overpressure release		underpressure release		response precision category**
	no.	colour	wire dia. in mm	setting range	minimum differential between response pressure and normal service pressure*	setting range	minimum differential between response pressure and normal service pressure*	
				W _{HO} (bar)	Δp (bar)	W _{HU} (bar)	Δp (bar)	
K10a	1	yellow	2,5	0,050 ... 0,100	0,050			10/5
	2	bright red	3,2	0,100 ... 0,250	0,050			10/5
	3	dark red	3,6	0,200 ... 0,500	0,100			5/2,5
	4	white	4,75	0,400 ... 1,500	0,250			5/2,5
	5	light blue	1,1			0,010 ... 0,015	0,012	15
	6	white	1,2			0,014 ... 0,040	0,030	15/5
	7	black	1,4			0,035 ... 0,120	0,060	5
K11a/1	1	bright red	3,2	0,400 ... 0,800	0,100			10/5
	2	dark red	3,6	0,600 ... 1,600	0,200			10/5
	3	white	4,75	2,500 ... 8,000	0,300			5/2,5
	4	light blue	1,1			0,060 ... 0,150	0,050	15/5
	5	black	1,4			0,120 ... 0,400	0,080	5
	6	red	2,25			0,350 ... 1,000	0,100	5
K11a/2	2	white	4,75	2,500 ... 8,000	0,500			10/5
	6	red	2,25			0,900 ... 2,200	0,400	15/5
K16	0	blue	3,2	0,800 ... 1,500	0,100			2,5
	1	black	4,5	1,000 ... 5,000	0,200			2,5/1
	2	grey	5,0	2,000 ... 10,00	0,400			1
	3	brown	6,3	5,000 ... 20,00	0,800			1
	4	red	7,0	10,00 ... 40,00	1,200			1
K17	2	grey	5,0			2,000 ... 10,00	0,400	5
	3	brown	6,3			5,000 ... 20,00	0,800	5
	4	red	7,0			10,00 ... 40,00	1,200	5
K18	1		9,0	20,00 ... 90,00	1,500			1

*) note: if actuators are used with both overpressure and underpressure release, then the min. gap between the two setpoints has to 10 % larger than the sum of the two differential values (Δp_O + Δp_U).

**) The higher response precision category is valid for the first half, the lower response precision category is valid for the second half of the setting range.

Flow Control Valve RMG 530

Design and function

The flow control valve RMG 530 works combined with electronic flow- or pressure-controlling regulating systems. It is used specially where great flow values have to be achieved at minimal pressure differentials. Two different designs are used:

main valve DN 50/100 up to DN 150/300

For size up to DN 100/200 two different body versions are available:

- body without safety shut-off device (body of RMG 502).
- body with integrated safety shut-off device (body of RMG 503).

The electric actuator mounted on top of the main valve pushes the valve sleeve into the required position via a threaded axle. For sizes DN 80/100 and DN 100/200 identical actuators and valve sleeve parts are used. The max. valve sleeve opening corresponds to the inlet diameter. Rubber sealings guarantee a bubble-tight shut-off when the valve is closed.

The special arrangement of the expansion bore holes provide a equal percentage (hyperbolic) and linear characteristic curve. The bore holes also guarantee a noise reduction of up to 15 dB(A) compared to standard valve arrangements with valve plate and valve seat. Further noise reducing elements can be added, thus reducing the noise level up to 30 dB(A). Please note that these elements also reduce the flow rate (KG-value) by 10%.

The main valve is easily maintained as only the valve sleeve and the expansion sleeve have to be removed from the body.

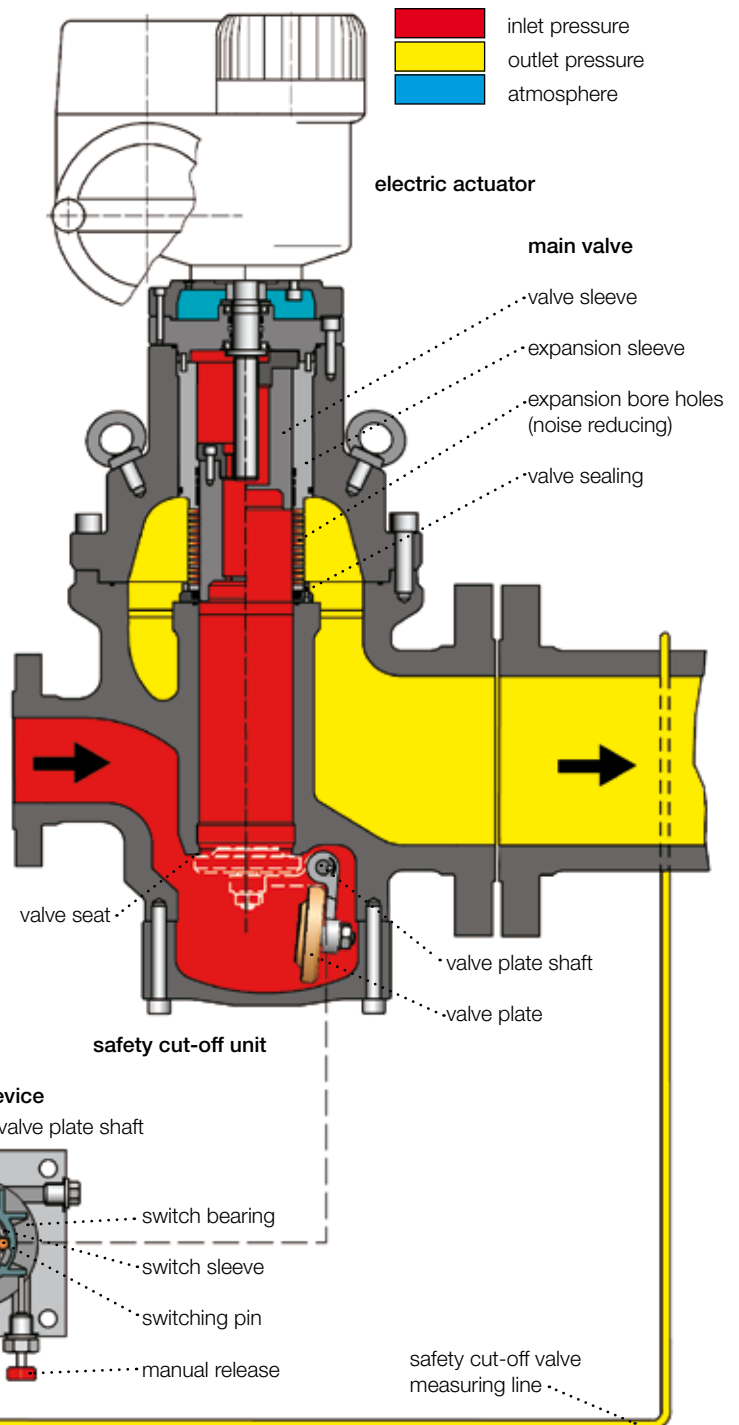

main valve DN 200/300 to DN 400/600

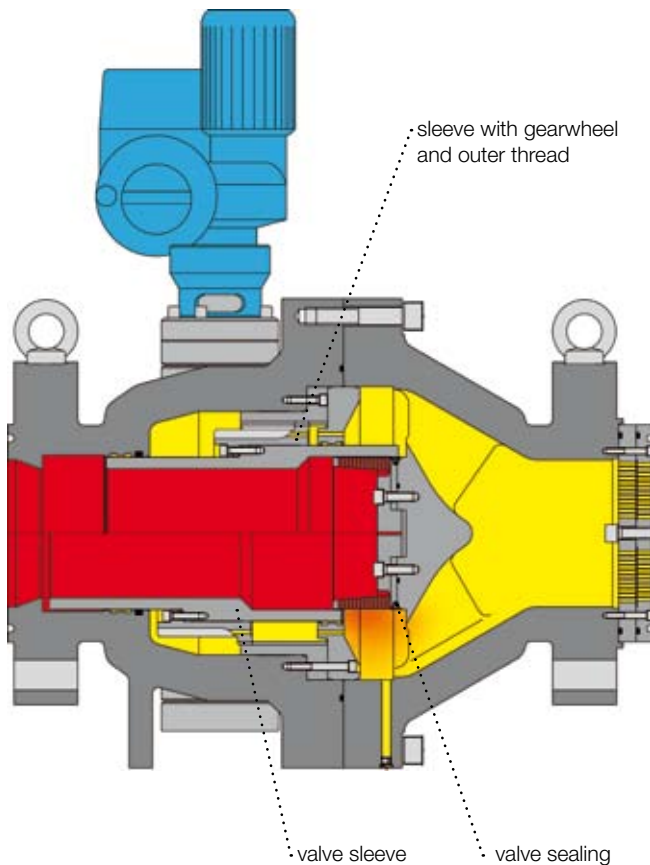

The flow control valves starting from inlet pipe dia. DN 200 and upward are designed for axial flow, and therefore a safety shut-off valve cannot be included. The proven valve sleeve system is used, thus enabling complete inlet and outlet pressure compensation. The valve sealing situated in the valve cone guarantees bubble-tight shut-off of the device.

The electric actuator positions the valve sleeve by turning a worm wheel which then turns a sleeve with gearwheel fixed on to the valve sleeve. As the gearwheel sleeve also runs in a threaded outer ring, the rotation of the valve sleeve moves the valve sleeve backward and forward.

The main valve has a integrated noise reducing outlet duct as standard. The principle of multiple expansions, the division of the gas stream and the local confinement of the complete expansion guarantee a noise level reduction of 20 dB(A) to 30 dB(A) compared to a standard valve fitted with valve plate and valve seat.

example: version DN 300/300 PN 250

actuator

Different actuator versions can be used: Up to inlet size DN 200 the RMG electronic systems need a 230 VAC power supply. Mechanical and electrical position indicators are a standard feature on all actuators. The customer may choose the service side of the main valve (right or left side when looking in flow direction). The hand-wheel can be used for manual movement of the valve sleeve.

The standard rotary actuators are steered by frequency converters. The advantage of frequency converters is that the turning speed can be varied and thus a much better positioning of the valve sleeve can be achieved compared to standard current switching systems. Together with the automation system Protronic 500 a complete package is available, which permanently adjusts to the prevailing demands. Especially in stations with high pressure differences at the flow control valve the RMG system can prove its superiority compared to classic designs.

The electronic RMG regulating systems are perfectly matched to the individual customer's demands. Experienced RMG engineers are at your service for enquiries and support (see also the RMG-leaflet „Automation Technology“).

Flow Control Valve RMG 530

Dimensions and weights

el. thrust drive

Schoppe & Faeser (S&F)

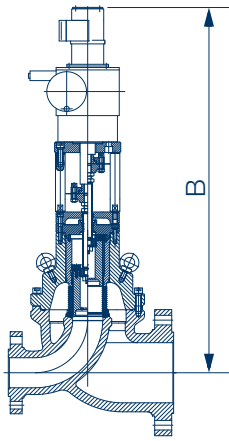

el. rotary drive

AUMA
EMG

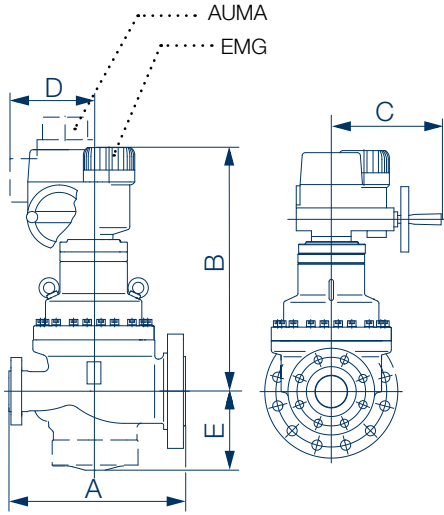

		DIMENSIONS IN MM			
		size			
		50/100	80/150	100/200	150/300
A		380	550	550	750
B	AUMA	655	720	720	1200
	EMG	695	760	760	1300
C	AUMA	260	260	260	260
	EMG	350	350	350	350
D	AUMA	285	285	285	285
E	m. SAV	170	170	200	-

el. rotary drive

EMG

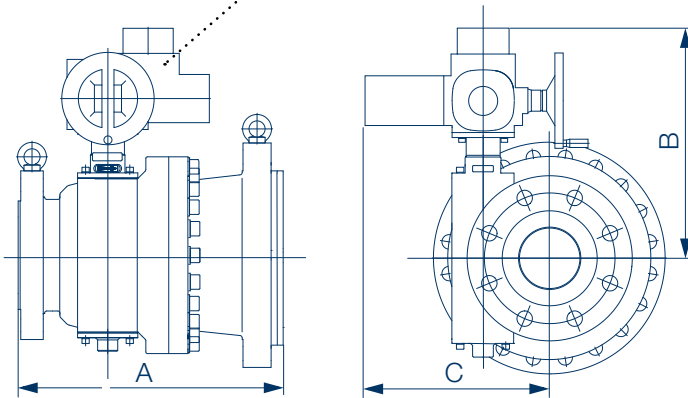

		DIMENSIONS IN MM				
		Nennweite				
		200/300	300/300	PN250 250/250	PN250 300/300	400/600
A		660	682	1100	1100	1350
B	AUMA	562	562			
	EMG	600	600	892	892	1230
C	AUMA	445	445			
	EMG	310	310	305	305	-

WEIGHTS								
inlet/outlet	50/100	80/150	100/200	200/300	PN250 250/250	300/300	PN250 300/300	400/600
appr. weight* in kg	140	250	270	530	1700	575	1750	2750

*) depending on special features

example

RMG 530 - 50 / 100 - 1 - R/L - K16 / E2 / F - So

MAIN VALVE		
size		
DN		
50/100		
80/150		
100/200		
150/300		
200/200		
200/300		
200/400		
250/250		
250/400		
300/300		
400/600		
ACTUATOR		
AUMA-motor	1	
EMG-motor	2	
S&F thrust torque (only up to DN 100/300)	3	
ELECTRICAL REGULATOR		
frequency converter	F	
SAFETY SHUT-OFF VALVE (SEE GENERAL DESCRIPTION 711.00)		
setting range in bar (only up to DN 100/200 incl.)		
overpressure release W_{do}	underpressure release W_{du}	actuator
0,1 ... 1,5	0,01 ... 0,12	K 10a
0,4 ... 4,5	0,06 ... 1,00	K 11a/1
2,5 ... 8,0	0,80 ... 2,20	K 11a/2
1,0 ... 40,0		K 16
	2,00 ... 40,00	K 17
20,0 ... 90,0		K 18
electro-magnetic release upon:		
current impulse	E 1	
power failure	E 2	
remote signalling of valve position „closed“		
	F	
SPECIAL FEATURE (TO BE SPECIFIED)		
	So	

For More Information

To learn more about RMG's advanced gas solutions, contact your RMG account manager or visit www.rmg.com

GERMANY

Honeywell Process Solutions

RMG Regel + Messtechnik GmbH
Osterholzstrasse 45
34123 Kassel, Deutschland
Tel: +49 (0)561 5007-0
Fax: +49 (0)561 5007-107

Honeywell Process Solutions

RMG Messtechnik GmbH
Otto-Hahn-Strasse 5
35510 Butzbach, Deutschland
Tel: +49 (0)6033 897-0
Fax: +49 (0)6033 897-130

Honeywell Process Solutions

RMG Gaselan Regel + Messtechnik GmbH
Julius-Pintsch-Ring 3
15517 Fürstenwalde, Deutschland
Tel: +49 (0)3361 356-60
Fax: +49 (0)3361 356-836

Honeywell Process Solutions

WÄGA Wärme-Gastechnik GmbH
Osterholzstrasse 45
34123 Kassel, Deutschland
Tel: +49 (0)561 5007-0
Fax: +49 (0)561 5007-207

POLAND

Honeywell Process Solutions

Gazomet Sp. z o.o.
ul. Sarnowska 2
63-900 Rawicz, Polen
Tel: +48 (0)65 5462401
Fax: +48 (0)65 5462408

ENGLAND

Honeywell Process Solutions

Bryan Donkin RMG Gas Controls Ltd.
Enterprise Drive, Holmewood
Chesterfield S42 5UZ, England
Tel: +44 (0)1246 501-501
Fax: +44 (0)1246 501-500

CANADA

Honeywell Process Solutions

Bryan Donkin RMG Canada Ltd.
50 Clarke Street South, Woodstock
Ontario N4S 0A8, Kanada
Tel: +1 (0)519 5398531
Fax: +1 (0)519 5373339

USA

Honeywell Process Solutions

Mercury Instruments LLC
3940 Virginia Avenue
Cincinnati, Ohio 45227, USA
Tel: +1 (0)513 272-1111
Fax: +1 (0)513 272-0211

TURKEY

Honeywell Process Solutions

RMG GAZ KONT. SIS. ITH. IHR. LTD. STI.
Birlik Sanayi Sitesi, 6.
Cd. 62. Sokak No: 7-8-9-10
TR - Sasmaz / Ankara, Türkei
Tel: +90 (0)312 27810-80
Fax: +90 (0)312 27828-23