

Flow control valve RMG 530-E-WG DN 500/500



PRODUCT INFORMATION

**Serving the Gas Industry
Worldwide**



by Honeywell

Flow control valve RMG 530-E-WG DN 500/500

Application, properties, technical specifications

Applications

- For feeding gas into and/or withdrawing gas from gas storage facilities and important gas mains
- For all tasks in connection with optimising gas supply
- For all tasks of flow-rate or gas-pressure control with small change dynamics
- Bi-directional operation
- Suitable for gases according to DVGW Worksheet G 260 and neutral, non-aggressive gases – Other gases: on enquiry.

2

Characteristics

- Main valve with electric variable-speed drive
- In-line flow guarantees very high flow rates
- Valve sleeve with full compensation of static inlet and outlet pressures
- Comes with standard noise-reducing devices, additional/optional devices are available on request
- Valve performance curve may be adjusted to match prevailing operating conditions
- In case auxiliary energy fails → valve stays put in last position (function: fail position (FP))
- Electric variable-speed drive is suitable for three-step control with PI behaviour in combination with electric pilots
- Frequency-dependent valve control speeds are possible – setting by means of a frequency converter depending on operating conditions
- Explosion-proof design

Specifications					
Actuator unit					
Max. admissible pressure PS	depending on flange pressure stage up to 105 bar				
Max. operating pressure p_{max}; bi-directional operation possible	depending on flange pressure stage up to 105 bar				
Pipe size DN* Valve seat diameter, valve stroke and K_G value	Inlet	Outlet	Valve seat	Valve stroke	(Valve) flow rate coefficient K _G ** (m ³ /h)/bar
	500	500	480	215	198.000
Type of connection	Flange class 600 accor. to ANSI 16.5				
Temperature range class 2 (DIN) EN 334	Ambient and operating temperatures –20 °C to +60 °C (Other temperature ranges on enquiry)				
Valve sleeve	– with full compensation of static inlet and outlet pressures – with oxide-ceramic surface coating to protect guide and sealing areas				
Bubble-tight shut off of final control element (valve seal)	Bubble-tight shut off accor. to DIN EN 334 by means of elastic sealing ring				
Integrated primary noise attenuation	standard				

* other pipe sizes on enquiry

** for natural gas w/d = 0.64 (ρ_n ≈ 0.83 kg/m³) and t_u = 15 °C gas inlet temperature

Flow control valve RMG 530-E-WG DN 500/500

Application, properties, technical specifications

3

Specifications		
Electric variable-speed drive/electric control		
Power supply	400 V 3-phase AC, 50 Hz – other frequencies available on request	
Power consumption	0.56 kW	
Control	3-step control → ccw/OFF/cw	
Nominal speed n_{50}	definition accor. to valve travel time t_f	
Stroke limiting switch; WE_{min}/WE_{max}	standard for valve stroke 0 and 100 %	
Emergency torque limiting switch DME	standard for both directions	
Explosion protection of variable-speed drive	II 2 G EEx de IIC T4/de IIC T3*	
Electrical control	Power supply unit	with standard drive systems (make: Drehmo): optional use of a frequency converter is possible
	Control unit (automation)	control via programmable logic controller (PLC) or micro-controller
Actuator unit		
Mechanical transmission of power	via rotary drive	
Variable speed drive/final control element		
Valve travel time t_f	approx. 1 to 4 min. per stroke, depending on type	
Position indicator (valve stroke 0 – 100 %)	remote position indicator potentiometer 5 k Ω via ex-protection isolating amplifier – also 0/4 – 20 mA signal	
Materials	casing	cast steel (RMG standard)
	internal parts of main valve	steel, spheroidal iron, Ms, Al alloys
	sealing ring	rubber plastics (NBR), PTFE
Strength – leak proofness – functionality	following DIN EN 334	
Explosion protection, general	All mechanical components of this device are without potential ignition sources and/or hot faces. They are not subject to ATEX 95 (94/9/EC). All electronic accessories, on the other hand, meet ATEX requirements.	

* depends on variable speed drive

Registration	
CE registration according to PED	pending

Flow control valve RMG 530-E-WG DN 500/500

Design and operation

Applications

The flow control valve RMG 530-E-WG DN 500/500 has been designed for flow-rate and gas-pressure control duties with small change dynamics – in particular for volume/supply optimisation (feeding gas into and/or withdrawing gas from gas storage facilities and important mains). But first and foremost, this product is at home wherever maximum gas flow must be achieved even at smallest pressure differences.

This flow control valve may be operated as a bi-directional valve.

4

Functional description

The flow control valve RMG 530-E-WG DN 500/500 may be used as a final control element in electronic flow rate and/or pressure control loops. There is an electric variable-speed drive to adjust the travel of the valve sleeve (i.e. change the stroke). The variable speed drive is integrated with the final control element, thus transferring the torque of the motor directly to the shaft of the control valve. The rotary drive and spindle unit converts the rotary motion of the shaft into the axial stroke required for the valve sleeve. That way, the opening of the valve can be adjusted.

The flow control valve RMG 530-E-WG DN 500/500 has been designed with a minimum of parts to provide for easy maintenance. The final control element consists of one axial inline body. Valve sleeve with full static pressure compensation between inlet and outlet. The valve sleeve sits in the expansion sleeve. Thanks to a special coating, it requires only minimum forces during adjustments. To reduce noise, the design makes recourse to the well-proven method of splitting the jet in the expansion sleeve (perforated flow restrictor). The operating side of the variable speed drive may be arranged as needed.

Flow control valve RMG 530-E-WG DN 500/500

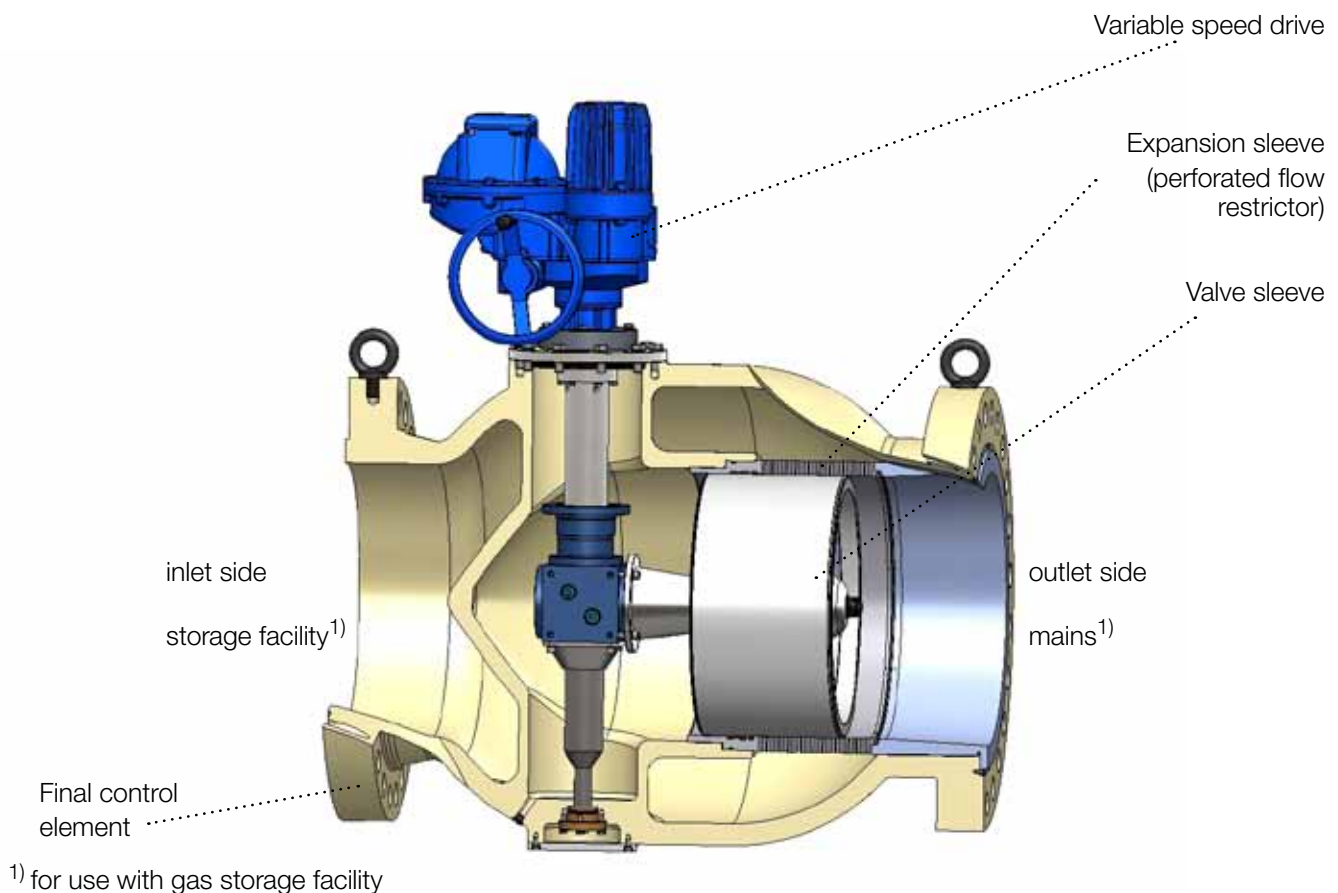

Flow control valve RMG 530-E-WG DN 500/500

Dimensions and weights

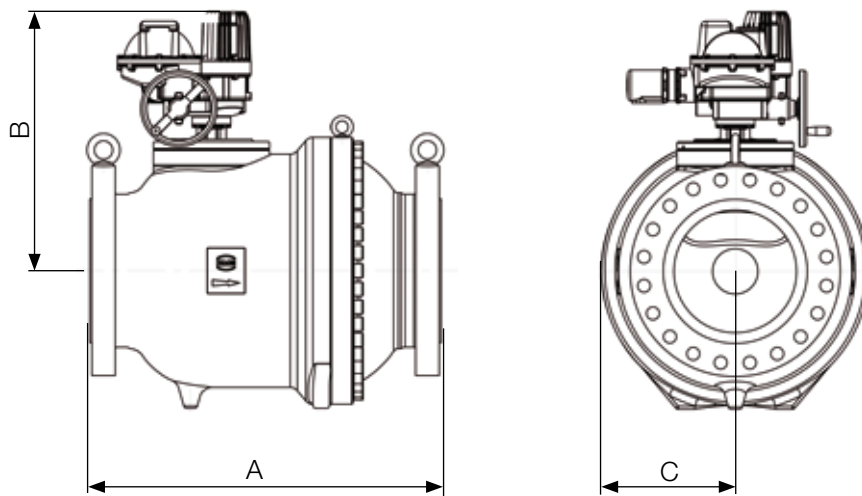

Dimensions and weight						
Nominal width		Valve seat diameter in mm	A in mm	B* Drehmo in mm	C* in mm	Weight (approx.) in kg
Inlet	Outlet					
500	500	480	1194	874	450	1700

* depends on drive

Flow control valve RMG 530-E-WG DN 500/500

Description

Example

RMG 530-E-WG DN 500/500 - 480 - 1 - FU - A - So

Type of equipment
 DN inlet
 DN outlet
 Valve seat
 Variable speed drive
 Electric control
 Automation
 Special design

Final control element		
Pipe size DN		Valve seat in mm
Inlet	Outlet	VS
500	500	480

Variable speed drive

Make: EMG (Drehmo)	1
--------------------	---

Electric power control

Frequency converter	FU
---------------------	----

Electric signal control

Automation (Please specify details)	A
-------------------------------------	---

Special design (Please specify details)	So
---	----

More information

You want to know more about the solutions RMG can offer to the gas industry? Talk to your local contact. Or visit our website www.rmg.com

GERMANY

Honeywell Process Solutions

RMG Regel + Messtechnik GmbH
Osterholzstrasse 45
34123 Kassel, Germany
Phone: +49 (0)561 5007-0
Fax: +49 (0)561 5007-107

Honeywell Process Solutions

RMG Messtechnik GmbH
Otto-Hahn-Strasse 5
35510 Butzbach, Germany
Phone: +49 (0)6033 897-0
Fax: +49 (0)6033 897-130

Honeywell Process Solutions

RMG Gaselan Regel + Messtechnik GmbH
Julius-Pintsch-Ring 3
15517 Fürstenwalde, Germany
Phone: +49 (0)3361 356-60
Fax: +49 (0)3361 356-836

Honeywell Process Solutions

WÄGA Wärme-Gastechnik GmbH
Osterholzstrasse 45
34123 Kassel, Germany
Phone: +49 (0)561 5007-0
Fax: +49 (0)561 5007-207

POLAND

Honeywell Process Solutions

Gazomet Sp. z o.o.
ul. Sarnowska 2
63-900 Rawicz, Poland
Phone: +48 (0)65 5462401
Fax: +48 (0)65 5462408

ENGLAND

Honeywell Process Solutions

Bryan Donkin RMG Gas Controls Ltd.
Enterprise Drive, Holmewood
Chesterfield S42 5UZ, England
Phone: +44 (0)1246 501-501
Fax: +44 (0)1246 501-500

CANADA

Honeywell Process Solutions

Bryan Donkin RMG Canada Ltd.
50 Clarke Street South, Woodstock
Ontario N4S 0A8, Canada
Phone: +1 (0)519 5398531
Fax: +1 (0)519 5373339

USA

Honeywell Process Solutions

Mercury Instruments LLC
3940 Virginia Avenue
Cincinnati, Ohio 45227, USA
Phone: +1 (0)513 272-1111
Fax: +1 (0)513 272-0211

TURKEY

Honeywell Process Solutions

RMG GAZ KONT. SIS. ITH. IHR. LTD. STI.
Birlik Sanayi Sitesi, 6.
Cd. 62. Sokak No: 7-8-9-10
TR - Sasmaz / Ankara, Turkey
Phone: +90 (0)312 27810-80
Fax: +90 (0)312 27828-23