

Gas Pressure Regulator RMG 402



PRODUCT INFORMATION

**Serving the Gas Industry
Worldwide**



Application

- for gas supply to municipal distribution systems, industrial and power plants
- for natural gas according to DVGW G 260, other gases on request

Characteristics

- large inlet pressure range
- diaphragm valve as control element
- pilot integrated in actuator head (for outlet pressure range up to 4 bar)
- optional: safety cut-off valve incorporated in main valve body (SSV)
- CE-sign according to pressure equipment directive PED
- small number of integral parts, easy maintenance, low noise
- approved as an equipment accessoire according to gas appliance directive

TECHNICAL DATA				
max. inlet pressure $p_{u\ max}$	25 bar with pilot RMG 620 50 bar with pilot RMG 630a/640			
specific pressure range W_{ds}	W_{ds} in bar	spring no.	spring colour	\varnothing in mm
pilot RMG 620 (integrated pilot, up to $p_{u\ max} \leq 25$ bar)	0.020 to 0.150	2	blue	3.6
	0.100 to 0.500	3	yellow	5.6
	0.200 to 1.000	4	brown	6.3
	0.500 to 2.000	5	red	7.0
	1.000 to 4.000	6	green	8.0
specific pressure range W_{ds}	W_{ds} in bar	spring no.	spring colour	\varnothing in mm
pilot RMG 630a (only in combination with RMG 720/K6 and RMG 721) (external pilot, two stage version)	0.30 to 1.00	1	black	4.5
	1.00 to 5.00	2	yellow	5.6
	2.00 to 10.0	3	brown	6.3
	5.00 to 20.0	4	red	7.0
	10.0 to 40.0	5	green	8.0
load limiting stage	5.00 to 15.0 automatically above p_d		green	5.0
specific pressure range W_{ds}	W_{ds} in bar	spring no.	spring colour	\varnothing in mm
pilot RMG 640 (only in combination with RMG 720/K6 and RMG 721) (external pilot, one stage version, for inlet pressure changes < 15 bar)	0.30 to 1.00	1	black	4.5
	1.00 to 5.00	2	yellow	5.6
	2.00 to 10.0	3	brown	6.3
	5.00 to 20.0	4	red	7.0
	10.0 to 40.0	5	green	8.0
min. pressure differential Δp_{min}	differential between inlet pressure and outlet pressure $\geq \Delta p$ 0.5 bar			
material				
main valve body	ductile iron / cast steel			
main valve internal parts	aluminium alloy / steel			
pilot	aluminium alloy / steel			
cut-off valve actuator	aluminium alloy / steel			
diaphragms	rubber like plastic material (NBR, ECO)			
sealings	rubber like plastic material (NBR)			

GAS PRESSURE REGULATOR RMG 402

Application, Characteristics, Technical Data

TECHNICAL DATA			
flow rate coefficient	(KG-value for natural gas, $\rho_n=0.83 \text{ kg/m}^3$)		
	inlet/outlet		KG-value
	DN 25 / DN 25	(ductile iron only)	350 m ³ /h
	DN 50 / DN 50		1300 m ³ /h
	DN 80 / DN 80		3500 m ³ /h
DN 100 / DN 100		5200 m ³ /h	
connections:			
ductile iron body	DIN-flanged to PN 16, PN 25 and ANSI 150		
cast steel body	DIN-flanged to PN 16, PN 25, PN 40 and ANSI 150, ANSI 300		
RMG 402 mit $DN_u=DN_d$ (without expansion)	inlet/outlet		KG-value
	DN 50 / DN 100		1500 m ³ /h
	DN 80 / DN 150		3800 m ³ /h
	DN 100 / DN 200		5500 m ³ /h
	connections:		
cast steel iron body	DIN-flanged to PN 16, PN 25, PN 40 and ANSI 150, ANSI 300		
accuracy class and closing pressure category	pd-range	accuracy class AC	closing pressure category SG
	up to 30 mbar	*10	30
	30 - 100 mbar	*5	20
	100 - 500 mbar	*5	10
	above 500 mbar	5	10
RMG 620	0.3 - 1 bar	20	30
	> 1 - 3 bar	5	10
	> 3 - 5 bar	5	10
	> 5 - 40 bar	2,5	10
	RMG 630a	0.3 - 1 bar	*20
> 1 - 3 bar		20	30
> 3 - 5 bar		10	20
> 5 - 40 bar		5	10
RMG 640		lock-up pressure zone class SZ 2,5	
	temperature class 2 -20°C to +60°C		
	function and strength acc. to EN 334 and EN 14382		
	DIN-DVGW-Reg.-No. NG-4301AS0043		
	CE-Reg.-No. CE-0085AT0082		
Ex-protection	The device does not have any potential ignition sources and thus ATEX 95 does not apply to it (applied electronic accessories comply with the ATEX requirements).		
CE - sign acc. to PED		acc. to the pressure equipment device PED (97/23/EG) and as equipment-part of gas-consumption-installations in accordance with the EC gas equipment device (90/396/EWG)	

*) for inlet pressure changes $\Delta p_u < 8 \text{ bar}$

Incorporation of safety cut-off devices

A safety cut-off valve can be incorporated in the regulator body as an optional feature. The cut-off unit can also be incorporated in regulators which have originally been delivered without. The gas pressure regulator RMG 402 can be equipped with the cut-off systems RMG720 and RMG 721 covering the following response ranges:

SAV-SYSTEM RMG 720 FOR SIZE DN 25 (P _{max} = 16 bar)									
actuator type	setpoint spring			overpressure cut-off p _{dso} *		underpressure cut-off p _{dsu} *		response pressure category	
	no.	colour	wire-Ø in mm	upper adjusting remge W _{dso} (bar)	minimum differential between response pressure and normal service pressure Δp _{w0} (bar)	lower adjusting range W _{dsu} (bar)	minimum differential between response pressure and normal service pressure Δp _{wu} (bar)		
K1a	1	yellow	2.5	0.05 ... 0.10	0.03			10/5	
	2	bright red	3.2	0.08 ... 0.25	0.05			10/5	
	3	light blue	3.6	0.20 ... 0.50	0.10			5/2.5	
	4	white	4.75	0.50 ... 1.50	0.20			5/2.5	
	5	light blue	1.1			0.010 ... 0.015	0.012	20	
	6	white	1.2			0.014 ... 0.040	0.030	10/5	
	7	black	1.4			0.035 ... 0.120	0.060	5	
K2a	2	bright red	3.2	0.40 ... 0.80	0.10			10/5	
	3	dark red	3.6	0.60 ... 1.60	0.20			10/5	
	4	white	4.75	1.50 ... 4.50	0.30			5/2.5	
	5	light blue	1.1			0.060 ... 0.150	0.050	10/5	
	6	black	1.4			0.120 ... 0.400	0.100	5	
SAV-SYSTEM RMG 720 FOR SIZE ≥ DN 50 (P _{max} = 25 bar)									
K4	2	bright red	3.2	0.04 ... 0.10	0.02			5/2.5	
	3	dark red	3.6	0.08 ... 0.25	0.03			2.5	
	4	black	4.5	0.20 ... 0.50	0.06			2.5/1	
	5	light blue	1.1			0.005 ... 0.020	0.01	20/5	
	6	black	1.4			0.015 ... 0.060	0.02	5	
K5	3	dark red	3.6	0.20 ... 0.80	0.10			2.5	
	4	black	4.5	0.60 ... 1.50	0.20			2.5/1	
	5	light blue	1.1			0.015 ... 0.050	0.03	20/5	
	6	black	1.4			0.040 ... 0.120	0.06	5	
K6	3	dark red	3.6	0.60 ... 2.00	0.20			2.5	
	4	black	4.5	1.50 ... 4.50	0.40			2.5/1	
	5	light blue	1.1			0.040 ... 0.120	0.06	20/5	
	6	black	1.4			0.120 ... 0.300	0.12	5	

*) Please note: if actuators are used simultaneously for upper and lower response settings, the pressure differential between the two setpoints p_{dso} and p_{dsu} should be at least 10% larger than the sum of the values Δp_{w0} and Δp_{wu}:

$$p_{dso} - p_{dsu} \geq 1,1 \times (\Delta p_{w0} + \Delta p_{wu})$$

**) The higher response precision category is valid for the first half, the lower response precision category is valid for the second half of the setting range.

GAS PRESSURE REGULATOR RMG 402

Application, Characteristics, Technical Data

SAV-SYSTEM RMG 721 FOR SIZES DN 50 AND LARGER (P _{max} = 50 bar)								
actuator type	setpoint spring			overpressure cut-off p _{dso} *		underpressure cut-off p _{dsu} *		response pressure category
	no.	colour	wire-Ø in mm	upper adjusting remge	minimum differential between response pressure and normal service pressure	lower adjusting range	minimum differential between response pressure and normal service pressure	
				W _{dso} (bar)	Δp _{w0} (bar)	W _{dsu} (bar)	Δp _{wu} (bar)	AG**
K10a	1	yellow	2.5	0.05 ... 0.10	0.03			10/5
	2	bright red	3.2	0.08 ... 0.25	0.05			10/5
	3	dark red	3.6	0.20 ... 0.50	0.10			5/2.5
	4	white	4.8	0.40 ... 1.50	0.25			5/2.5
	5	light blue	1.1			0.010 ... 0.015	0.012	20
	6	white	1.2			0.014 ... 0.040	0.030	20/5
	7	black	1.4			0.035 ... 0.120	0.060	5
K12	1	light green	5.0	0.50 ... 1.50	0.25			5/2.5
	2	yellow	6.3	1.00 ... 3.00	0.50			2.5/1
	3	bright red	8.0	2.00 ... 8.00	1.00			2.5/1
	4	white	2.0			0.100 ... 0.200	0.200	20
	5	light blue	2.8			0.150 ... 0.800	0.400	10/5
	6	black	3.6			0.500 ... 2.000	0.800	10/5
K13	2	yellow	6.3	4.00 ... 14.0	2.00			2.5/1
	3	bright red	8.0	7.00 ... 30.0	4.00			2.5/1
	4	white	2.0			0.500 ... 1.200	0.800	10
	5	light blue	2.8			0.700 ... 3.500	1.500	10/5
	6	black	3.6			1.500 ... 6.000	3.500	10/5
K16 ¹⁾	0	blue	3.2	0.800 ... 1.500	0.10			2.5
	1	black	4.5	1.000 ... 5.000	0.20			2.5/1
	2	grey	5.0	2.000 ... 10.00	0.40			1
	3	brown	6.3	5.000 ... 20.00	0.80			1
	4	red	7.0	10.00 ... 40.00	1.20			1
K17 ¹⁾	2	grey	5.0			4.00 ... 10.00	0.400	5
	3	brown	6.3			5.00 ... 20.00	0.800	5
	4	red	7.0			10.00 ... 40.00	1.200	5

*) Please note: if actuators are used simultaneously for upper and lower response settings, the pressure differential between the two setpoints p_{dso} and p_{dsu} should be at least 10% larger than the sum of the values Δp_{w0} and Δp_{wu}:

$$p_{dso} - p_{dsu} \geq 1,1 \times (\Delta p_{w0} + \Delta p_{wu})$$

***) The higher response precision category is valid for the first half, the lower response precision category is valid for the second half of the setting range.

1) Actuator systems K16 and K17 can be used together.

Example: RMG 402 with outlet expansion, with pilot RMG 620 and safety cut-off unit RMG 720 / K 4

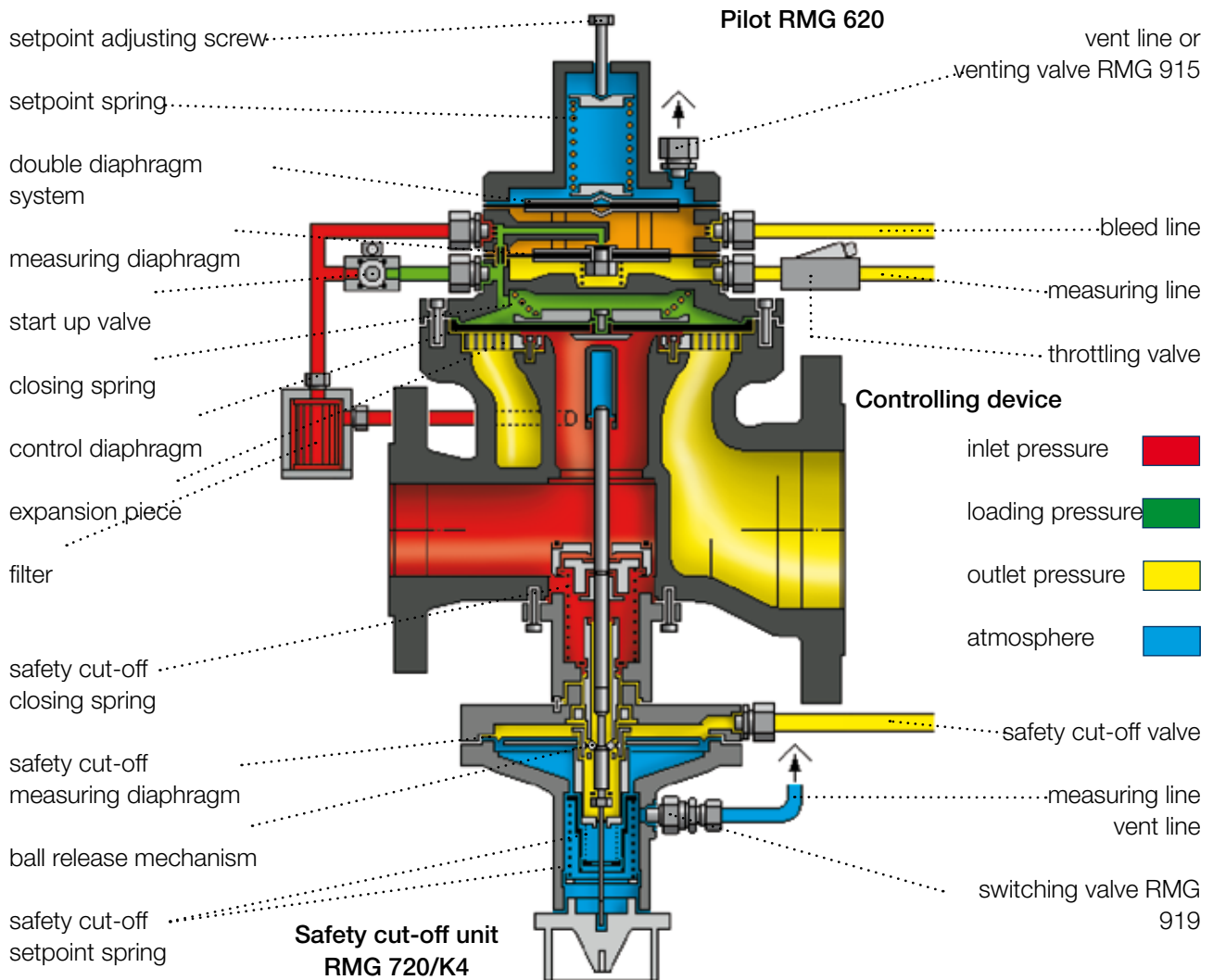

The gas pressure regulator RMG 402 was designed to keep the outlet pressure of a gaseous medium constant in the mains and independent of disturbing influences such as inlet pressure and flow rate changes. The RMG 402 consists of the main valve and the functional units „pilot“ and „safety cut-off valve“ (SAV). The regulator can be provided with an integrated or with a separate pilot unit. The separate pilot (RMG 630a or RMG 640) is connected to the main regulator through several impulse and operating lines. A filter mounted upstream protects the pilot from impurities. A safety cut-off unit can also be incorporated in regulators which had originally been delivered without safety cut-off. The small number of integral parts gives the advantage of easy maintenance of the regulating assembly: The upper part of the body can be removed easily thus facilitating a quick inspection of the control diaphragm - the only regulating part that is exposed to wear - without having to dismantle the main valve body from the line.

The safety cut-off unit can also be removed from the main valve body quite easily by just unscrewing the retaining screws. A special control diaphragm valve system takes over the function of the final control element. The control diaphragm rests upon an expansion piece with a circular sealing edge. A closing spring gives the force to ensure tight shut-off on zero flow.

A noise attenuation can be reached by fitting a metal foam ring below a special version of the expansion piece as an optional feature. Such exchange will, however, reduce the flow rate coefficient (KG value) by approx. 15 %.

GAS PRESSURE REGULATOR RMG 402

Design and Operation

Example: RMG 402 with outlet expansion, with pilot RMG 630a and safety cut-off system RMG 721/K10a

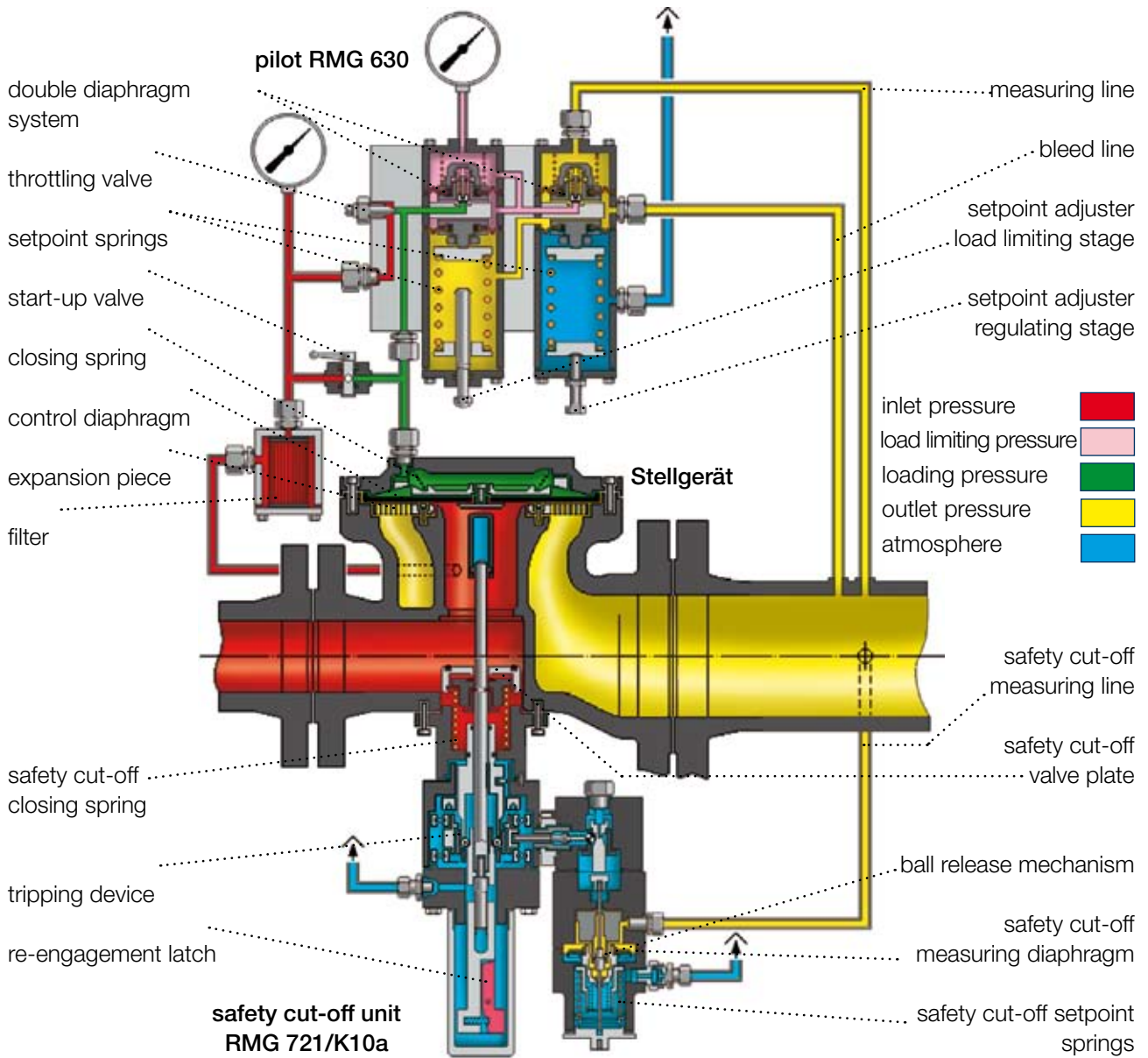

The outlet pressure to be controlled is fed into the pilot through the measuring impulse line. The double diaphragm system in the regulating stage of the pilot registers the actual outlet pressure as a force prevailing below the measuring diaphragm and compares it to the force given by the pre-adjusted setpoint spring. If this comparison shows deviations of the actual outlet pressure from the pre-set value, the pilot will react by changing the loading pressure in setting free as much of expansion piece surface as is necessary to adjust the outlet pressure to the pre-set value. Due to the design combination of the control diaphragm and the expansion piece the RMG 402 ensures regulating accuracy and stability even for very low flow rates. The regulator gives tight shut-off at zero flow.

The gas pressure regulator RMG 402 is provided with a starting valve to facilitate a quick pressure compensation at the control diaphragm upon pressurization. The RMG 402 can be equipped with the safety cut-off units RMG 720 or RMG 721 as an optional feature. Both safety cut-off systems consist of a valve unit with integrated pressure compensation, a tripping device and a measuring unit. The measuring units are provided with spring-loaded diaphragms for overpressure and underpressure release. The valve flap of the safety cut-off unit fitted into the inlet side of the regulator will close as soon as the outlet pressure will rise above or fall below the response setpoints. For details of safety cut-off design and operation, setting ranges and reengagement procedures please consult our relevant leaflets for the devices RMG 720 and RMG 721, together with the RMG -leaflet „General Operating Instructions for Gas Pressure Regulators and Safety Devices“.

Various examples of combining main body, pilot and safety cut-off valve are shown

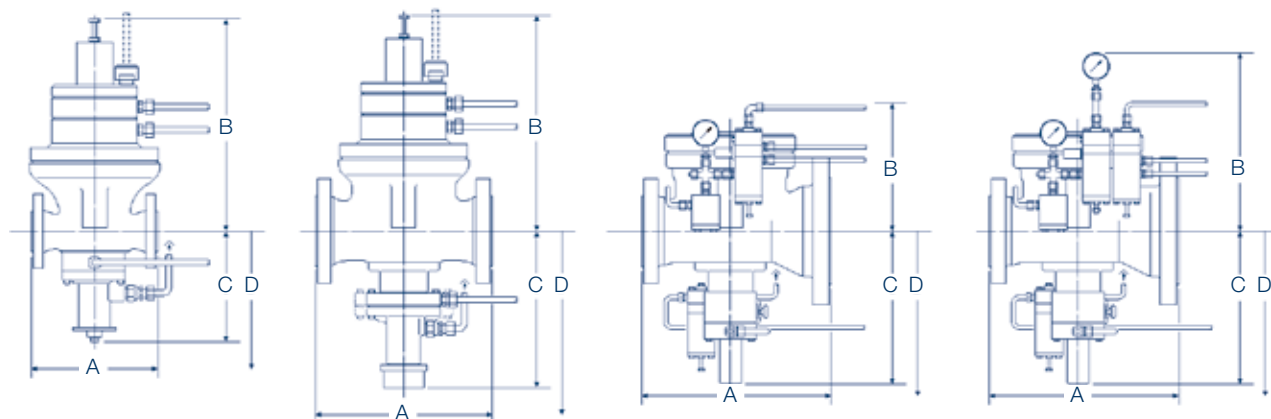

inlet size DN 25, with pilot RMG 620 and SSV-System RMG 720 (actuators K1a, K2a)

inlet size DN 50 and larger, with pilot RMG 620 and SSV-System RMG 720 (actuators K4, K5, K6)

inlet size DN 50 and larger, with pilot RMG 640 and SSV-System RMG 721 (actuators K10a, K12, K13, K16, K17)

inlet size DN 50 and larger, with pilot RMG 630 and SSV-System RMG 721 (actuators K10, K12, K13, K16, K17)

DIMENSIONS

size	body material	dimensions in mm							
		A pressure stage		B pilot		C safety shut-off valve		D dismantling dimensions	
		PN 16, PN 25, PN 40, ANSI 150	ANSI 300 $p_{max}=40$ bar	RMG 620	RMG 630/640	RMG 720	RMG 721	RMG 720	RMG 721
DN 25*	GJS**	184		360	370	180		260	
DN 50	GJS**	254		350	330	300	360	430	490
DN 80	GJS**	298		450	560	330	390	490	530
DN 100	GJS**	352		450	580	330	390	490	530
DN 50	GS	254	267	420	400	300	360	430	490
DN 80	GS	298	318	500	620	330	390	490	530
DN 100	GS	352	368	520	630	330	390	490	530
DN 50/100	GS	310		370	350	300	360	430	490
DN 80/150	GS	400		500	620	330	390	490	530
DN 100/200	GS	430		500	630	330	390	490	530

*) DN 25 with safety shut-off valve RMG 720 (actuators K1a and K2a) only up to max. inlet pressure of $p_{max} = 16$ bar

***) ductile iron body not available in pressure rating PN 40

CONNECTING LINES

a) RMG 402 with pilot RMG 620		c) safety cut-off valves RMG 720 and RMG 721	
measuring line	E 12	measuring line	E 12
bleed line	E 12	vent line	E 12
vent line	E 12*		
b) RMG 402 with pilot RMG 630a/RMG 640			
measuring line	E 12		
bleed line	E 12		
vent line	E 12*		

*) or venting valve RMG 915

WEIGHT

size	DN 25	DN 50	DN 80	DN 100	DN 50 / 100	DN 80 / 100	DN 100 / 200
appr. weight in kg	30	45	90	105	63	124	144

GAS PRESSURE REGULATOR RMG 402

Type Description (Example)

RMG 402 - 50/100 - K4 / F - 620 - So

type

size

safety cut-off unit

electric remote indication of safety cut-off valve

pilot type

special version

SIZES / DN	
size	size DN
without outlet expansion	25/25
	50/50
	80/80
	100/100
with outlet expansion	50/100
	80/150
	100/200

SAFETY CUT-OFF VALVE (SSV)			
safety cut-off valve (SSV) for DN 25			
adjustment range in bar			
W _{do}	W _{du}	p _{max}	actuator device
0,050 ... 1,500	0,010 ... 0,120	16 bar	K1a
0,400 ... 4,500	0,060 ... 0,400	16 bar	K2a
safety cut-off valve (SSV) for DN			
- without outlet expansion DN 50, DN 80, DN 100			
- with outlet expansion DN50/100, DN80/150, DN 100/200			
adjustment range in bar			
W _{do}	W _{du}	p _{max}	actuator device
0.040 ... 0.500	0.005 ... 0.060	25 bar	K4
0.200 ... 1.500	0.015 ... 0.120	25 bar	K5
0.600 ... 4.500	0.040 ... 0.300	25 bar	K6
0.050 ... 1.500	0.010 ... 0.120	40 bar	K10a
0.50 ... 8.00	0.10 ... 2.00	40 bar	K12
4.000 ... 30.00	0.50 ... 6.00	40 bar	K13
0.800 ... 40.00		40 bar	K16*
	4.00 ... 40.0	40 bar	K17*

TRIPPING AND ELECTRIC REMOTE INDICATION OF SAFETY CUT-OFF UNIT		
optional: safety cut-off remote release at	Stromgebung	E1
	current failure (only RMG 721)	E2
optional: safety cut-off manual release	for RMG 720: push button valve RMG 912	HA
	for RMG 721: integrated in system	
optional: electric remote indication of valve position „open/closed“		F

PILOT		
type	outlet pressure range in bar	pilot type
RMG 620	0.020 ... 4.000	620
RMG 630	0.300 ... 40.00	630
RMG 640	0.300 ... 40.00 ($\Delta p_u = < 15$ bar)	640

SPECIAL FEATURE	
special feature (to be specified in detail)	So

*) The actuator devices K 16 and K 17 can be applied in conjunction

For More Information

To learn more about RMG's advanced gas solutions, contact your RMG account manager or visit www.rmg.com

GERMANY

Honeywell Process Solutions

RMG Regel + Messtechnik GmbH
Osterholzstrasse 45
34123 Kassel, Germany
Tel: +49 (0)561 5007-0
Fax: +49 (0)561 5007-107

Honeywell Process Solutions

RMG Messtechnik GmbH
Otto-Hahn-Strasse 5
35510 Butzbach, Germany
Tel: +49 (0)6033 897-0
Fax: +49 (0)6033 897-130

Honeywell Process Solutions

RMG Gaselan Regel + Messtechnik GmbH
Julius-Pintsch-Ring 3
15517 Fürstenwalde, Germany
Tel: +49 (0)3361 356-60
Fax: +49 (0)3361 356-836

Honeywell Process Solutions

WÄGA Wärme-Gastechnik GmbH
Osterholzstrasse 45
34123 Kassel, Germany
Tel: +49 (0)561 5007-0
Fax: +49 (0)561 5007-207

POLAND

Honeywell Process Solutions

Gazomet Sp. z o.o.
ul. Sarnowska 2
63-900 Rawicz, Poland
Tel: +48 (0)65 5462401
Fax: +48 (0)65 5462408

ENGLAND

Honeywell Process Solutions

Bryan Donkin RMG Gas Controls Ltd.
Enterprise Drive, Holmewood
Chesterfield S42 5UZ, England
Tel: +44 (0)1246 501-501
Fax: +44 (0)1246 501-500

CANADA

Honeywell Process Solutions

Bryan Donkin RMG Canada Ltd.
50 Clarke Street South, Woodstock
Ontario N4S 0A8, Canada
Tel: +1 (0)519 5398531
Fax: +1 (0)519 5373339

USA

Honeywell Process Solutions

Mercury Instruments LLC
3940 Virginia Avenue
Cincinnati, Ohio 45227, USA
Tel: +1 (0)513 272-1111
Fax: +1 (0)513 272-0211

TURKEY

Honeywell Process Solutions

RMG GAZ KONT. SIS. ITH. IHR. LTD. STI.
Birlik Sanayi Sitesi, 6.
Cd. 62. Sokak No: 7-8-9-10
TR - Sasmaz / Ankara, Turkey
Tel: +90 (0)312 27810-80
Fax: +90 (0)312 27828-23

