

Gas Pressure Regulator RMG 370



PRODUCT INFORMATION

**Serving the Gas Industry
Worldwide**



GAS PRESSURE REGULATOR RMG 370

Application, characteristics, technical data

Application

- Direct-acting gas pressure regulator for commercial and industrial applications and local distribution stations.
- Suitable for non-aggressive gases: Other gases upon request.

Characteristics

- Gas pressure regulator with or without incorporated safety shut-off valve (SSV) – optionally with safety relief valve or safety diaphragm
- Valve diameter = nominal Size (DN) Exception: DN 150 - valve seat = 140 mm
- SSV with in-line flow - with pressure equalising device

TECHNICAL DATA												
max. allowable pressure	up to 20 bar											
Spring ranges	Diaphragm assembly RE 0			Diaphragm assembly RE 1			Diaphragm assembly RE 2			Diaphragm assembly RE 3		
	Setpoint spring			Setpoint spring			Setpoint spring			Setpoint spring		
Wds	No.	Colour code	Wire diameter in mm	No.	Colour code	Wire diameter in mm	No.	Colour code	Wire diameter in mm	No.	Colour code	Wire diameter in mm
< 20 mbar upon request				1	signal blue	3.6	1	signal blue	5	1	signal blue	7
20 mbar to 30 mbar				2	grey	4	2	grey	6.3	2	grey	7.5
25 mbar to 50 mbar				3	gentian blue	4.5	3	gentian blue	7	3	gentian	9
45 mbar to 75 mbar				4	yellow	4.5	4	yellow	7	4	blue	9.5
70 mbar to 100 mbar				5	bright red	5.3	5	bright red	8	5	yellow	11
90 mbar to 160 mbar				6	brown	5.3	6	brown	8	6	bright red	12
150 mbar to 200 mbar*				7	hazel	6.3	7	hazel	9		brown	
190 mbar to 260 mbar				8	light red	6.3	8	light red	9			
250 mbar to 300 mbar				9	rape yellow	7	9	rape yellow	10			
290 mbar to 360 mbar				10	dark red	7	10	dark red	10			
350 mbar to 400 mbar				11	light blue	7.5	11	light blue	11			
390 mbar to 500 mbar				12	rape yellow	8.5	12	rape yellow	11			
490 mbar to 560 mbar				13	creme white	9	13	creme white	12			
550 mbar to 660 mbar				14	gentian blue	9.5	14	gentian blue	12			
650 mbar to 760 mbar				15	emerald	9.5	15	emerald	13			
750 mbar to 800 mbar				16	green	9.5	16	green	13			
790 mbar to 900 mbar	1	creme white	8.5	17	bright red	10	17	bright red	14			
890 mbar to 1 bar	2	emerald	10		black			black				
1 bar to 2.5 bar		green										
Accuracy class AC and lock-up pressure class SG	AC ≥ 5 SG ≥ 10			AC ≥ 5 SG ≥ 10			AC ≥ 2.5 SG ≥ 10			AC ≥ 5 SG ≥ 10		
Outlet pressure range pd in bar												
Sizes	DN 25, DN 50, DN 80, DN 100, DN 150											
Connections	DIN flanges PN 16, class 150 acc. to ANSI 16.5											
Materials	main valve body					ductile iron, cast steel						
	Actuator housing					cast aluminium alloy						
Temperature range class 2	diaphragms, sealing rings					NBR / ECO						
	Internal parts					Al alloy, steel, brass						
Function and	accor. to DIN EN 334 and DIN EN 14382											
CE registration according to PED												

*) RE 3: 150 mbar to 260 mbar

GAS PRESSURE REGULATOR RMG 370

Application, characteristics, technical data

VALVE SPECIFICATIONS							
Sizes	Valve seat Ø (mm)	Flow rate coefficient KG* value in m ³ /(h · bar)		max. inlet pressure p _{max} in bar with diaphragm assembly			
		without noise red-	with noise reduction	RE 0	RE 1	RE 2	RE 3
DN 25	25	370	360	20	20		
DN 50	50	1500	1300	20	20	20	
DN 80	80	3000	2700	20		20	
DN 100	100	4500	3600			20 (10**)	20 (10**)
DN 150	140	13200	11900				20 (10**)

*) Flow rate coefficient for natural gas, (ρ_n= 0.83 kg/m³, t = 15°C)

***) Max. inlet pressure p_{u max} for DN 100 and DN 150 is limited to 10 bar not for reasons of strength but to keep accuracy.

SSV SPRING RANGES FOR ACTUATORS RMG 673, K1a AND K2a									
Actuator	Setpoint spring			Overpressure release p _{dso}		Underpressure release p _{dsu}		Accuracy Group ** AG	
	No.	Colour code	Wire Ø in mm	Upper setting range W _{dso} (bar)	Min. re-engage differential between response pressure and normal operating pressure* Δp _{wo} (bar)	Lower setting range W _{dsu} (bar)	Min. re-engage differential between response pressure and normal operating pressure* Δp _{wu} (bar)		
K1a	01	gentian blue	2.25	0.025 to 0.05	0.03			10 / 5	
	1	yellow	2.5	0.05 to 0.1	0.03			10 / 5	
	2	light red	3.2	0.08 to 0.25	0.05			10 / 5	
	3	dark red	3.6	0.2 to 0.5	0.1			5 / 2.5	
	4	white	4.75	0.5 to 1.5	0.25			5 / 2.5	
	5	yellow	1				0.005 to 0.015	0.012	20 / 10
	6	white	1.2				0.014 to 0.04	0.03	10 / 5
K2a	7	black	1.4			0.035 to 0.12	0.06	5	
	2	light red	3.2	0.4 to 0.8	0.1			10 / 5	
	3	dark red	3.6	0.6 to 1.6	0.2			10 / 5	
	4	white	4.75	1.5 to 4.5	0.3			5 / 2.5	
	04	gentian blue	5	4 to 5.2	0.3			5 / 2.5	
	5	light blue	1.1				0.06 to 0.15	0.05	10 / 5
	6	black	1.4			0.12 to 0.4	0.10	5	

*) PLEASE NOTE: If the actuator is configured to handle both overpressure and underpressure release, the difference between the set values of p_{dso} and p_{dsu} must exceed the sum of the values set for Δp_{wo} and Δp_{wu} by at least 10 %.

***) The higher AG group applies to the first half, the lower AG group to the second half of the setting range.

SAFETY RELIEF VALVE (SRV)				
No.	Setpoint spring		Diaphragm assembly	Response pressure * (mbar)
		Wire Ø in mm		
1		3.5	RE 1	15 - 90
1		3.5	RE 2	15
2		3.6		30
3		4.5		60
2		3.6	RE 3	15
3		4.5		30

*) relief range above regulator setpoint (p_{ds})

GAS PRESSURE REGULATOR RMG 370

Design and operation

Options

- Diaphragm assemblies 1, 2 and 3 optionally with safety relief valve (9) (pd up to 0.5 bar)
- SSV with manual release
- SSV with electromagnetic remote release
- Position indicator "SSV closed" (inductive proximity switch)
- Diaphragm assemblies 1 and 2 with safety diaphragm
- Vent valve RMG 915 for SSV and/or diaphragm assembly
- Without SSV
- Internal noise reducing features

Design and operation

The purpose of the direct-acting gas pressure regulator RMG 370 is to substantially stabilise the outlet pressure independently of any inlet-pressure and flow-rate changes in the regulating line. The device consists of a diaphragm assembly (1), final control element (2), SSV control element (3) with tripping device (4) and actuator (5) and the main valve body (6).

The control element of the diaphragm assembly is equipped with a balancing diaphragm (7). The diaphragm assemblies RE 1, RE 2 and RE 3 may be optionally equipped with a safety relief valve (9). The outlet pressure to be controlled is fed to the measuring unit via measuring line. The measuring unit compares the actual value with the setpoint defined by the force of the setpoint spring (10). If a deviation is detected, the valve stem (11) will adjust the control element (2) in order to match the actual value to the setpoint again. If the flow rate is zero, the device will seal bubble-tight.

The safety diaphragm (52) seals the spring housing in case of unexpected gas leakage.

A metal foam cylinder (12) may be inserted into the control element to reduce noise.

If the outlet pressure exceeds the predefined limits, the upstream safety shut-off valve (SSV) will stop the gas flow. In order to release the SSV due to high or low pressure, the pressure to be monitored is guided via measuring line under the diaphragm (20). If this pressure exceeds the value of any setpoint the tripping mechanism is shifted in such a way that the balls (21) release the valve stem (22). The spring-loaded switch stem will flip against the bush of the tripping device (4), thus unblocking the shaft (23) of the SSV control element (3) so that the SSV closes. Now the SSV may be opened only by hand. To accomplish that the outlet pressure at the measuring point must be reduced below the overpressure release / increased above the underpressure release by a value that must correspond at least to the re-engage differential (Δp).

Assembly, start-up and maintenance

For assembly and maintenance, please refer to relevant standard and rules as well as the Manual.

The "Operating and Maintenance Instructions / spare parts" contains detailed information on installation, start-up, maintenance and the most important spare and replacement parts.

This gas pressure regulator should preferably be installed in a horizontal position.

with safety diaphragm

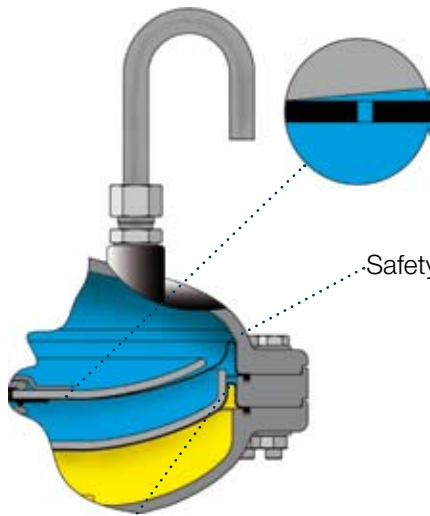

Safety diaphragm (52)

without safety diaphragm
with safety relief valve

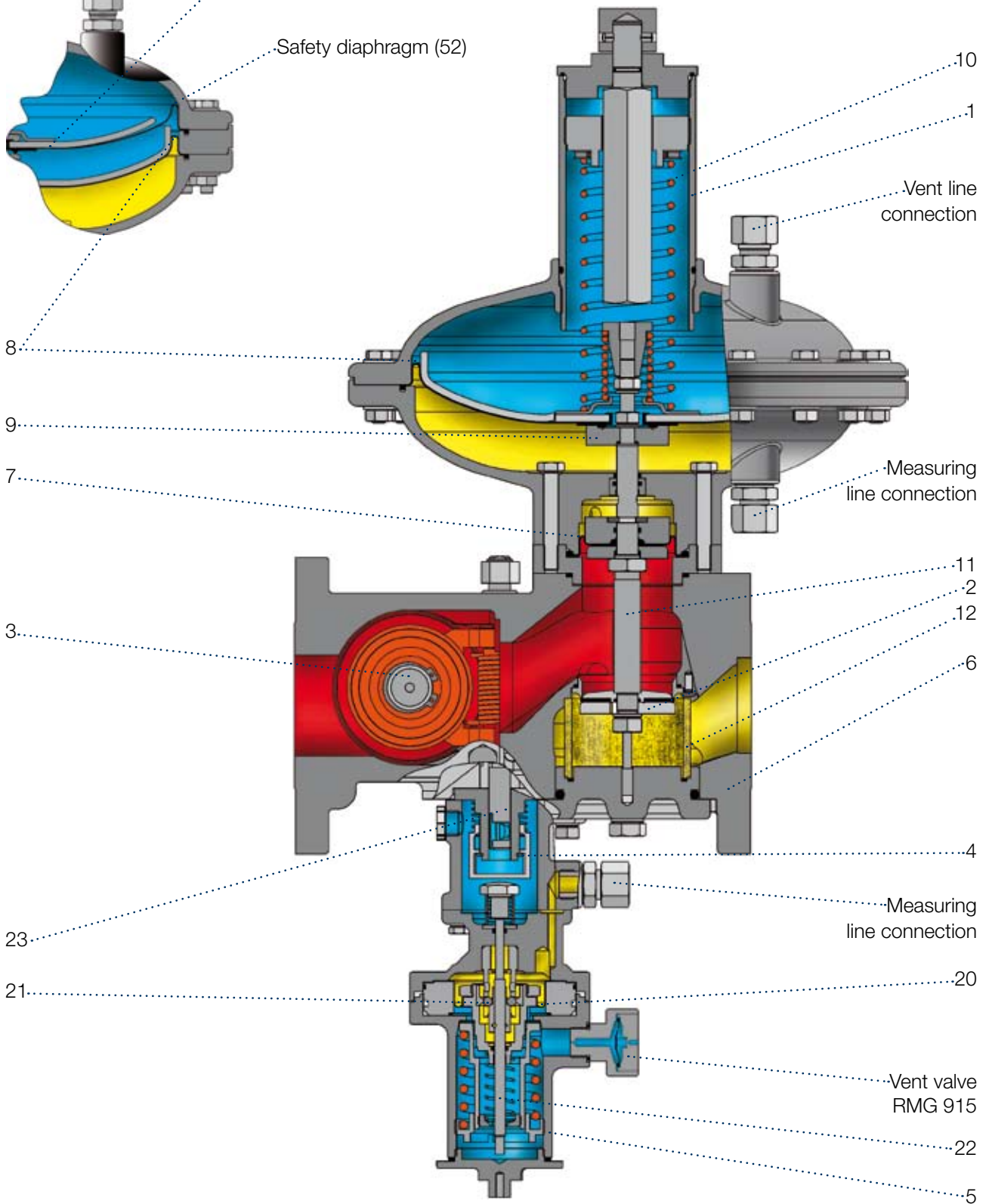

GAS PRESSURE REGULATOR RMG 370

Dimensions, weight and connection

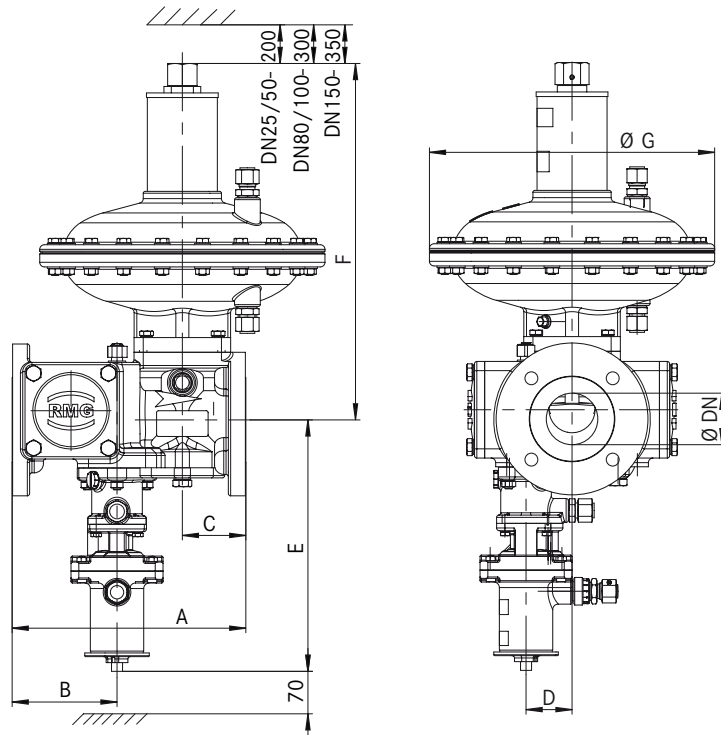

DIMENSIONS																	
DN	A	B	C	D	E	F				G				Weight			
						Diaphragm assembly				Diaphragm as-				Diaphragm assembly			
						RE0	RE1	RE2	RE3	RE0	RE1	RE2	RE3	RE0	RE1	RE2	RE3
in mm												in kg					
25	184	80	52	40	286	338	358	---	---	---	---	---	---	27	23	---	---
50	254*	114	75	50	273	364	387	506	---	195	310	---	---	34	34	45	---
80	298	140	83	65	345	562	---	550	---	---	---	400	---	65	---	59	---
100	352	160	100	72	350	---	---	550	600	225	---	---	---	---	---	75	92
150	451	227	120	106	340	---	---	---	680	---	---	---	560	---	---	---	152

*) Face to face dimensions 250 mm optional

CONNECTIONS OF MEASURING AND VENT LINES			
	Actuator		SSV controller
	Measuring line	Vent / discharge line	Measuring and vent lines
RE 0	Connection* for:	Connection* for:	Connection* for:
DN 25/50	Pipe 12 x 1.5 (thread M16 x 1.5)	Pipe 12 x 1.5	Pipe 12 x 1.5 (thread M16 x 1.5)
DN 80	Pipe 16 x 2 (thread M22 x 1.5)	(thread M16 x 1.5)	
RE 1	Pipe 12 x 1.5 (thread M16 x 1.5)		
DN 25/50			
RE 2	Pipe 12 x 1.5 (thread M16 x 1.5)	Pipe 12 x 1.5 (thread M16 x 1.5)	
DN 50 DN 80/100			
RE 3	Pipe 16 x 2 (thread M22 x 1.5)	Pipe 12 x 1.5 (thread M16 x 1.5)	
DN 100/150			

*) Pipe screw connection (without brazing) with compression joint accor. to DIN 2353

Connecting pieces: DN 25: screws M12 x L EN 24014 - 5.6 DN 50 to 100: screws M16 x L EN 24014 - 5.6
DN 150: screws M20 x L EN 24014 - 5.6 L may vary depending on type and version

Example

RMG 370 - 50 - K1a / E1 / HA / F - 50 / 1L / 3 - So

PIPE SIZE		Type					
DN 25		25	Pipe size DN				
DN 50		50					
DN 80		80					
DN 100		100					
DN 150		150					
ACTUATOR							
Setting range in bar							
	W _{ho}	W _{hu}					
K1a	0.025 to 1.5	0.005 to 0.12	K1a				
K2a	0.4 to 5.2	0.06 to 0.4	K2a				
ELECTROMAGNETIC REMOTE RELEASE							
Release upon	current supply / current loss		E1 / E2				
MANUAL RELEASE							
Manual release with push button valve RMG 912			HA				
REMOTE CONTROL							
Electrical remote indication of "CLOSED" position			F				
REGULATING ASSEMBLY							
DN	Size	Valve	SBV blocked	with SBV	with SM	Valve seat Ø	
25	RE 0	25	--	--	--	25	0
	RE 1		1	1L	1S		1...
50	RE 0	50	--	--	--	50	0
	RE 1		1	1L	1S		1...
	RE 2		2	2L	2S		2...
80	RE 0	80	--	--	--	80	0
	RE 2		2	2L	2S		2...
100	RE 2	100	2	2L	2S	100	2...
	RE 3		3	3L	--		3...
150	RE 3	140	3	3L	--	140	3...
SET RANGE							
W _d		Setpoint spring no.					
20 mbar to 30 mbar		1					
25 mbar to 50 mbar		2					
45 mbar to 75 mbar		3					
70 mbar to 100 mbar		4					
90 mbar to 160 mbar		5					
150 mbar to 200 mbar*		6					
190 mbar to 260 mbar		7					
250 mbar to 300 mbar		8					
290 mbar to 360 mbar		9					
350 mbar to 400 mbar		10					
390 mbar to 500 mbar		11					
490 mbar to 560 mbar		12					
550 mbar to 660 mbar		13					
650 mbar to 760 mbar		14					
750 mbar to 800 mbar		15					
790 mbar to 900 mbar		16					
890 mbar to 1 bar		17					
1 bar to 2.5 bar		1					
2 bar to 4 bar		2					

Type

Pipe size DN

SSV controller

Electromagnetic release

Manual release

Electrical remote indication of the "CLOSED" position

Valve seat diameter

Regulating assembly design

Regulating assembly setpoint spring no.

Special design (is to be specified)

*) RE 3: 150 mbar to 260 mbar

Technical modifications reserved

For More Information

To learn more about RMG's advanced gas solutions, contact your RMG account manager or visit www.rmg.com

GERMANY

Honeywell Process Solutions

RMG Regel + Messtechnik GmbH
Osterholzstrasse 45
34123 Kassel, Germany
Tel: +49 (0)561 5007-0
Fax: +49 (0)561 5007-107

Honeywell Process Solutions

RMG Messtechnik GmbH
Otto-Hahn-Strasse 5
35510 Butzbach, Germany
Tel: +49 (0)6033 897-0
Fax: +49 (0)6033 897-130

Honeywell Process Solutions

RMG Gaselan Regel + Messtechnik GmbH
Julius-Pintsch-Ring 3
15517 Fürstenwalde, Germany
Tel: +49 (0)3361 356-60
Fax: +49 (0)3361 356-836

Honeywell Process Solutions

WÄGA Wärme-Gastechnik GmbH
Osterholzstrasse 45
34123 Kassel, Germany
Tel: +49 (0)561 5007-0
Fax: +49 (0)561 5007-207

POLAND

Honeywell Process Solutions

Gazomet Sp. z o.o.
ul. Sarnowska 2
63-900 Rawicz, Poland
Tel: +48 (0)65 5462401
Fax: +48 (0)65 5462408

ENGLAND

Honeywell Process Solutions

Bryan Donkin RMG Gas Controls Ltd.
Enterprise Drive, Holmewood
Chesterfield S42 5UZ, England
Tel: +44 (0)1246 501-501
Fax: +44 (0)1246 501-500

CANADA

Honeywell Process Solutions

Bryan Donkin RMG Canada Ltd.
50 Clarke Street South, Woodstock
Ontario N4S 0A8, Canada
Tel: +1 (0)519 5398531
Fax: +1 (0)519 5373339

USA

Honeywell Process Solutions

Mercury Instruments LLC
3940 Virginia Avenue
Cincinnati, Ohio 45227, USA
Tel: +1 (0)513 272-1111
Fax: +1 (0)513 272-0211

TURKEY

Honeywell Process Solutions

RMG GAZ KONT. SIS. ITH. IHR. LTD. STI.
Birlik Sanayi Sitesi, 6.
Cd. 62. Sokak No: 7-8-9-10
TR - Sasmaz / Ankara, Turkey
Tel: +90 (0)312 27810-80
Fax: +90 (0)312 27828-23

