

# Gas Pressure Regulator RMG 322



PRODUCT INFORMATION

**Serving the Gas Industry  
Worldwide**



## Gas Pressure Regulator RMG 322

Application, characteristics, technical data

### Application

- for gas supply in the community grid, in workshops and industrial plants
- for natural gas and all non-corrosive gaseous media

### Characteristics

- large inlet pressure range
- can be provided with various valve sizes to improve rangeability
- valve inlet pressure compensation
- easy maintenance due to interchangeable cartridge assemblies (plug-in system)
- special versions for differential pressure regulation and as zero governor

TECHNICAL DATA			
Max. inlet pressure $p_{max}$	20 bar		
outlet pressure range	$W_h$ 0,010 bar to 15 bar		
sizes	DN 25 to DN 100		
connections	DIN-flanges PN 16 acc. to DIN 2501 and flanges acc. to ANSI 150 RF		
Durchflussmedium	Erdgas, Stadtgas, Luft, Stickstoff, andere Gase auf Anfrage		
accuracy class (AC) and lock up pressure class (SG)	AC $\geq 1$	SG $\geq 5$	
lock-up pressure zone	SZ 2,5		
material	valve body diaphragm case internal parts diaphragms, gaskets pilot	cast steel, ductile iron (DN 80 and DN 100) sheet steel aluminium, brass, steel synthetic rubber aluminium, brass, steel	
ambient temperature range class 2	- 20 °C to + 60 °C		
function and strength	acc. to EN 334		
PED / CE; DIN- DVGW	approved		

## Gas Pressure Regulator RMG 322

Application, characteristics, technical data

OUTLET PRESSURE RANGE						
pilot	load limiting unit			control unit		
		specific pressure range $W_a$ in [bar]	spring wire-dia. in [mm]		specific outlet pressure range $W_a$ in [bar]	spring wire-dia. in [mm]
RMG 610	measuring unit „M“	0,1 ... 1,5	3,3	measuring unit „N“	0,010 ... 0,040	2,5
					0,020 ... 0,060	3,0
					0,040 ... 0,120	3,5
					0,080 ... 0,200	4,0
					0,100 ... 0,500	5,0
		0,5 ... 5,0	4,7	measuring unit „M“	0,1 ... 1,5	3,3
					0,2 ... 2,5	4,0
					0,3 ... 3,5	4,5
RMG 650		1,0 ... 15,0	8,0		1 ... 5	4,5
				2 ... 10	5,0	
				5 ... 15	6,3	

VALVE DATA					
size	valve seat-dia. in mm	$K_G$ -value in $m^3/h$ for natural gas $r_n=0,83 \text{ kg}/m^3$	max inlet pressure $p_{emax}^*)$ in bar for actuator		length A in mm
			size 1	size 2	
DN 25	20	220	16	-	184
	33	480	16	-	
DN 50	25	400	-	16	254
	31	800	-	16	
	41	1300	-	16	
	50	1600	-	16	
DN 80	25	400	-	16	298
	31	900	-	16	
	41	1500	-	16	
	50	1800	-	16	
	60	2700	-	10 (16)	
	80	4000	-	6 (12)	
DN 100	25	400	-	16	352
	31	900	-	16	
	41	1500	-	16	
	50	1800	-	16	
	60	3100	-	10 (16)	
	80	4500	-	6 (12)	
	100	5800	-	4 (8)	

\*) The limitation of the inlet pressure range  $p_e$  for a diaphragm assembly is not given for reasons of material strength but in the interest of maintaining the regulating accuracy. The inlet pressure deviations though may not exceed the limit of the valve's nominal pressure rating.

## Gas Pressure Regulator RMG 322

---

### Design and function

This gas pressure regulator was designed to keep the outlet pressure of a gaseous medium constant in the mains and independent of disturbing influences like inlet pressure and/or flowrate changes.

The RMG 322 consists of a main valve with diaphragm assembly, and a pilot with preceding fine filter. For regular maintenance the integral parts of the main control element and the actuator can easily be taken out of the body and subjected to a visual inspection. In case of failure the modules can be replaced by spare units, and the repair works can be carried out in the workshop without having to shut down the system.

The main control element of the main valve is provided with an inlet pressure compensating diaphragm and can be equipped with orifices and actuators of various sizes.

The outlet pressure is controlled by a pilot with adjustable load limiter. The pressure differential between inlet pressure  $p_e$  and outlet pressure  $p_a$  serves as auxiliary energy to actuate the main valve control element via the diaphragm assembly. Optimal regulating stability can be reached by adjusting the load limiting pressure to adapt the regulator to particular site conditions.

The outlet pressure to be controlled is fed to the pilot through the measuring line. The measuring diaphragm takes up the actually prevailing outlet pressure and compares it to the pre-adjusted setpoint value given by the setpoint spring. Any deviation of the outlet pressure from the setpoint will cause a corresponding change of the loading pressure fed to the actuator, which controls the position of the valve plate. The resulting change in flow-rate will re-adjust the outlet pressure to the setpoint.

Via the return line the outlet pressure is also supplied to the underside of the actuator diaphragm, giving a direct influence upon the position of the valve plate and enabling fast regulation by the main valve.

The regulator gives tight shut-off on zero flow.

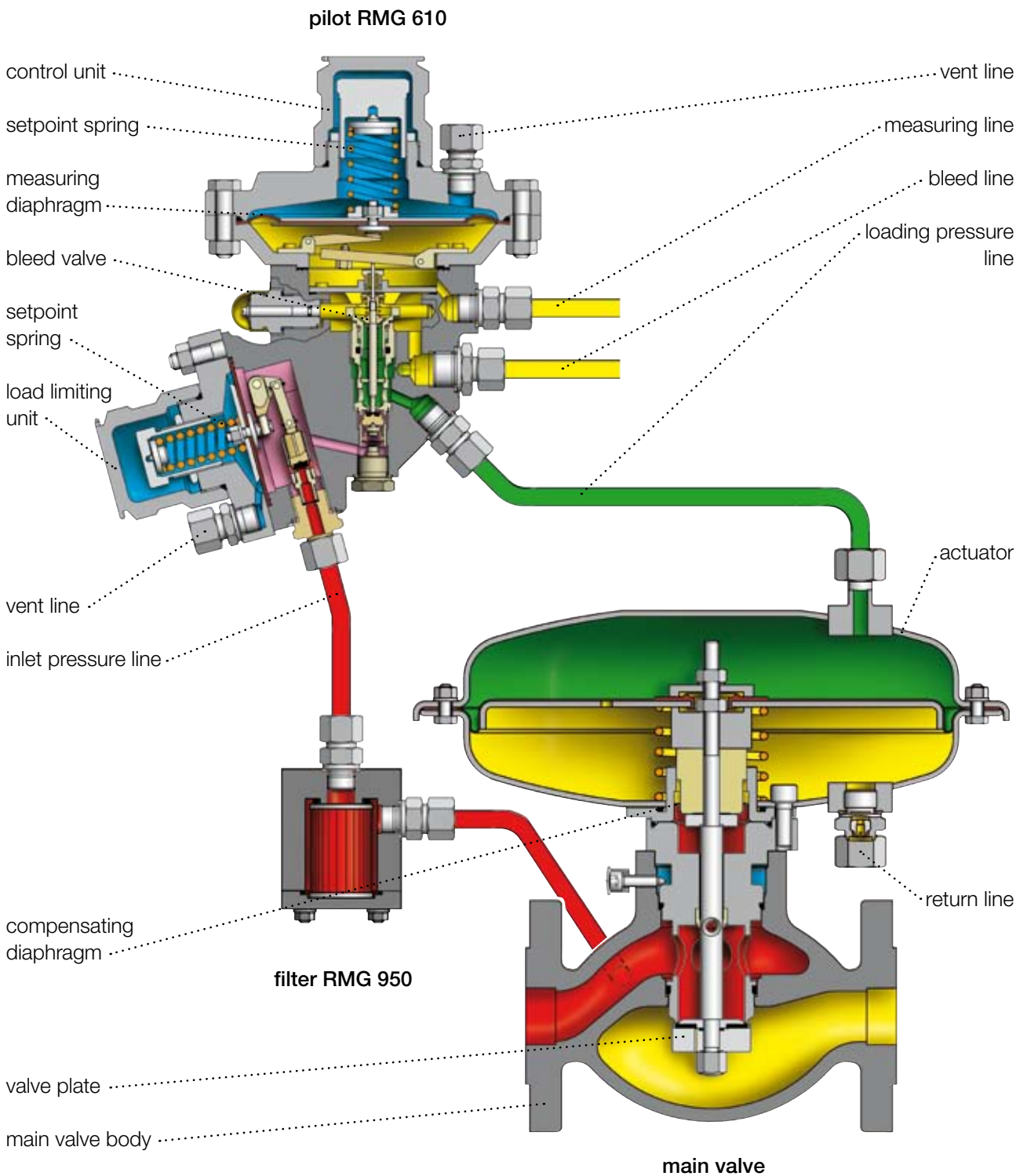

- inlet pressure
- outlet pressure
- load limiting pressure
- loading pressure
- atmosphere

# Gas Pressure Regulator RMG 322

Dimensions and connections

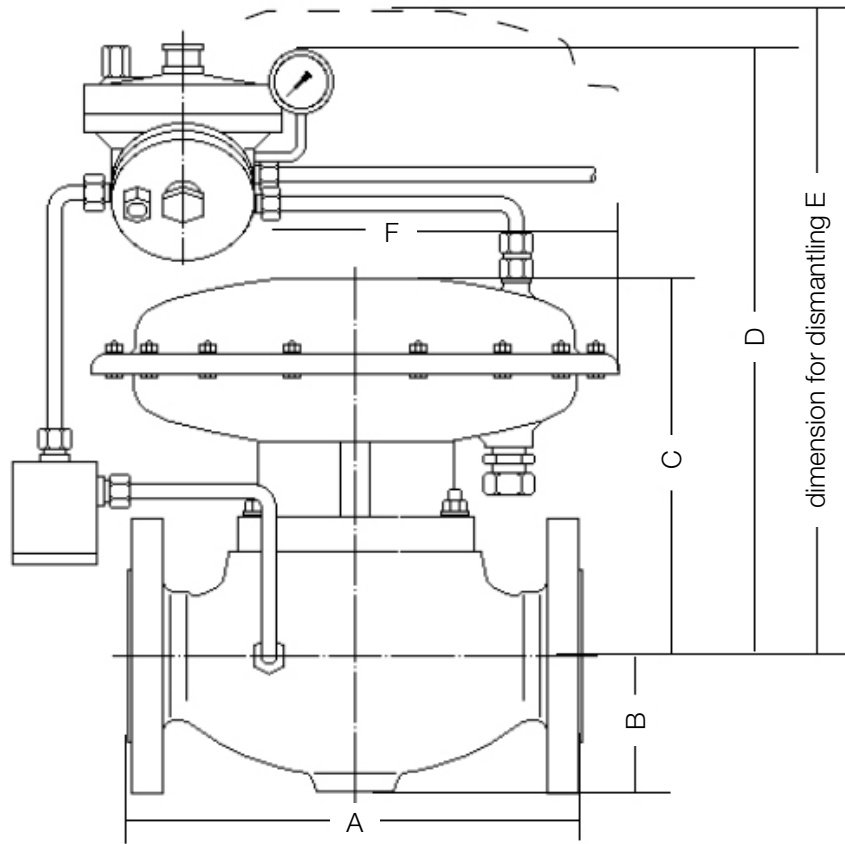

DIMENSIONS										
size DN	main valve body		actuator							
			size 1				size 1			
	A	B	C	D	E	F	C	D	E	F
25	184	60	265	460	460	300	-	-	-	-
50	254	90	-	-	-	-	275	525	550	400
80	298	130	-	-	-	-	340	610	635	400
100	352	130	-	-	-	-	360	610	635	400

CONNECTIONS						
size DN	dimensions of connection lines					
	measuring line	pilot			actuator	
		bleed line	vent line	return line		
				size 1	size 2	
25				pipe 12 x 1,5		
50	pipe 12 x 1,5	pipe 12 x 1,5	pipe 16 x 1,5		pipe 16 x 2,0	
80						
100						

# Gas Pressure Regulator RMG 322

Type description

example:

RMG 322 - 25 - 20 / 1 / MN - So

SIZE			
size			
DN 25		25	
DN 50		50	
DN 80		80	
DN 100		100	
VALVE SEAT DIAMETER AND ACTUATOR SIZE			
size	valve seat diameter in mm	actuator size	
DN 25	20	1	
	33	1	
DN 50	25	2	
	31	2	
	41	2	
	50	2	
DN 80	25	2	
	31	2	
	41	2	
	50	2	
	60	2	
DN 100	80	2	
	25	2	
	31	2	
	41	2	
	50	2	
	60	2	
	80	2	
	100	2	
	PILOT TYPE / OUTLET PRESSURE RANGE		
	pilot type	version	outlet pressure range $W_a$ in bar
RMG 610	MN	0,01 ... 0,50	
RMG 610	MM	0,10 ... 3,50	
RMG 650	-	1,00 ... 15,0	
SPECIAL VERSION			
special version (to be specified in detail)		So	

type

size DN

valve seat diameter

actuator size

pilot type and -version

special version

### **For More Information**

To learn more about RMG's Advanced Gas Solutions, contact your RMG account manager or visit [www.rmg.com](http://www.rmg.com)

### **GERMANY**

#### **Honeywell Process Solutions**

RMG Regel + Messtechnik GmbH  
Osterholzstrasse 45  
34123 Kassel, Germany  
Tel: +49 (0)561 5007-0  
Fax: +49 (0)561 5007-107

#### **Honeywell Process Solutions**

RMG Messtechnik GmbH  
Otto-Hahn-Strasse 5  
35510 Butzbach, Germany  
Tel: +49 (0)6033 897-0  
Fax: +49 (0)6033 897-130

#### **Honeywell Process Solutions**

RMG Gaselan Regel + Messtechnik GmbH  
Julius-Pintsch-Ring 3  
15517 Fürstenwalde, Germany  
Tel: +49 (0)3361 356-60  
Fax: +49 (0)3361 356-836

#### **Honeywell Process Solutions**

WÄGA Wärme-Gastechnik GmbH  
Osterholzstrasse 45  
34123 Kassel, Germany  
Tel: +49 (0)561 5007-0  
Fax: +49 (0)561 5007-207

### **POLAND**

#### **Honeywell Process Solutions**

Gazomet Sp. z o.o.  
ul. Sarnowska 2  
63-900 Rawicz, Poland  
Tel: +48 (0)65 5462401  
Fax: +48 (0)65 5462408

### **ENGLAND**

#### **Honeywell Process Solutions**

Bryan Donkin RMG Gas Controls Ltd.  
Enterprise Drive, Holmewood  
Chesterfield S42 5UZ, England  
Tel: +44 (0)1246 501-501  
Fax: +44 (0)1246 501-500

### **CANADA**

#### **Honeywell Process Solutions**

Bryan Donkin RMG Canada Ltd.  
50 Clarke Street South, Woodstock  
Ontario N4S 0A8, Canada  
Tel: +1 (0)519 5398531  
Fax: +1 (0)519 5373339

### **USA**

#### **Honeywell Process Solutions**

Mercury Instruments LLC  
3940 Virginia Avenue  
Cincinnati, Ohio 45227, USA  
Tel: +1 (0)513 272-1111  
Fax: +1 (0)513 272-0211

### **TURKEY**

#### **Honeywell Process Solutions**

RMG GAZ KONT. SIS. ITH. IHR. LTD. STI.  
Birlik Sanayi Sitesi, 6.  
Cd. 62. Sokak No: 7-8-9-10  
TR - Sasmaz / Ankara, Turkey  
Tel: +90 (0)312 27810-80  
Fax: +90 (0)312 27828-23

