

Gas Odorization System GOE 2000



PRODUCT INFORMATION

**Serving the Gas Industry
Worldwide**



Gas Odorization System GOE 2000

construction, method of operation, features

Construction

The individual components are fixed to a mounting plate which is installed above a collector. The odorant tank is also located on the collector at the same level as the reserve tank. Almost all valves are integrated into the enclosure of the reserve tank which reduces the number of pipe connections and possible leakages.

A permanently installed hand pump is used for filling the reserve tank during start-up and during the time when the odorant tank is changed. In this way, the liquid column is formed which enables the levels to be equalized according to the principle of communicating vessels. A gas trap prevents this liquid column from being interrupted.

An activated carbon filter prevents odorant from escaping to the outside when the system is vented. For monitoring purposes, the system can be equipped with a level switch (giving an alarm when the level falls below minimum) or a level detector (level measurement).

Method of operation

In order to immediately detect natural gas leaking, it is necessary to add an odorous substance (odorant) to the odourless natural gas. Special devices adding the odorant in the required concentration are used for this process, which is called odorization.

The GOE 2000 odorization system operates according to the injection method. An electromagnetically operated reciprocating diaphragm pump injects the odorant through an injection nozzle into the gas flow. The proportioning pump receives an electric pulse from the associated control unit and then performs a stroke which delivers a settable quantity of odorant. The number and sequence of pulses are determined by the control unit on the basis of volume-proportional pulses received from a volumetric meter. The odorant is drawn from a reserve tank into which it flows from a connected odorant tank according to the principle of communicating vessels.

Features

- **Odorizes according to the injection method**
Injection is performed by a reciprocating diaphragm pump which is controlled by volume-proportional pulses.
- **Odorant is drawn from the odorant tank according to the principle of communicating vessels**
No auxiliary pressure is required (neither overpressure nor underpressure). A permanently installed hand pump is used only when the system is started up or when the odorant tank is changed.
- **High proportioning accuracy**
In this way, a constant odorant concentration is achieved in the gas flow.
- **Wide operating range**
- **High level of reliability**
All parts coming into contact with the odorant are manufactured from stainless steel, glass or Viton.
- **Infinitely variable setting of the odorant concentration**
The setting of the odorant concentration can be performed at the pump and is also possible during operation.
- **Suitable for use with all common odorants**
e.g. for THT or mercaptans
- **Installed on a mounting plate with SWAGELOK fittings ready for connection**
- **Odorant tank can be changed without interrupting operation**
- **Venting the pump head poses no problems even if the gas line is under pressure**
- **Low on maintenance**
- **Equipped with a stored-program control unit**
- **Convertible to sulfur-free odorant.**

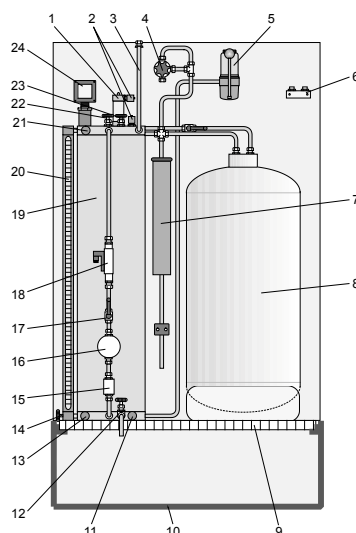

Construction of the GOE 2000

- 1 - Gas trap
- 2 - Measuring coupling
- 3 - Injection pipe
- 4 - Hand pump
- 5 - Flushing device
- 6 - Hose clamp
- 7 - Activated carbon filter
- 8 - Odorant tank
- 9 - Grid
- 10 - Collector
- 11 - Shut-off valve, flushing device
- 12 - Drain valve
- 13 - Shut-off valve, measuring burette
- 14 - Shut-off valve, reserve tank
- 15 - Filter
- 16 - Proportioning pump
- 17 - Ball valve
- 18 - Flow monitor
- 19 - Reserve tank
- 20 - Measuring burette
- 21 - Shut-off valve, measuring burette
- 22 - Start-up valve
- 23 - Filling valve
- 24 - Level detector or level switch

Options

- **Level switch** giving an alarm when the filling level falls below a preset minimum value.
- **Level detector** for continuous level measurement. The odorant concentration produced can be calculated automatically through the change in the filling level..
- **Flow monitor** installed in the injection pipe for monitoring the proportioning pump.
- **High-pressure flushing and venting device** for flushing the fittings installed in the suction and injection pipes and for venting the proportioning pump. Maximum gas back pressure: 80 bar.
- **Manual button** (EEx i or EEx d), including manual/automatic changeover, for manual pump control..

pliance with WHG (100 litres or 200 litres).

- **Weather-proof concrete cabinet** with separate, gas-tight electrical section for installing the GOE 2000 odorization system with odorant tank, collector and control unit.
- **Insulating coupling** for the injection pipe, dia. 6 mm, for the electrical isolation of the piping and the odorization system.
- **Odorant tank** as per DIN 30 650 (50 litres or 200 litres) for transportation and storage, approved by DVGW.
- **2 flexible PTFE hoses** with stainless-steel sheathing for connecting the odorant tank with the reserve tank.

Accessories

- **Injection nozzle** for injecting the odorant into the gas flow, including a non-return valve and a manual stop valve. There are different lengths available for nominal pipe diameters from DN 50 to DN 800.
- **Weldolet** (PN 100) for installing the injection nozzle, with G1/2", G3/4" or G1" internal thread.
- **Collector** made of stainless steel with grid and supporting feet, manufactured and tested in com-

Special design

The GOE 2000 odorization system can be equipped with a second proportioning pump that is used either as a standby pump which will start to operate automatically when the process pump fails or as a second pump which operates parallel to the first pump to increase the output.

Specifications		
Dimensions (H × W × D)		additional Gewicht:
GOE 2000 without collector	1225 × 720 × 770 mm	
100 l collector	300 × 770 × 770 mm	30 kg
200 l collector	400 × 1000 × 770 mm	40 kg
Weight¹⁾ (depending on pump type)	MH-6-47/ MH-6-65	MHO-15-300/ MHO-15-500
- GOE 2000 with 17l - reserve tank	62 kg	68 kg
- GOE 2000 with 35l - reserve tank	80 kg	86 kg
connection of injection pipe	Ø 6 mm SWAGELOK fitting	
power supply	230 V/AC (cia control unit)	
power requirement	approx. 56 VA	
ambient temperature range	+5 bis +50 °C	
reserve tank	17l when using a 50l odorant tank 35l when using a 200l odorant tank	
explosion protection (pump)	EEx e G 4, approved for Zone 1	
immersion length of injection nozzle	DN 50 - DN 100: 93 mm	DN 150: 143 mm
	DN 200: 178 mm	DN 250 - DN 300: 190 mm
	DN 400 - DN 500: 320 mm	DN 600 - DN 800: 480 mm

¹⁾ Without collector and odorant tank

For More Information

To learn more about RMG's advanced gas solutions, contact your RMG account manager or visit www.rmg.com

GERMANY

Honeywell Process Solutions

RMG Regel + Messtechnik GmbH
Osterholzstrasse 45
34123 Kassel, Germany
Tel: +49 (0)561 5007-0
Fax: +49 (0)561 5007-107

Honeywell Process Solutions

RMG Messtechnik GmbH
Otto-Hahn-Strasse 5
35510 Butzbach, Germany
Tel: +49 (0)6033 897-0
Fax: +49 (0)6033 897-130

Honeywell Process Solutions

RMG Gaselan Regel + Messtechnik GmbH
Julius-Pintsch-Ring 3
15517 Fürstenwalde, Germany
Tel: +49 (0)3361 356-60
Fax: +49 (0)3361 356-836

Honeywell Process Solutions

WÄGA Wärme-Gastechnik GmbH
Osterholzstrasse 45
34123 Kassel, Germany
Tel: +49 (0)561 5007-0
Fax: +49 (0)561 5007-207

POLAND

Honeywell Process Solutions

Gazomet Sp. z o.o.
ul. Sarnowska 2
63-900 Rawicz, Poland
Tel: +48 (0)65 5462401
Fax: +48 (0)65 5462408

ENGLAND

Honeywell Process Solutions

Bryan Donkin RMG Gas Controls Ltd.
Enterprise Drive, Holmewood
Chesterfield S42 5UZ, England
Tel: +44 (0)1246 501-501
Fax: +44 (0)1246 501-500

CANADA

Honeywell Process Solutions

Bryan Donkin RMG Canada Ltd.
50 Clarke Street South, Woodstock
Ontario N4S 0A8, Canada
Tel: +1 (0)519 5398531
Fax: +1 (0)519 5373339

USA

Honeywell Process Solutions

Mercury Instruments LLC
3940 Virginia Avenue
Cincinnati, Ohio 45227, USA
Tel: +1 (0)513 272-1111
Fax: +1 (0)513 272-0211

TURKEY

Honeywell Process Solutions

RMG GAZ KONT. SIS. ITH. IHR. LTD. STI.
Birlik Sanayi Sitesi, 6.
Cd. 62. Sokak No: 7-8-9-10
TR - Sasmaz / Ankara, Turkey
Tel: +90 (0)312 27810-80
Fax: +90 (0)312 27828-23