

Flow Control Valve RMG 530

DN 50/100 to DN 150/300



Operation and Maintenance, Spare Parts

valid for flow control valve RMG 530
and for the integrated SSV system RMG 711

from series no.
from series no.

530.20

edition 01/2001

9802 21801
9706 19948

Serving the Gas Industry - WORLDWIDE



contents		page
1.	general	3
1.1	safety notes	3
2.	flow control valve	4
2.1	special operating notices	4
2.2	special maintenance notices	4
2.2.1	removal and renewal of seals	4
2.2.2	assembly	5
2.2.3	setup of end position switches in electrical multiturn actuator	5
2.2.4	setup of torque switches in electrical multiturn actuator	6
2.2.5	dismantling the thrust drive	6
2.2.6	installing the thrust drive	7
2.2.7	screw tightening torques	7
2.2.8	lubricants	7
2.3.	spare parts	
2.3.1	spare parts drawings	
2.3.1.1	design with multiturn actuator	8, 9
2.3.1.2	design with thrust drive	10, 11
2.3.2	spare parts lists	
2.3.2.1	main valve	12, 13
2.3.2.2	design with multiturn actuator	14
2.3.2.3	design with thrust drive	15
2.3.3	spare parts for maintenance	16
3.	integrated SSV system RMG 711	
3.1	special operating notices	17
3.2	special maintenance notices	17
3.2.1	tripping device	17
3.2.2	main valve	18
3.2.3	screw tightening torques	18
3.2.4	lubricants	18
3.3	spare parts	
3.3.1	spare parts drawings	19, 20, 21
3.3.2	spare parts lists	22, 23
3.3.3	spare parts drawings accessories	24
3.3.4	spare parts lists accessories	25
3.3.5	spare parts for maintenance	26

1. general

For the flow control valve RMG 530 and the safety shut-off valve (SSV) system RMG 711 the detailed product information publications 530.00 and 711.00 containing the technical data, dimensions, and a description of their design and operation apply.

Notes on the operation of the electrical actuator are contained in the respective operating manual of the manufacturer of the actuator.

For the SSV control elements and the push button valve their separate operating and maintenance manuals and spare parts should be consulted:

SSV control element	K 10a / K 11a	672.20
SSV control element	K 16 / K 17 / K 18	670.20
Push button valve	RMG 910a	910.20
Push button valve	RMG 913a	913.20

The RMG publication "**General operating instructions for gas pressure regulators and safety systems**" contains information about the installation, commissioning, and operation, and includes notes on troubleshooting.

For planning through to maintaining gas pressure systems the applicable national regulations must be observed.

Germany: DVGW - work sheets G 600, G 459/II, G 490/I, G 491 and G 495

The time intervals for monitoring and maintenance tasks depend largely on the operating conditions and the type of gas used. It is, therefore, not possible to provide set intervals. It is recommended to keep to the maintenance intervals stated in DVGW - work sheet G 495.



During maintenance components must be cleaned and carefully checked. This must also be done where irregularities in operational characteristics are found during operation or during functional checks. The checks must extend in particular to diaphragms and seals as well as all moving components. Damaged parts must be replaced by new ones.

The item numbers given in the special operating and maintenance notices correspond to those in the spare part drawing and spare part list.

It is recommended to keep the parts marked "**W**" in the spare part drawings and spare part lists in stock for maintenance purposes. These parts are grouped together on a separate sheet.

1.1 safety notes

Safety notices are marked using the following key words or symbols

Marking	Used for:
	Danger to persons and equipment and environmental damage
	Important additional information

2. flow control valve

2.1. special operating notes

Prior to commissioning the notices on the attached label (530.11) must be observed. The electrical switches for stroke, torque, and the position feedback were preset at factory. The main valve is approx. 50% open when delivered.



When commissioning new systems, it is possible that impurities (e.g. shavings, welding beads, scales, etc.) from the area between filter and flow regulator will be carried. These can damage the seals. It is, therefore, recommended to install a startup sieve in front of the flow control valve.

2.2 special maintenance notes

The maintenance works are normally limited to the sealing elements of the actuator spindle and the main valve (bubble-tight sealing).



Prior to removal all chambers must be depressurised.

2.2.1 removal and renewal of seals

- Using the electrical actuator move valve sleeve to the "CLOSED" position (end position switch "CLOSED" disconnects).
- Remove the multiturn actuator with cover (100) after unscrewing the screws (102). Removal of an installed thrust drive see item 2.2.5.

Note

Mark the position of the actuator spindle (105) by means of the feather key (104) (important for reassembly).

- Loosen cylinder screws (111a) in adjusting nut (111) and unscrew adjusting nut using mandres fitted to the side.
- Unscrew cylinder bolts (17).
- Separate cover (12) from body (7) by screwing in 2 cylinder screws (102) in threads on opposite side.
- Slide out bush (46) from cover after unscrewing cylinder bolts (44).
- Renew seal (13). Note correct installation direction: **Circular spring points towards delivery side!**
- Slide out actuator spindle (105) including valve sleeve (6) from release sleeve (11).

Note

Mark installation direction of release sleeve (11) in body.

- Remove release sleeve (11) from body (7) using eyelet bolts M6 screwed into the face side.
- Renew sealing ring (28) and o-ring (29) after dismantling the ring (30).

2.2.2 assembly

Clean all components and install the components mentioned in the lubrication table after greasing. The screws must be inserted pre-greased and must be tightened with the torque M_A stated in table 2.2.7

Note

Lubricate actuator spindle (105), inner thread of ring (117), feather key (115), and feather key groove thick with grease. Fill lubrication chambers (15) with grease.

- Insert new o-rings (20, 24, 32) and GT ring (22) with bearing ring (21) pre-greased into the cleaned retaining groove.
- Whilst dismantled, insert valve sleeve (6) into release sleeve (11) and screw the guiding screws (33) evenly and lightly against the valve sleeve. Secure the guiding screws with locking nuts (34).
- Insert the release sleeve (11) into the marked position in the housing.
- Slide valve sleeve (6) with actuator spindle (105) into the release sleeve (11)
- Fit lower axial bearing (113).

Note

Observe the correct installation position of wave washer (112) and outer washer (114).

- Fit cover (12), observe correct fit of the centering pins!
- Fit upper axial bearing (113) montieren. Observe the correct installation position of wave washer (112) and outer washer (114).
- Slightly tighten adjusting nut (111) using a mandrel inserted into the side. Tighten cylinder bolts (111a) evenly to a torque of 3 Nm.
- Using an open-jawed spanner (SW 15) turn the actuator spindle clockwise up to the mechanical stop.

Note

Then turn back 2 turns anti-clockwise. This is the "CLOSED" position of the actuator spindle / feather key before disassembly.

- Tighten screws (17) using the appropriate torque.
- Fit electrical actuator in end position "CLOSED" with cover (100) onto the pre-greased actuator spindle.
- With this procedure it is **not** necessary to correct the end position switches in the electrical actuator.

2.2.3 setup of the end position switches in the electrical multiturn actuator



For all works on the electrical actuator the particulars of the manufacturer's operating manual must be followed.

If contrary to the procedure described above the end position switches need to be newly setup after disassembly, this is done as follows:

- Dismantle the electrical actuator
- Turn the actuator spindle with an open-jawed spanner (SW 15) clockwise up to the mechanical stop.

Note

Afterwards turn back 2 turns. This is the "CLOSED" position of the actuator spindle. Note the position of the feather key!

- Align the feather key groove in the electrical actuator with the feather key.
- Set the end of travel switch in this position to "CLOSED".
- Move multiturn actuator – not yet fitted – electrically towards "OPEN" whilst counting the turns of the actuator spindle from the "CLOSED" to the "OPEN" position. The end of travel switch is to be set in accordance with the number of turns given in the table below onto "OPEN".

Turns of the actuator spindle from position "CLOSED" to position "OPEN".

pipe size DN	turns
50/100	30
80/150	50
100/200	50
150/300	85

- Move multiturn actuator electrically into the "CLOSED" position. Check that the feather key groove in the actuator shaft and the feather key on the actuator spindle are aligned.

Note

Any required correction must be made at the end position switch.

- Fit multiturn actuator to main valve body.

2.2.4 setup of the torque switch in the electrical multiturn actuator

The procedure for setting up the torque switch is described in the manufacturer's operating manual. The factory setting for right and left handed rotation is **M = 30 Nm**.

2.2.5 dismantling the thrust drive

- Move valve sleeve to approx. 50% open valve position using the electrical actuator.
- Remove position indicator (211) after loosening the screws (209).
- Unscrew union nut (215) from adapter (212) by turning anti-clockwise. To do so insert mandrel of diameter 10 mm into the side hole of the union nut and adapter.
- Remove thrust drive with lantern (204) after unscrewing the screws (200).
- Unscrew cylinder bolts (17).

Note

For renewal of the seals the description at item 2.2.1 and 2.2.2 applies accordingly.

2.2.6 thrust drive assembly

- Attach thrust drive and lantern
- Tighten cylinder bolts (17)
- Fit union nut (215) onto adapter (212) and tighten up to the stop using a mandrel
- Move valve sleeve to the "CLOSED" position using the electrical actuator
- Align zero indication on position indication plate (211) with the optical indication (213)
- Tighten screws (209)
- There is no need to adjust the end switches after maintenance.

2.2.7 screw torques M_A

DN	screw torque M_A in Nm									
	screw item no.									
	4	9	17	31	102	110	111a	200	205	215
50/100	160	10	80	3	10	45	3	80	160	30
80/150 100/200	240	25	80	3	10	45	3	80	160	30
150/300	560	80	350	8	45	45	3	350	-	-

2.2.8 lubricants

components	lubricant	RMG part no.
Spindle (105), ring (117), Feather key (115) (apply thick)	assembly paste	00 027 091
Valve sleeve (6), grease chambers (15), pressure bearing (112-114)	universal silicon	00 027 052
Sealing elements (apply thinly) all fastening screws and screwed pipe connections	silicon grease	00 027 081 (Tube 0,1 kg)

2.3.1.1 design with multiturn actuator

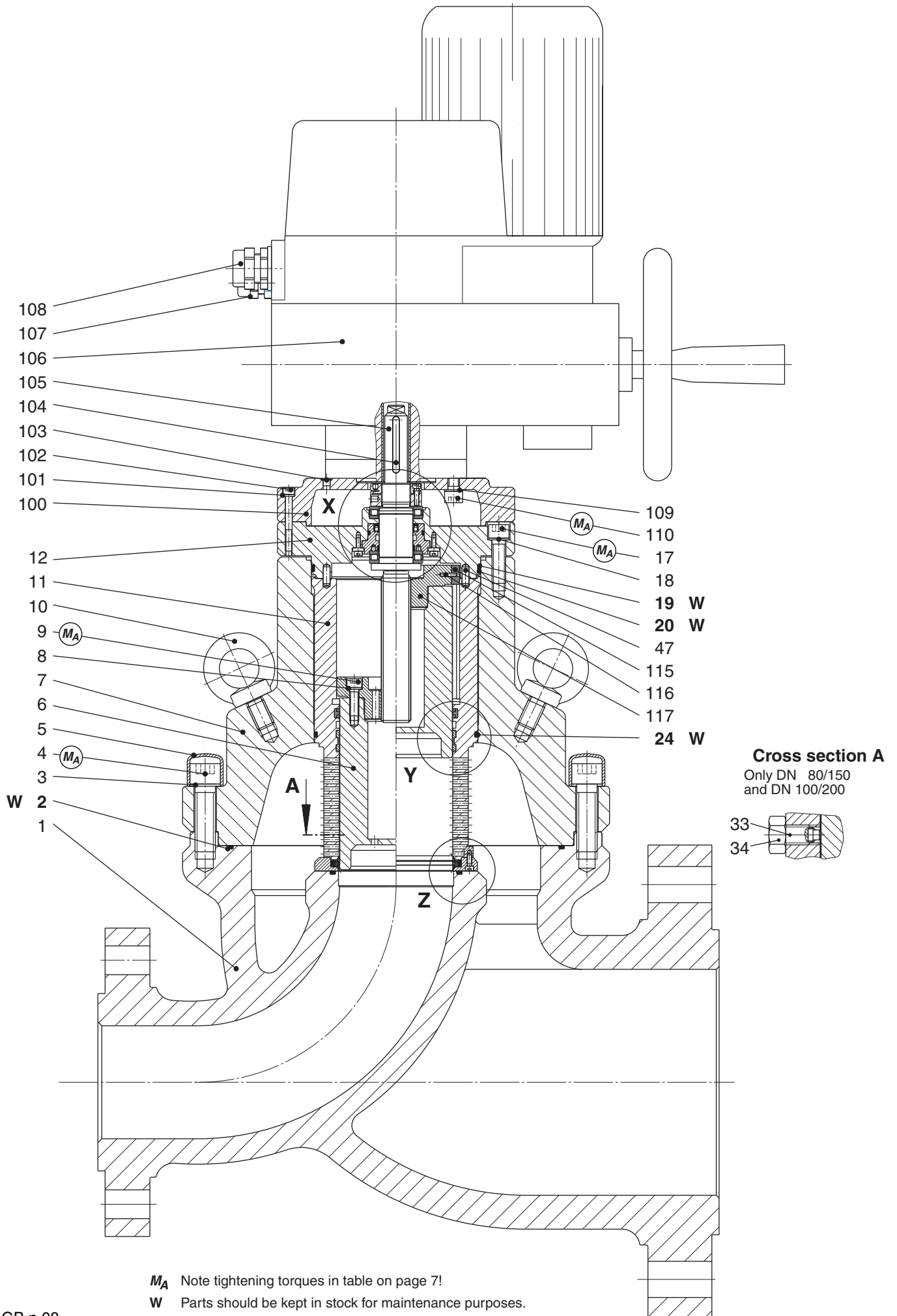

thrust drive detail

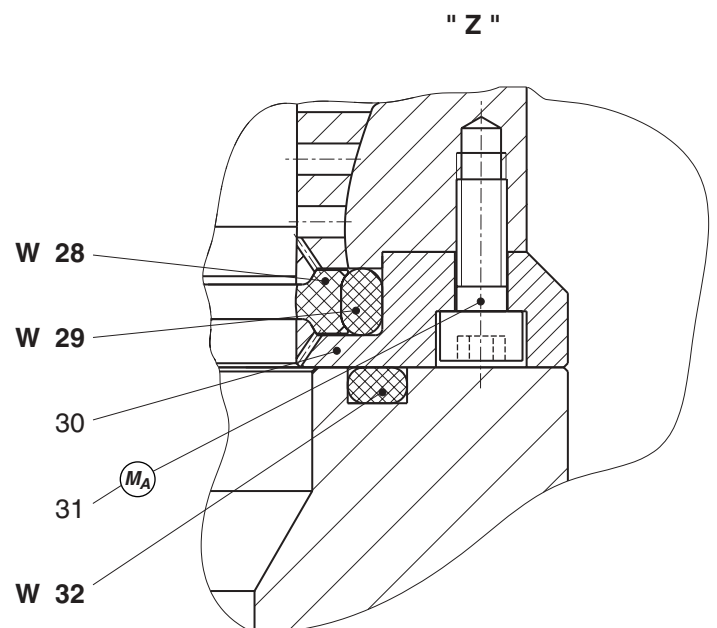
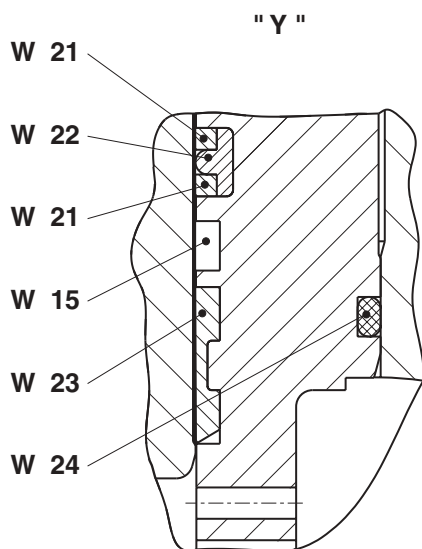
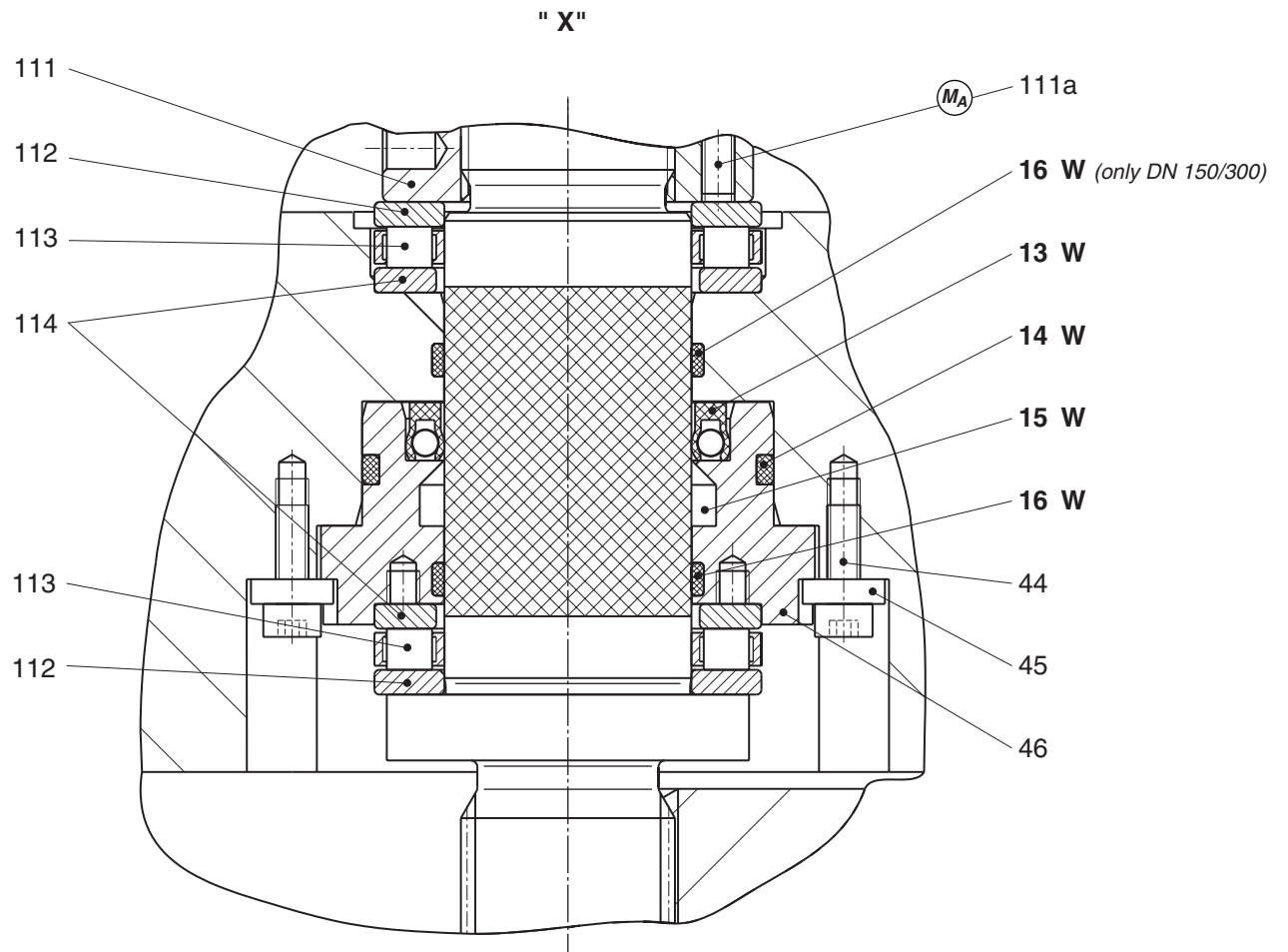

M_A Observe tightening torques in table on page 7!

W Parts should be kept in stock for maintenance purposes.

2.3.1.2 design with thrust drive

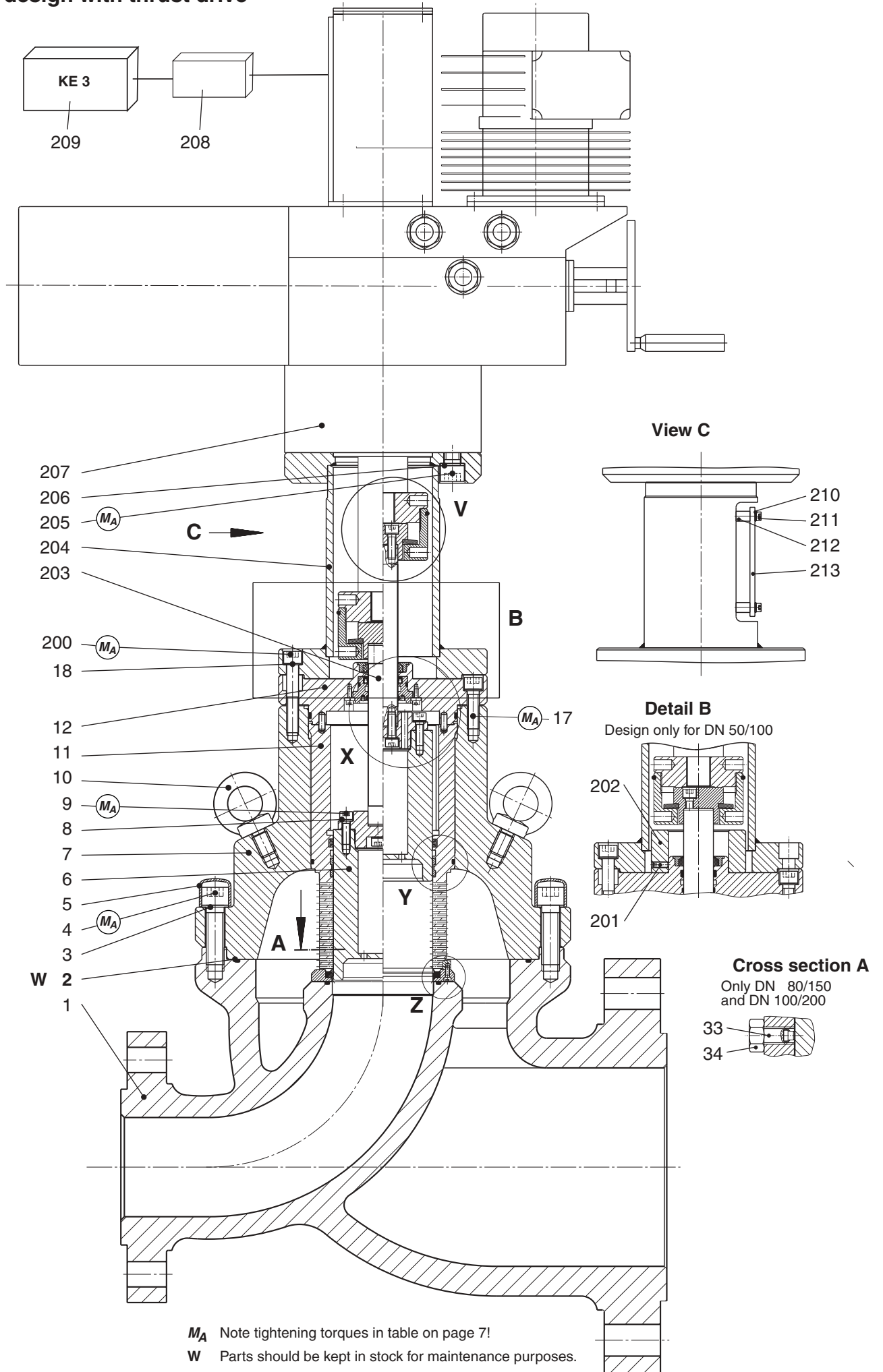

thrust drive detail

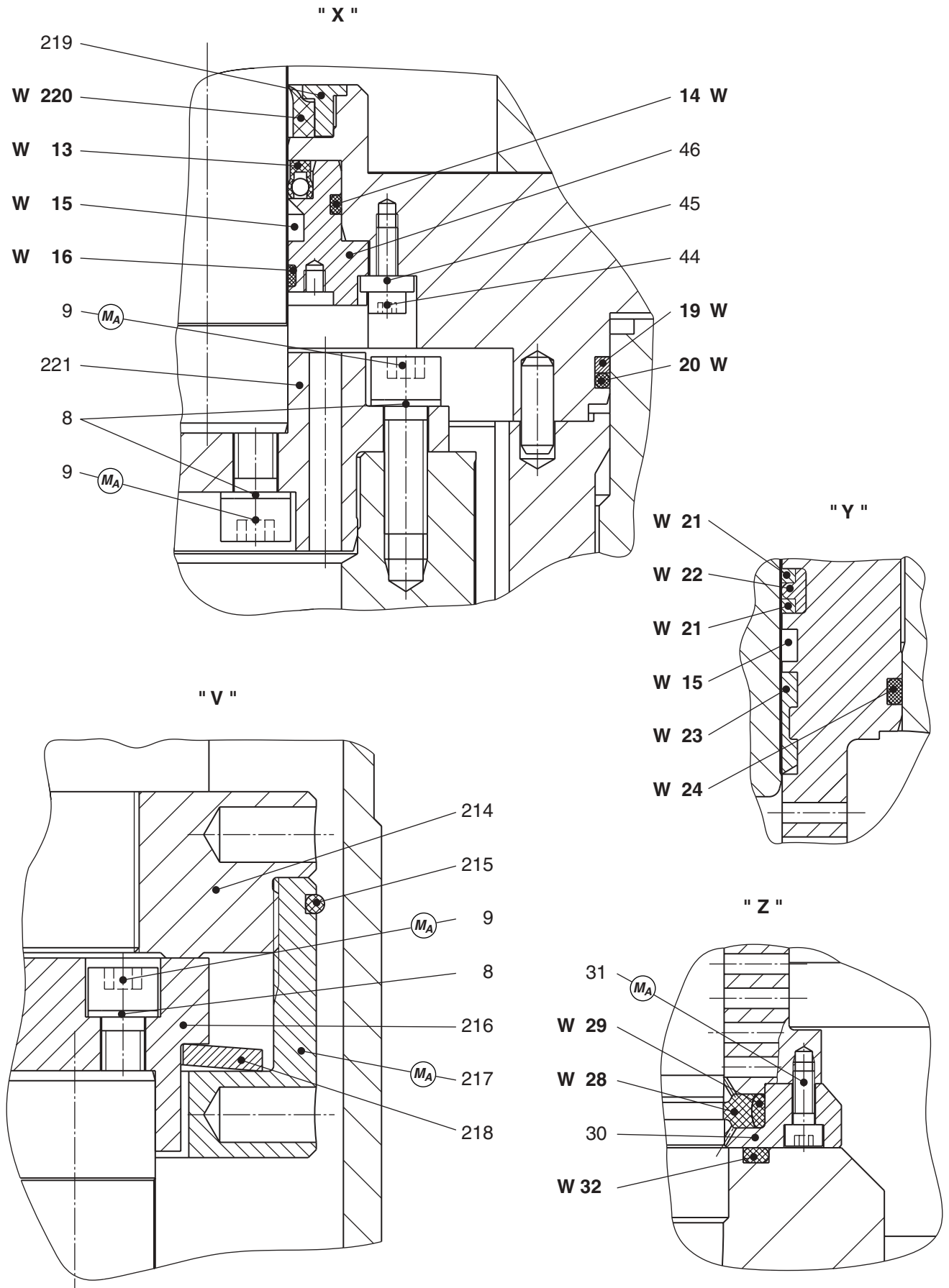

MA Observe tightening torques in table on page 7!

W Parts should be kept in stock for maintenance purposes.

2.3.2.1 main valve

item no.	designation	quant.	W	material	part number			
					DN 50/100	DN 80/150	DN 100/200	DN 150/300
1	Body (without SAV):							
1	PN 16	1		St	10 024 901	10 024 871	10 024 881	10 025 181
1	PN 40	1		St	10 024 902	10 024 872	10 024 882	10 025 182
1	ANSI 300 RF	1		St	10 024 903	10 024 873	10 024 883	10 025 183
1	ANSI 300 RJ	1		St	10 024 904	10 024 874	10 024 884	10 025 184
1	ANSI 600 RF	1		St	10 024 905	10 024 848	10 024 449	10 025 185
1	ANSI 600 RJ	1		St	10 024 906	10 024 876	10 024 886	10 025 186
1	PN 40 / ANSI 600 RF	1		St	10 024 907	10 024 877	10 024 887	10 025 187
1	ANSI 300 RF/ANSI 600RF	1		St	10 024 908	10 024 878	10 024 888	10 025 188
1	Body (with SAV):							
1	PN 16	1		St	10 025 141	10 025 151	10 025 161	
1	PN 40	1		St	10 025 142	10 025 152	10 025 162	
1	ANSI 300 RF	1		St	10 025 143	10 025 153	10 025 163	
1	ANSI 300 RJ	1		St	10 025 144	10 025 154	10 025 164	
1	ANSI 600 RF	1		St	10 025 145	10 025 155	10 025 165	
1	ANSI 600 RJ	1		St	10 025 146	10 025 156	10 025 166	
1	PN 40 / ANSI 600 RF	1		St	10 025 147	10 025 157	10 025 167	
1	ANSI 300 RF/ANSI 600RF	1		St	10 025 148	10 025 158	10 025 168	
2	o-ring	1	W	KG	00 020 286	00 020 977	00 020 977	00 020 418
3	Locking washer	10		St	00 014 116			
3	Locking washer	24		St		00 014 139	00 014 139	00 014 139
3	Locking washer	30		St				00 014 129
4	Cylinder bolt	10		St	00 010 555			
4	Cylinder bolt	24		St		00 010 601	00 010 601	00 010 601
4	Cylinder bolt	30		St				00 010 589
5	Cap	10		K	00 026 401			
5	Cap	24		K		00 026 402	00 026 402	
5	Cap	30		K				00 028 135
6	Valve sleeve	1		NSt	10 024 911	10 024 442	10 024 442	10 025 193
7	Body	1		St	10 024 916	10 024 440	10 024 440	10 025 189
8	Locking washer	8		St	00 014 111	00 014 112	00 014 112	00 014 114
9	Cylinder bolt	8		St	00 010 591	00 010 551	00 010 551	00 010 328
10	Ring bolt	2		St	00 010 021	00 010 003	00 010 003	00 010 047
11	Release sleeve	1		St	10 024 919	10 024 847	10 024 441	10 025 190
12	Plate	1		St	10 024 921	10 024 852	10 024 852	10 025 195
13	Seal	1	W	K	00 021 297	00 021 297	00 021 297	00 021 297
14	o-ring	1	W	KG	00 021 299	00 021 299	00 021 299	00 021 299
15	Lubricant		W		00 027 052	00 027 052	00 027 052	00 027 052

W Parts should be kept in stock for maintenance purposes

Material key

St ... steel	LM ... light alloy	AlBz ... aluminium bronze
NSt ... stainless steel	Ms ... brass	K ... plastic
FSt ... spring steel	Cu ... copper	KG ... rubbery plastic
NFSt ... stainless spring steel	Bz ... bronze	KGT ... rubbery plastic with coating
GS ... steel cast	GLM ... light alloy cast	KV ... rubber-like plastic material (NBR)
GGG ... cast iron with spheroidal graphite	GMS ... brass cast	KT ... special plastic (FP)
GZn ... zinc cast	GBz ... bronze cast	PGL ... plexiglass

item no.	description	amount	W	material	RMG part number			
					DN 50/100	DN 80/150	DN 100/200	DN 150/300
16	Guide band	1	W	K	00 021 194	00 021 194	00 021 194	
16	Guide band	2	W	K				00 021 194
17	Cylinder bolt	16		St	00 010 556	00 010 556	00 010 556	
17	Cylinder bolt	18		St				00 010 650
18	Locking washer	16		St	00 014 114	00 014 114	00 014 114	
18	Locking washer	18		St				00 014 124
19	Bearing ring	1	W	K		00 021 212	00 021 212	00 021 316
20	o-ring	1	W	KG	00 020 505	00 020 505	00 020 505	00 020 545
21	Bearing ring	2	W	K	00 021 053	00 021 059	00 021 059	00 021 063
22	T ring	1	W	K	00 020 989	00 021 044	00 021 044	00 020 997
23	Bearing ring	1	W	K	00 021 208	00 021 187	00 021 187	00 021 312
24	o-ring	1	W	KG	00 020 414	00 021 188	00 021 188	00 021 314
28	Sealing	1	W	K	00 021 211	00 021 182	00 021 182	00 021 313
29	o-ring	1	W	KG	00 021 210	00 020 268	00 020 268	00 020 630
30	Ring	1		NSt	18 356 793	18 356 792	18 356 792	10 025 191
31	Cylinder bolt	4		St	00 010 391	00 010 391	00 010 391	00 010 320
32	o-ring	1	W	KG	00 021 209	00 021 177	00 021 177	00 021 315
33	Guiding screw, complete.	4		St/K		10 024 448	10 024 448	
34	Hexagonal nut	4		St		00 005 559	00 005 559	
44	Cylinder bolt	2		St	00 010 197	00 010 497	00 010 497	00 010 497
45	Disc	2		St	10 024 854	10 024 854	10 024 854	10 024 854
46	Bush	1		St	18 356 737	18 356 737	18 356 737	18 356 737
47	Bolt	2		St	00 0,27 885	00 027 885	00 027 885	
47	Straight pin	2		St				00 017 275

2.3.2.2. design with multiturn actuator

item no.	description	amount	W	material	RMG part number			
					DN 50/100	DN 80/150	DN 100/200	DN 150/300
100	Cover	1		LM	10 024 431	10 024 431	10 024 431	10 025 197
101	Locking washer	8		St	00 014 111	00 014 111	00 014 111	
102	Cylinder bolt	8		St	00 010 422	00 010 422	00 010 422	
102	Cylinder bolt	9		St				00 010 400
103	Plug	3		K	00 026 544	00 026 544	00 026 544	00 026 663
104	Feather key	1		St	00 026 241	00 026 241	00 026 241	00 026 241
105	Spindle	1		NSt	10 024 432	10 024 432	10 024 432	10 027 017
106	AUMA multiturn actuator	1			00 024 388	00 024 388	00 024 388	00 024 388
106	EMG multiturn actuator	1			00 024 399	00 024 399	00 024 399	00 024 399
107	Screw connection PG 13,5 Ex	2		K	00 024 262	00 024 262	00 024 262	00 024 262
108	Screw connection PG 21 Ex	1		K	00 024 263	00 024 263	00 024 263	00 024 263
109	Locking washer	4		St	00 014 113	00 014 113	00 014 113	00 014 113
110	Cylinder bolt	4		St	00 010 207	00 010 207	00 010 207	00 010 274
111	Adjusting nut with	1		St	00 021 195	00 021 195	00 021 195	00 021 195
111a	Cylinder bolt	6						
112	Wave washer	2		St	00 021 197	00 021 197	00 021 197	00 021 197
113	Axial bearing	2		St	00 021 196	00 021 196	00 021 196	00 021 196
114	Outer washer	2		St	00 021 219	00 021 219	00 021 219	00 021 219
115	Feather key	1		St	00 027 879	00 027 879	00 027 879	00 028 134
116	Adapter sleeve	1		St	00 017 203	00 017 203	00 017 203	
116	Cylinder bolt	1		St				00 010 320
117	Ring	1		Ms	10 024 912	10 024 444	10 024 444	
117	Spindle nut	1		Ms				10 025 194

2.3.2.3 design with thrust drive

item no.	description	amt.	W	material	RMG part number		
					DN 50/100	DN 80/150	DN 100/200
200	Cylinder bolt	4		St	00 010 594	00 010 594	00 010 594
201	Threaded bolt	1		St	00 012 224		
202	Arresting tube	1		St	19 083 686		
203	Thrust rod	1		St	10 024 856	10 024 856	10 024 856
204	Lantern	1		St	10 024 862	10 024 862	10 024 862
205	Cylinder bolt	4		St	00 010 394	00 010 394	00 010 394
206	Locking washer	4		St	00 014 116	00 014 116	00 014 116
207	Thrust drive	1			00 024 350	00 024 350	00 024 350
208	Capacitor	1			81 100 191	81 100 191	81 100 191
209	Power control KE 3	1			81 100 190	81 100 190	81 100 190
210	Disk	4		LM	00 014 150	00 014 150	00 014 150
211	Cylinder bolt	4		St	00 010 476	00 010 476	00 010 476
212	Bush	4		NSt	19 083 682	19 083 682	19 083682
213	Position indication plate	1		PG	19 083 685	19 083 681	19 083 681
214	Adapter	1		NSt	19 083 672	19 083 672	19 083 672
215	o-ring	1		KG	00 021 218	00 021 218	00 021 218
216	Ring	1		Ms	19 083 673	19 083 673	19 083 673
217	Union nut	1		St	19 083 674	19 083 674	19 083 674
218	Spring washer	1		St	00 027 898	00 027 898	00 027 898
219	Scraper ring	1		LM	19 083 675	19 083 675	19 083 675
220	Scraper	1		KG	00 021 213	00 021 213	00 021 213
221	Ring	1		NSt	19 083 670	19 083 670	19 073 670

2.3.3 spare parts for maintenance works

item no.	description	amount	RMG part number			
			DN 50/100	DN 80/150	DN 100/200	DN 150/300
2	o-ring	1	00 020 286	00 020 977	00 020 977	00 020 418
13	Seal	1	00 021 297	00 021 297	00 021 297	00 021 297
14	o-ring	1	00 021 299	00 021 299	00 021 299	00 021 299
15	Lubricant		00 027 052	00 027 052	00 027 052	00 027 052
16	Guide band	1	00 021 194	00 021 194	00 021 194	
16	Guide band	2				00 021 194
19	Bearing ring	1		00 021 212	00 021 212	00 021 316
20	o-ring	1	00 020 505	00 020 505	00 020 505	00 020 545
21	Bearing ring	2	00 021 053	00 021 059	00 021 059	00 021 063
22	T ring	1	00 020 989	00 021 044	00 021 044	00 020 997
23	Guide ring	1	00 021 208	00 021 187	00 021 187	00 021 312
24	o-ring	1	00 020 414	00 021 188	00 021 188	00 021 314
28	Sealing	1	00021 211	00 021 182	00 021 182	00 021 313
29	o-ring	1	00 021 210	00 020 268	00 020 268	00 020 630
32	o-ring	1	00 021 209	00 021 177	00 021 177	00 021 315

3. integrated safety cut-off valve (SSV) - system RMG 711

3.1 special operating notes

opening the safety shut-off valve (SSV)

- To open the SSV control element, insert the handlebar (712) into the corresponding hole in the disc (734) and turn.

Note

For the control devices K 10a or K 11a the SSV control element can only be opened if the control devices have previously engaged.

- The control devices K 10a and K 11a are engaged by pulling on the switch rod. To do so, screw the inverted cap onto the switch rod (see also 672.20).
- The control devices K 10a and K 11a have been fitted with underpressure cutout. They can only engage if the pressure at the measuring location equals the operating pressure.

test switching with control devices K 10a and K 11a



Test switching is only permitted, if the control devices K 10a and K 11a have been fitted to the tripping device body (710), otherwise mechanical damage can result.

3.2 special maintenance notes

3.2.1 tripping device

- Prior to disassembly of the switch bearing (707) the pressure piece (768) must be unscrewed from the tripping device body (710).
- When fitting the switch bearing it should be noted:
 - An angled double stop of the switch bearing must point towards the pressure piece (768). (see 3.3.1 SSV - System cross section A-A)
 - The sliding ring (721) must be positioned below the switch bearing.

3.2.2 main valve

valve flap (753)

- For a visual check of the valve flap o-ring (754) remove cover (747) and open SAV (engage). When inserting a new greased o-ring (774) into the groove of the valve flap (753) the o-ring should first be pressed into the groove at 3 - 4 locations distributed equally around the circumference of the groove. Only then should the o-ring be pressed in completely. After separating the valve flap from the valve flap lever (750) the locking nut (752) must be tightened with the prescribed torque and must be further secured using the split pin (773).

closing springs (731)

- 2 retaining grooves for the closing springs have been cast into the spring housing (733). The grooves are necessary for the different acceptance of the closing springs in the design variations "right-hand operation" or "left-hand operation".
- During installation the closing springs must first be placed in the spring housing (733). The positioning of the springs as per figure 1 and 2 must be observed.
- The closing springs are pretensioned correctly when all 4 fastening screws (732) can be fitted into the housing (approx half a turn of the spring housing). The valve flap must be in the closed position.

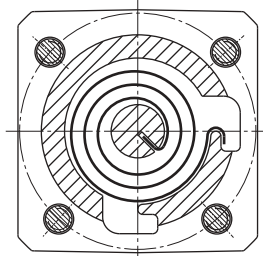

Figure 1
Closing spring fitting position for "right-handed" operation

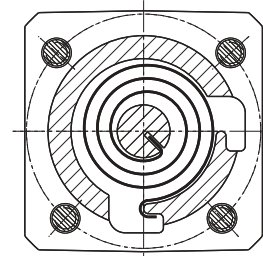

Figure 2
Closing spring fitting position for "left-handed" operation

3.2.3 screw tightening torques M_A

size DN	tightening torque M_A in Nm				
	screw item no.				
	708	732	745	752	800
50/100	8	8	75	12	-
80/150	20	20	160	40	10
100/200	20	20	160	40	10

3.2.4 lubricants

components	lubricants	RMG part no.
all o-rings, sliding guides, sliding surfaces, and switching elements, all fastening screws and screwed pipe connections	silicon grease	00 027 081 (tube 0.1 kg)
Thread of manual release	assembly paste	00 027 091

3.3.1. spare parts drawing

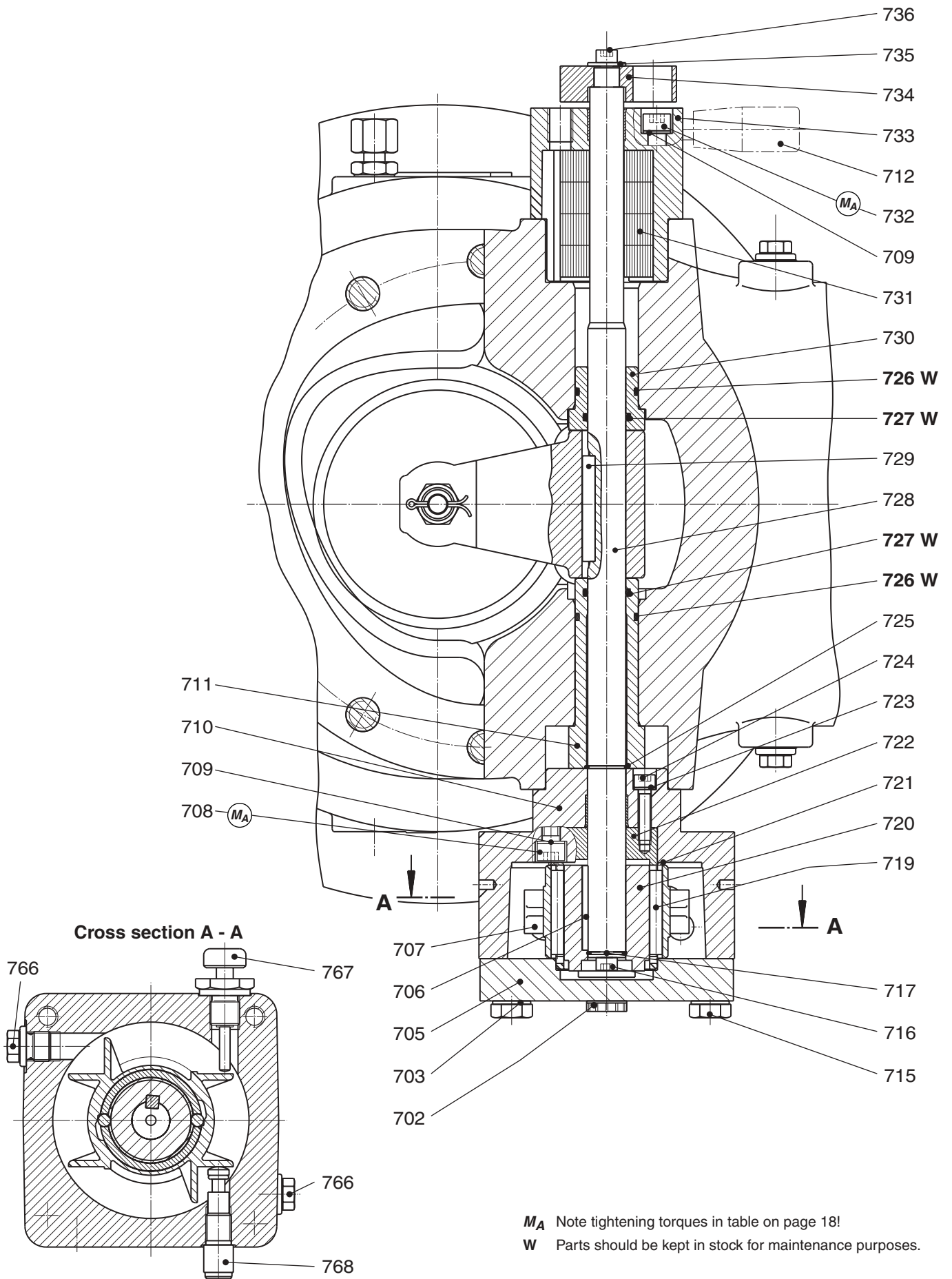

DN 50/100
Design until 1/99

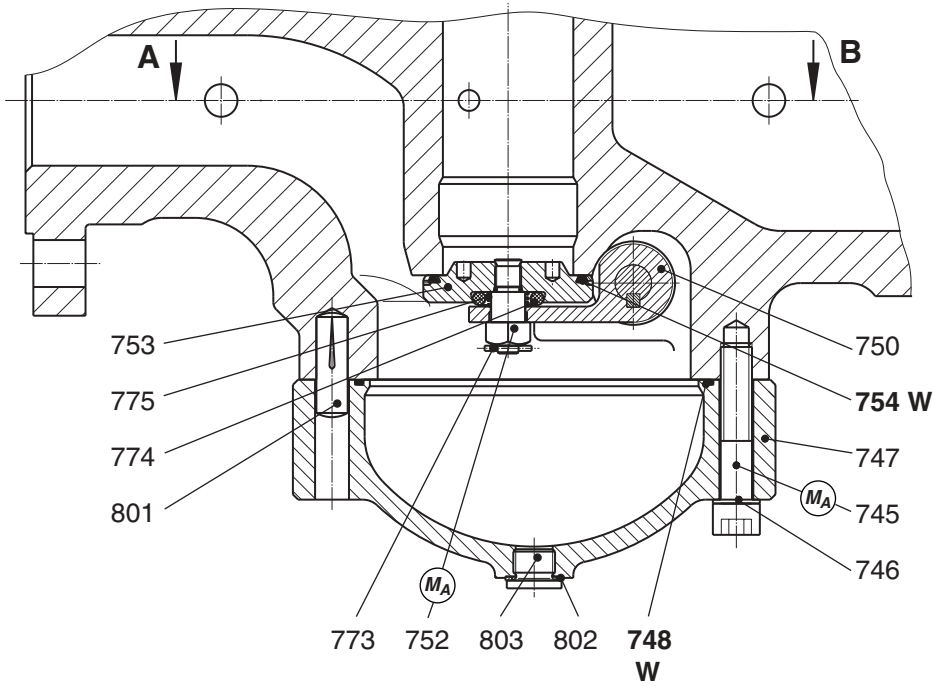

Cover design
until 3rd quarter 1996

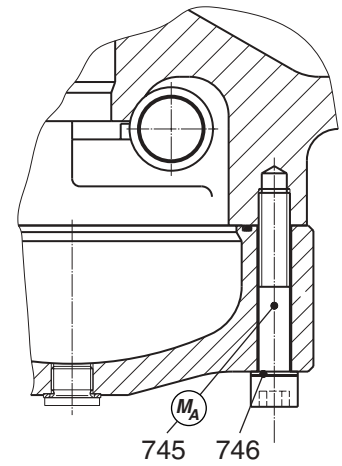

DN 80/150 and DN 100/200
Design from 06/97

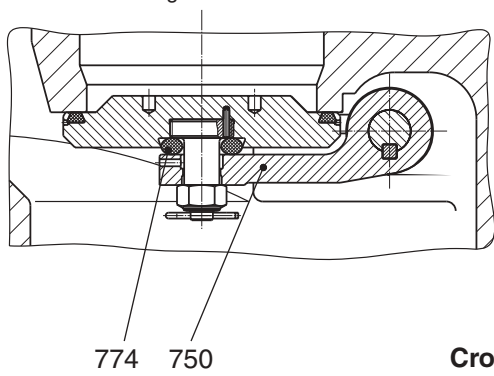

DN 50/100
Design from 01/99

DN 80/150 and DN 100/200
Design from 01/2000

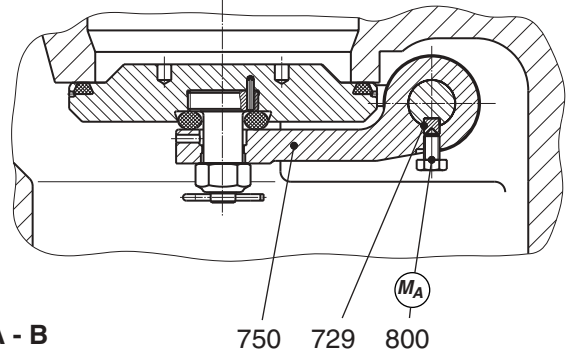

Cross section A - B

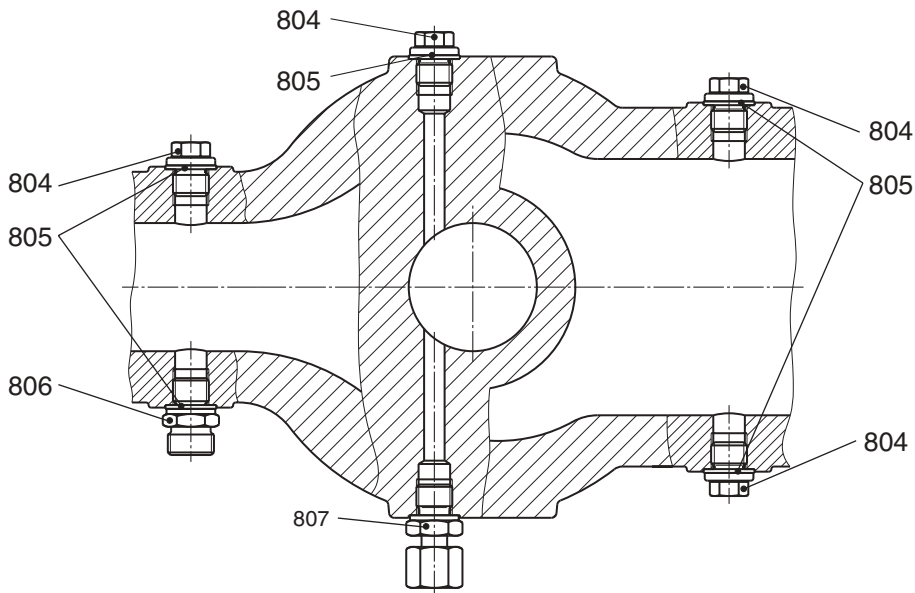

MA Observe tightening torques in table on page 18!

W Parts should be kept in stock for maintenance purposes.

**DN 50/100
push-button valve RMG 913a**

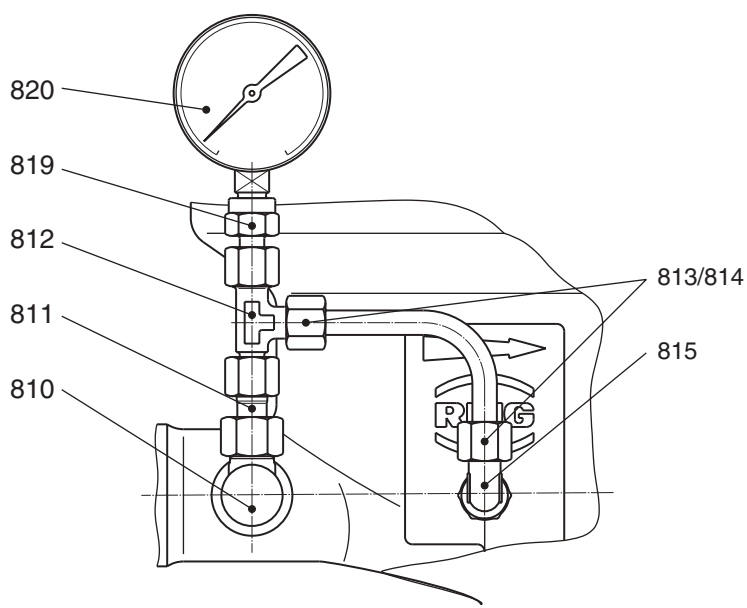

**DN 80/150 and 100/200
push-button valve RMG 910a**

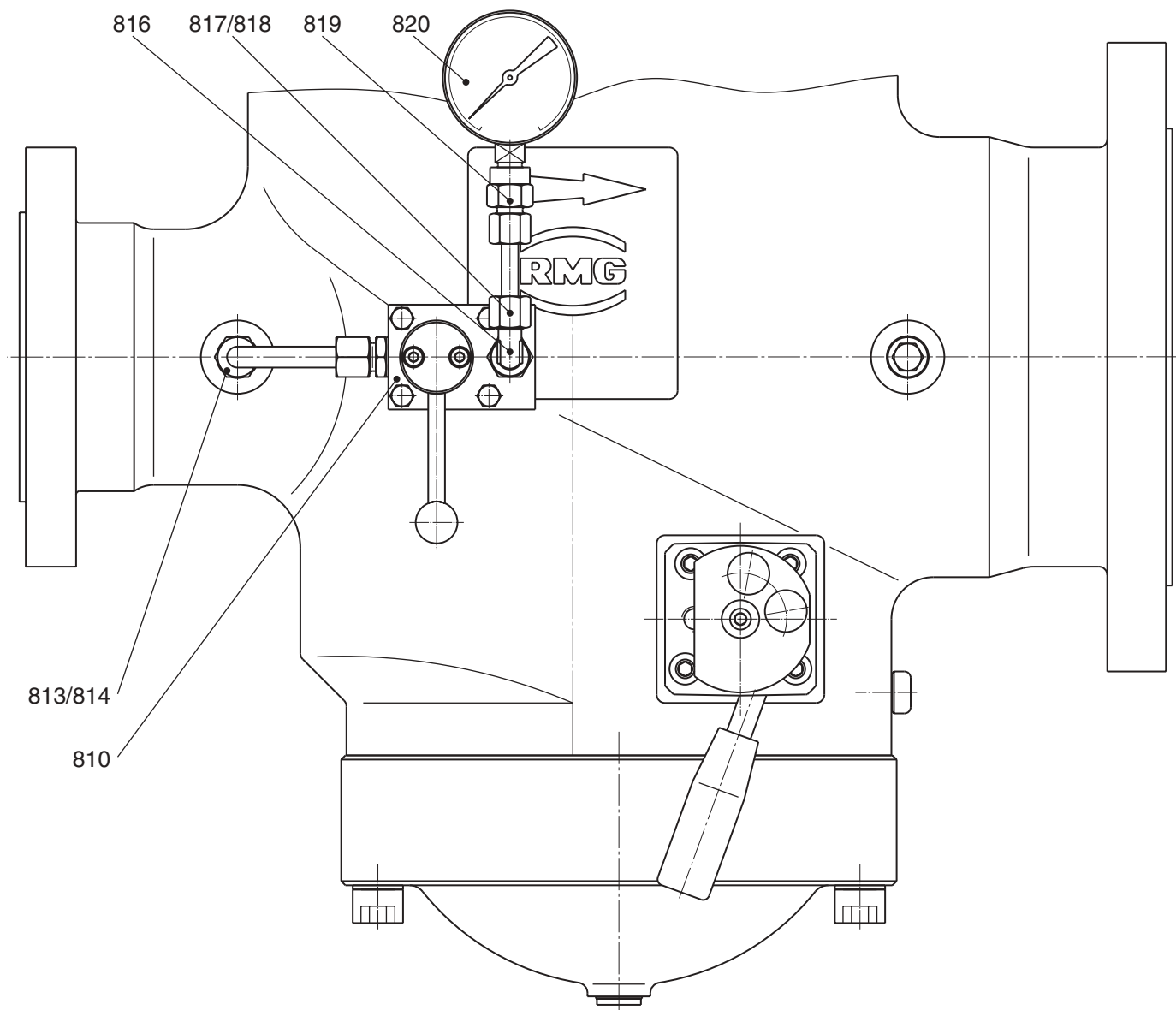

3.3.2 spare parts list

item no.	description	amt.	W	material	RMG part number		
					DN 50/100	DN 80/150	DN 100/200
702	Plug	1		K	00 026 550	00 026 550	
703	Disk	4		St	00 008 281	00 014 106	
705	Switch housing cover	1		LM	10 022 323	10 022 423	
706	Feather key	1		St	00 026 255	00 026 240	
707	Switch bearing	1		NSt	10 022 327	10 022 427	
708	Cylinder bolt	4		St	00 010 120	00 010 379	
709	Locking washer	8		FSt	00 014 111	00 014 112	
710	Switch housing, complete	1		GLM/K	10 022 326	10 022 426	
711	Bearing bush	1		Ms	10 022 318	10 024 638	
712	Handlebar, complete	1		NSt/K/KG	10 024 536	10 024 636	
715	Hexagonal screw	4		St	00 010 083	00 003 873	
716	Cylinder bolt	1		St	00 008 177	00 008 177	
717	Disc	1		LM	10 001 186	10 001 386	
719	Switch pin	2		St	00 027 646	00 027 301	
720	Arresting sleeve, complete	1		NSt/SF	10 022 332	10 022 432	
721	Sliding ring	1		KT	00 021 140	00 021 112	
722	Guiding bush	1		NSt	10 022 330	10 022 430	
723	Locking washer	3		FSt	00 014 118	00 014 111	
724	Cylinder bolt	3		St	00 010 561	00 010 150	
725	Circlip	1		FSt	00 019 110	00 019 112	
726	O ring	2	W	KG	00 020 227	00 020 235	
727	O ring	2	W	KG	00 021 142	00 020 607	
728	Valve flap shaft	1		NSt	10 022 317	10 024 637	
729	Feather key	1		St	00 026 256	10 024 646	
730	Bearing bush	1		Ms	10 022 319	10 022 369	
731	Flat spiral spring	3		NSt	10 022 336		
731	Flat spiral spring	4		NSt		10 022 436	
732	Cylinder bolt	4		St	00 010 549	00 010 428	
733	Srping housing, complete1			GLM/K	10 024 535	10 024 635	
734	Disk, complete	1		LM/St	10 024 540	10 024 640	
735	Disk	1		St	00 014 082	00 014 137	
736	Cylinder bolt	1		St	00 010 618	00 008 177	
745	Cylinder bolt M12x60	12		St	00 010 625		
745	till 3rd quarter 1996 M12x70	12		St	00 010 594		
745	Cylinder bolt M16x80	12		St		00 010 626	
745	till 3rd quarter 1996 M16x110	12		St		00 010 543	
746	Locking washer	12		FSt	00 014 114	00 014 116	
747	Cover	1		St	10 024 541	10 024 641	
748	O ring	1	W	KG	00 020 427	00 020 573	
750	Valve flap lever	1		St	10 022 313	10 024 633	
752	Locking nut	1		St	00 013 200	00 013 202	
753	Valve flap, complete	1		Ms/NSt/St	10 022 312	10 022 407	
754	O ring	1	W	KG	00 020 458	00 020 313	

item no.	description	quant.	W	material	RMG part number		
					DN 50/100	DN 80/150	DN 100/200
766	Screw plug	2		St	00 026 175		00 026 175
767	Manual release, complete	1		Al/FSt/NSt	10 022 340		10 022 440
768	Elastic pressure piece	1		Ms/NSt	10 022 391		10 022 391
773	Split pin	1		St	00 015 000		00 015 007
774	o-ring	1		KG	00 021 334		00 021 287
775	Pressure spring	1		FSt	10 018 394		
800	Hexagonal screw	2		St			10 024 648
801	Half length grooved pin	2		St	00 017 200		00 017 200
802	Sealing ring	1		LM	00 018 694		00 018 694
803	Screw plug	1		St	00 010 381		00 010 381
804	Screw plug	4		St	00 026 175		00 026 175
805	Sealing ring	5		LM	00 018 842		00 018 842
806	Muff	1		St	00 030 074		00 030 111
807	Muff	1		St	00 030 111		00 030 023
810	Push button valve	1			10 005 200		89 100 210
811	Screw connection	1		St	00 031 817		
812	Adapter	1		St	00 030 622		
813	Union nut	3		St	00 030 803		
813	Union nut	1		St			00 030 803
814	Cutting ring	3		St	00 030 903		
814	Cutting ring	1		St			00 030 903
815	Screwed connection	1		St	00 031 207		
816	Screwed connection	1		St			00 031 206
817	Union nut	1		St			00 030 801
818	Cutting ring	1		St			00 030 901
819	Screwed nut	1		St	00 031 810		00 031 811
820	Pressure gauge, optionally:						
820	Pressure gauge 0 to 25 bar	1		NSt/Ms	00 026 248		00 026 248
820	Pressure gauge 0 to 40 bar	1		NSt/Ms	00 026 282		00 026 282
820	Pressure gauge 0 to 60 bar	1		NSt/Ms	00 026 283		00 026 283
820	Pressure gauge 0 to 100 bar	1		NSt/Ms	00 026 285		00 026 285

3.3.3 spare parts drawing accessories

electromagnetic tripping with current supply

electromagnetic tripping with current loss

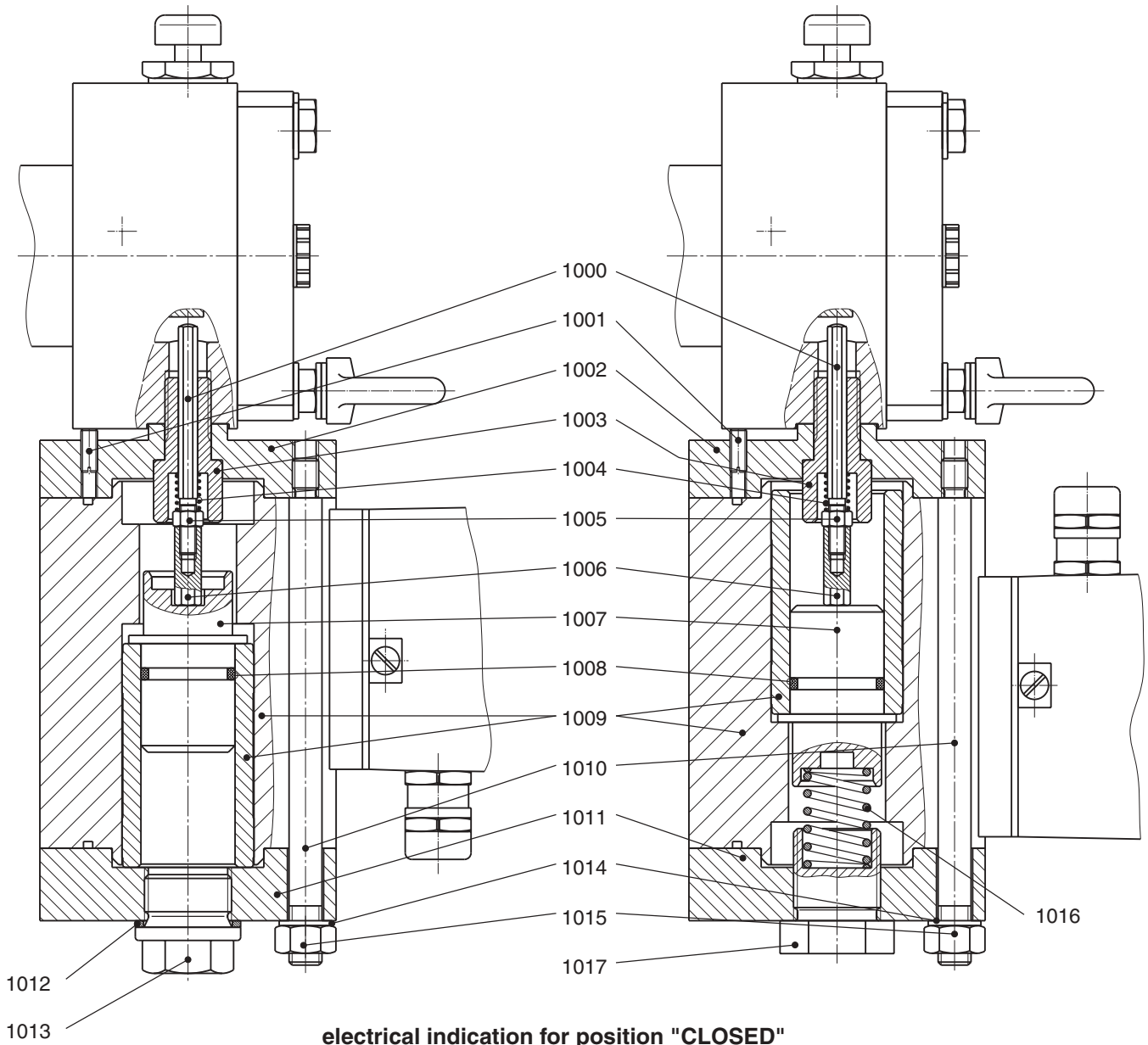

electrical indication for position "CLOSED"

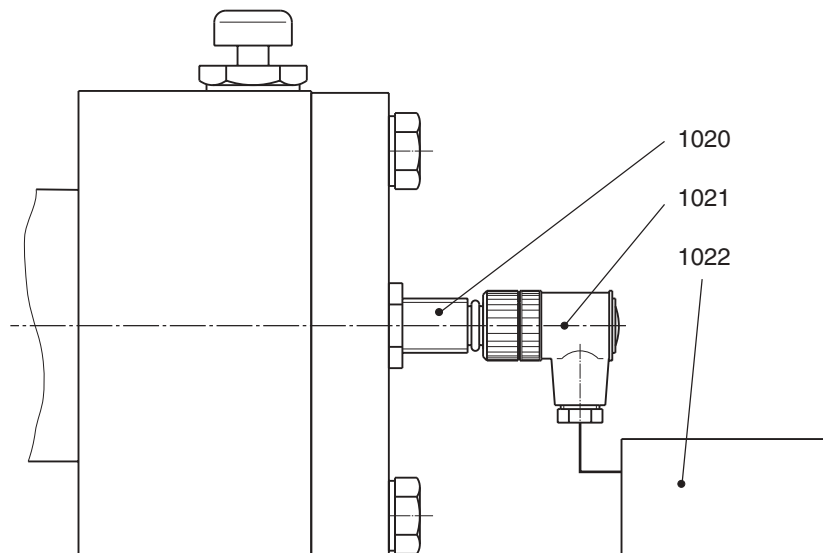

3.3.4 spare part lists accessories

item no.	description	amt.	W	material	RMG part number
1000	Switch rod, optionally for:				
1000	RMG 711 DN 25 and DN 50	1		NSt	10 022 568
1000	RMG 503 DN 25/50 and DN50/100	1		NSt	10 022 568
1000	RMG 530 DN 50/100	1		NSt	10 022 568
1000	RMG 711 DN 80 and DN 100	1		NSt	10 022 573
1000	RMG 503 and RMG 530 DN 80/150 and DN 100/200	1		NSt	10 022 573
1000	RMG 711 DN 150	1		NSt	10 022 578
1001	Threaded bolt	1		St	00 008 486
1002	Connection flange	1		LM	10 022 582
1003	Guiding screw	1		NSt	10 001 811
1004	Pressure spring	1		SF	10 001 183
1005	Hexagonal nut	1		St	00 003 020
1006	Adjusting nut	1		Ms	10 001 864
1007	Bush	1		LM	10 022 584
1008	o-ring	1		KG	00 020 327
1009	Magnet	1			00 024 436
1010	Threaded bolt	4		NSt	10 022 585
1011	Cover	1		LM	10 022 583
1012	Sealing ring	1		LM	00 018 706
1013	Screw plug	1		St	00 026 523
1014	Locking washer	4		SF	00 014 113
1015	Hexagonal nut	4		St	00 005 692
1016	Pressure spring	1		SF	00 028 067
1017	Screw plug	1		Ms	10 022 586
1020	Proximity switch	1			00 024 160
1021	Socket	1			00 024 099
1022	Isolator, optionally:				
1022	for 1 proximity switch (230V AC)	1			00 024 402
1022	for 2 proximity switches (230V AC)	1			00 024 403

3.3.5 spare parts for maintenance work

item no.	description	amount	RMG part number			
			DN 50/100	DN 80/150	DN 100/200	DN 150/300
726	O ring	2	00 020 227	00 020 235	00 020 235	
727	O ring	2	00 021 142	00 020 607	00 020 607	
748	O ring	1	00 020 427	00 020 573	00 020 573	
754	O ring	1	00 020 458	00 020 313	00 020 313	

We supply you with products for gas pressure regulation:



RMG REGEL + MESSTECHNIK GMBH

Osterholzstrasse 45, D-34123 Kassel, Germany
Telephone (+49) 561 5007-0 • Fax (+49) 561 5007-107
gas pressure regulators and safety devices



RMG-GASELAN Regel + Messtechnik GmbH

Julius-Pintsch-Ring 3, D-15517 Fürstenwalde, Germany
Telephone (+49) 3361 356-60 • Fax (+49) 3361 356-836
gas pressure regulating equipment, displacement meters, complete stations



Bryan Donkin RMG Gas Controls Ltd.

Enterprise Drive, Holmewood, Chesterfield S42 5UZ, England
Telephone (+44) 1246 501-501 • Fax (+44) 1246 501-500
gas pressure regulating equipment, below ground gas control modules



Bryan Donkin RMG Co. of Canada Ltd.

50 Clarke Street South, Woodstock, Ontario N4S 7Y5, Canada
Telephone (+1) 519 5398531 • Fax (+1) 519 5373339
domestic regulators and safety devices

The other RMG Companies:



RMG Messtechnik GmbH

Otto-Hahn-Strasse 5, D-35510 Butzbach, Germany
Telephone (+49) 6033 897-0 • Fax (+49) 6033 897-130
turbine meters, vortex meters, correctors, flow computers, odorizers



Karl Wieser GmbH

Anzinger Strasse 14, D-85560 Ebersberg, Germany
Telephone (+49) 8092 2097-0 • Fax (+49) 8092 2097-10

Betriebsstelle Beindersheim

Heinrich-Lanz-Strasse 9, D-67259 Beindersheim/Pfalz, Germany
Telephone (+49) 6233 3762-0 • Fax (+49) 6233 3762-40
data logging, monitor systems, danger alarm systems



WÄGA Wärme-Gastechnik GmbH

Osterholzstrasse 45, D-34123 Kassel, Germany
Telephone (+49) 561 5007-0 • Fax (+49) 561 5007-207
design and assembly of gas pressure regulating and metering stations



ZUG GAZOMET Sp. z o.o.

ul. Sarnowska 2, 63-900 Rawicz, Polen
Telephone (+48) 65 546 24 01 • Telefax (+48) 65 546 24 08
ball valves, gas pressure regulating equipment and stations, steel construction

The RMG Group of Companies on the internet: <http://www.rmg.de>

Serving the Gas Industry - WORLDWIDE



We reserve the right for technical changes