

Gas Pressure Regulator RMG 330



Operation and Maintenance, Spare Parts

For integrated safety cut-off unit please refer to technical leaflet 720.20

330.20

edition 11/1995

Serving the Gas Industry - WORLDWIDE



1. General

The "General Description 330.00" for the gas pressure regulator of series RMG 330 contains technical data, versions and dimensions. The spare parts are described in the following brochures:

Safety shut-off valve 720:	General description	720.00
	Operation and maintenance, Spare parts	720.20

Our brochure "General Operating Instructions for Gas Pressure Regulators and Safety Devices" will be useful to fit the valve into the line, put into the line, put into service and find faults that might disturb the operation.

The construction, set-up, supervision and maintenance of gas pressure stations are subject to special technical rules which should be strictly observed, in particular those given by the DVGW-Worksheets G 490, G 491 and G 495.

The frequency of periodical maintenance of gas pressure regulator RMG 330 should be determined according to the prevailing conditions and the type and composition of the gaseous medium.

We, therefore, abstain from imposing any fixed intervals and would rather refer to the recommendations given by the DVGW-Worksheets G 495.

For maintenance all parts are to be cleaned and subjected to a thorough visual inspection. A visual inspection should not be omitted when the course of operation or functional tests have shown lack of regulating accuracy.

Particular care should be given to the checking of sealings and diaphragms, as well as carrying and moving parts. Damaged parts should be replaced by new ones.

The item numbers referred to in the maintenance instructions are identical with those of spare parts drawings and spare parts lists.

We recommend to keep all parts that are specially marked in the spare parts lists in stock for prompt maintenance availability.

2. Special Operating Instructions

Change of the outlet pressure range

For removing a setpoint spring from measuring unit size 2 proceed as follows:

- release setpoint spring (224)
- loosen screws (221)
- press locking plate (222) into spring housing above the diaphragm vase (232)
- remove half-round rings (253)

3. Special Maintenance Operations

O-ring (157, 241, 309)

Attention! These o-rings should be fitted unlubricated, as they serve only as locking rings for the reducing adapter (155, 239, 305).

O-rings (46, 47)

When fitting the diaphragm assembly and the adapting part of the o-ring is to be positioned as shown below:

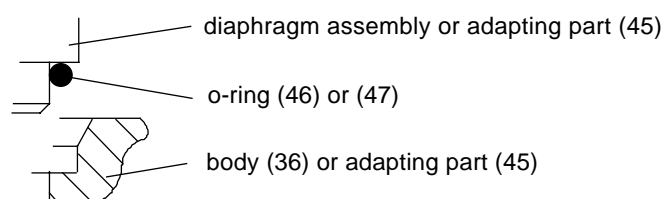

Compensating diaphragm (118,168, 243, 308)

Make sure to fit the compensation diaphragm in the correct mounting position

see page 10

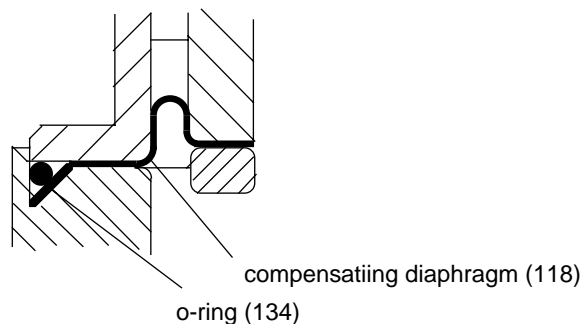

see pages 13, 17, 20

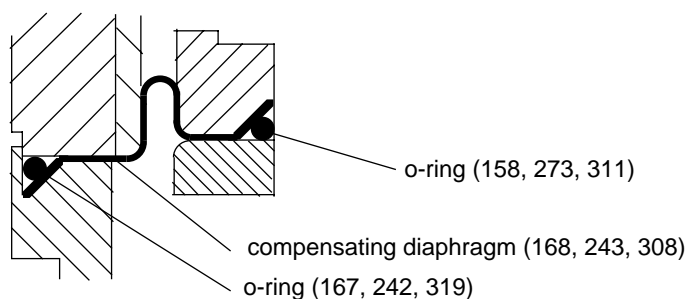

Valve stem (121, 172, 204, 274, 321)

In order to avoid any diaphragm distortions when loosening or tightening the screws (163, 277, 325) or nuts (108, 141, 228), it is necessary to safeguard the valve stem from distortion. To this effect the valve stem (121) has been provided with a lateral arresting bore, whereas the valve stem (172, 204, 274, 321) have been machined with a key guide surface.

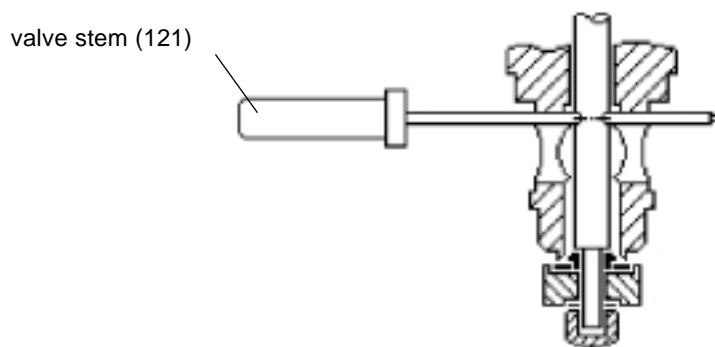

3.1 Suite to "Special Maintenance Operations"

Cylinder screw (163, 277, 325)



The cylinder screw is provided with a longitudinal bore for pressure compensation and should, therefore, not be replaced by a cylinder screw of the conventional type.

Sealing (123,161, 248) for valve diameter 33, 25, 31

According to kinds of gas used, several sealing materials can be used. From November 1994 the material NBR was replaced by viton. It is recommended specially by using L-gas to used sealings out of viton for maintenance works.

Valve plate (124, 162, 249, 315)

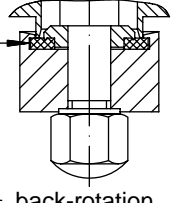
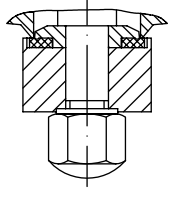
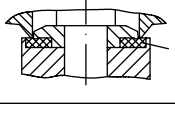
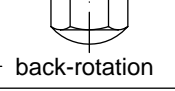
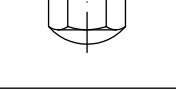
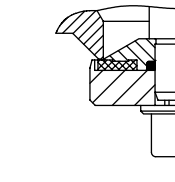
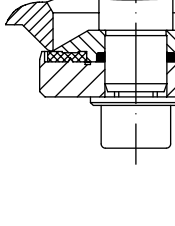
The valve plate design has been changed several times for deliveries

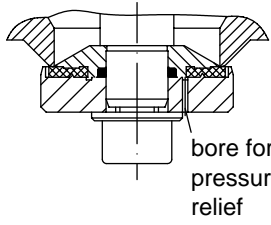
		valve plate design delivered			
		up to Sept. 1987	up to March 1992	from April 1992	from August 1995
valve seat - Ø in mm	20			 sealing vulcanized	
	33	 back-rotation			
	25			 bore for pressure relief	
	31				
	41				
	50				
	60				
	80				
	100				 bore for pressure relief

The valve plate dia. Ø 20 is now provided with a sealing vulcanized to the plate; the valve plate dias. Ø 25, 31, 33, 41, 50, 60, 80 and 100 are provided with an additional bore for pressure relief.

We recommend to fit new design valve plate into old regulators.
Regulators with valve seat dias. Ø 20 or 33 supplied before September 1987 need not to be changed.

Torque

item no.	torque M_A in Nm
170, 245	5
113, 153, 159, 238, 246, 312	10
150, 235	12
141	15
194, 228	18
163, 277, 317, 320	20
30, 38, 40, 56, 302, 325	40
226	5 (only for fitting of arresting tube)
108	10 (see p. 9)
	18 (see p. 12)
132	15 (see p. 9)
	20 (see p. 12)

Lubricants

part (to be greased slightly)	lubricant	RMG part-no.
all o-rings (except items 157, 241, 309)	silicone grease	00 027 081
all sliding surfaces		
fixed end and loop areas of working diaphragm (122, 233)		
all fastening and pipe screws	high duty grease	00 027 058

Screw locking

part	screw locking	RMG part-no.
cap nut (141) cylinder screw (163, 277, 325) adjusting piece (226) (only for valves with arresting tubes fitted)	LOCTITE	00 026 688

Adjusting tools

regulator diaphragm assy.	adjusting tool			
	for setpoint adjusting screw	no.	description	RMG part-no.
size 1	103 for $W_h \leq 0,5$ bar for $W_h \geq 0,45$ bar 106	W 1	key DIN 659-41	00 026 502
		W 2	p_a - adjusting key	10 004 911
		W 5	screw driver DIN 911 - 14	00 026 266
size 2	251	W 3	open-jawed or ring spanner SW 32	

4. Spare Parts
Spare Parts Drawing RMG 330 DN 25, DN 50
Diaphragm Assembly size 1

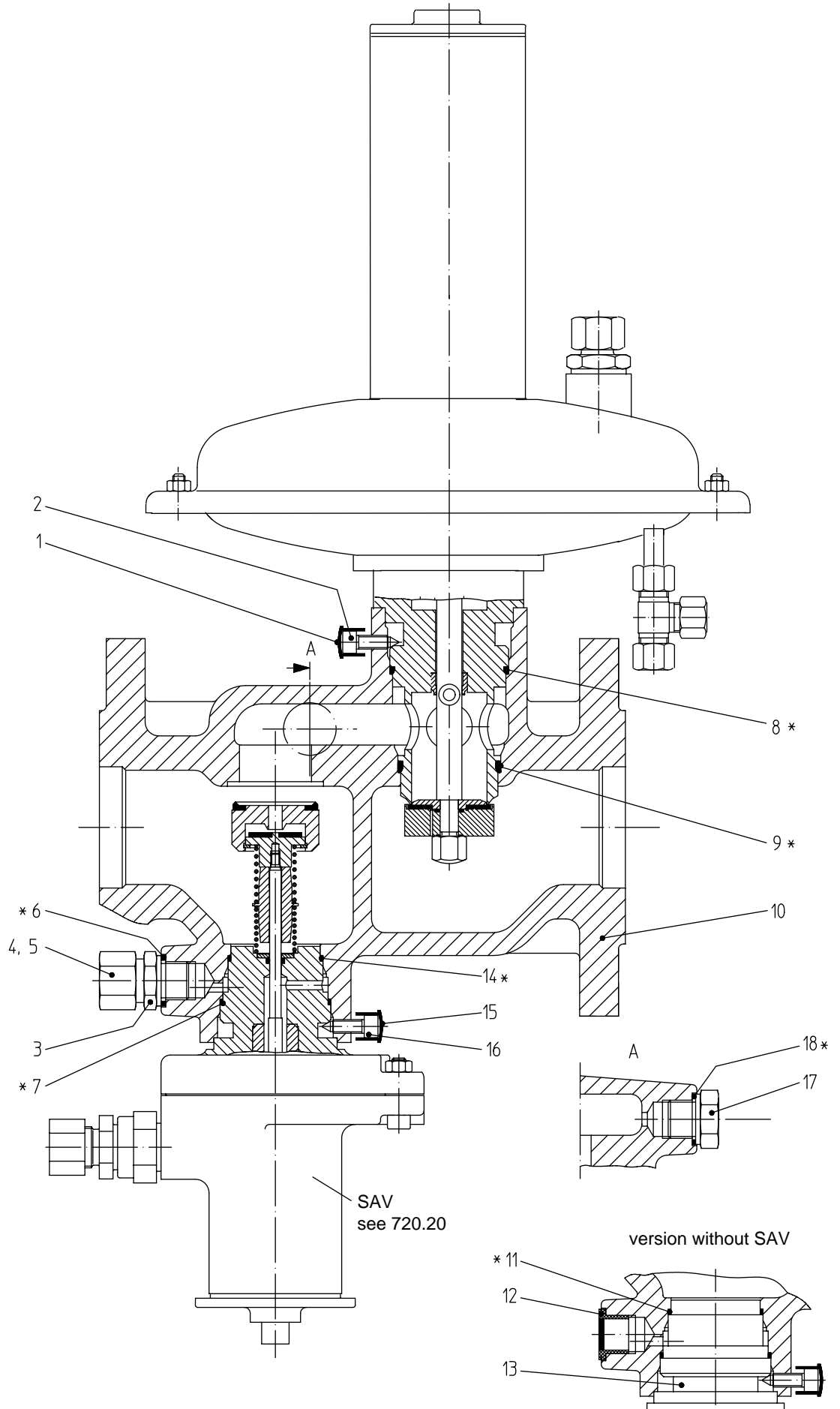

* Parts to be kept in stock for maintenance

Spare Parts List RMG 330 DN 25, DN 50
with Diaphragm Assembly size 1

item no.	description	material	stock no.	
			DN 25	DN 50
1	plug	K	00 026 066	00 026 066
2	cylinder screw	St	10 004 895	10 004 895
3	adapter	St	00 030 104	00 030 104
4	cap nut	St	00 030 804	00 030 804
5	compression joint	St	00 030 904	00 030 904
6*	sealing ring	LM	00 018 688	00 018 688
7*	o-ring	KG	00 020 293	00 020 293
8*	o-ring	KG	00 020 243	00 020 243
9*	o-ring	KG	00 020 241	00 020 241
10	valve body	GLM	10 004 852	10 004 850
11*	o-ring	KG	00 020 319	00 020 319
12	plug	K	00 026 067	00 026 067
13	closing plug	LM	10 004 909	10 004 909
14*	o-ring	KG	00 020 319	00 020 319
15	plug	K	00 026 066	00 026 066
16	cylinder screw	St	10 004 895	10 004 895
17	screw plug	St	00 010 363	00 010 363
18*	sealing ring	LM	00 018 688	00 018 688

* Parts to be kept in stock for maintenance.

Material-key:

St	... steel	K	... plastic material
LM	... light metal	KG	... rubber-like plastic material
GLM	... light metal cast		

Spare Parts Drawing RMG 330 DN 80, DN 100

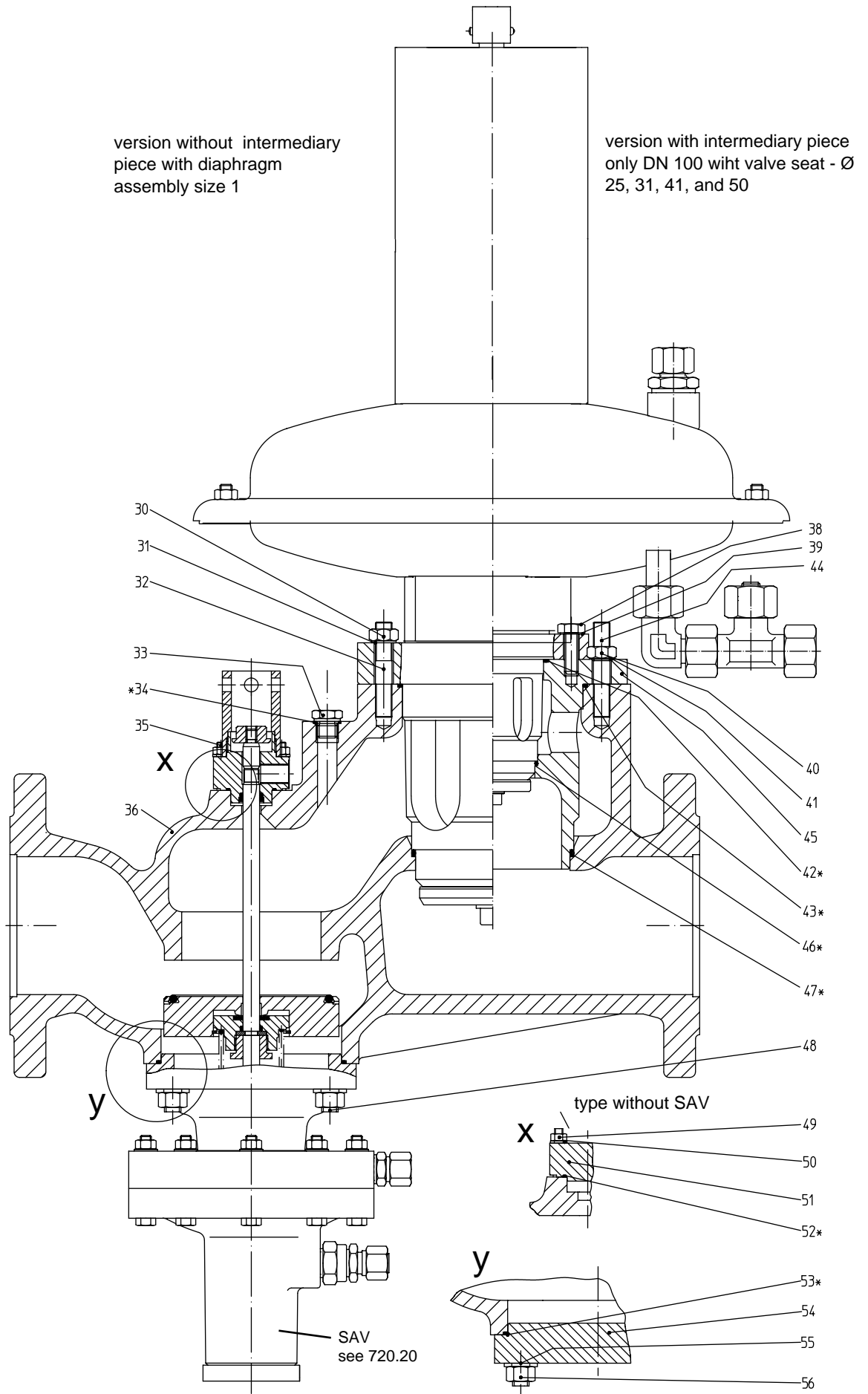

* Parts to be kept in stock for maintenance

Spare Parts List RMG 330 DN 80, DN 100

with Diaphragm Assembly size 1 or 2

item no.	description	material	stock no.	
			DN 80	DN 100
30	hexagon nut	St	00 005 692	00 013 120
31	safety washer	FSt	00 014 121	00 014 114
32	locking screw	St	00 012 397	00 012 350
33	screw plug	St	00 026 175	00 026 175
34*	sealing ring	LM	00 018 789	00 018 789
35	locking screw	St	00 012 324	00 012 324
36	valve body	GLM/St/NSt	10 009 031	10 009 104
38	hexagon screw	St	-	00 010 032
39	safety washer	FSt	-	00 014 121
40	hexagon nut	St	-	00 013 120
41	safety washer	St	-	00 014 114
42*	o-ring	KG	-	00 020 246
43*	o-ring	KG	00 020 246	00 020 427
44	locking screw	St	-	00 012 350
45	distance piece	LM	-	10 007 204
46*	o-ring	KG	-	00 020 425
47*	o-ring	KG	00 020 425	00 020 259
48	locking screw	St	00 012 067	00 012 067
49	hexagon nut	St	00 003 399	00 003 399
50	washer	St	00 008 279	00 008 279
51	upper locking plate	LM	10 007 693	10 007 693
52*	o-ring	KG	00 020 281	00 020 281
53*	o-ring	KG	00 020 427	00 020 427
54	lower locking plate	LM	10 007 675	10 007 675
55	safety washer	FSt	00 014 114	00 014 114
56	hexagon nut	St	00 013 120	00 013 120

* Parts to be kept in stock for maintenance.

Material-key:

St	... steel	FSt	... spring steel
LM	... light metal	KG	... rubber-like plastic material
NSt	... stainless steel	GLM	... light metal cast

Spare Parts Drawing 1

with valve seat - \varnothing 20, 33 mm

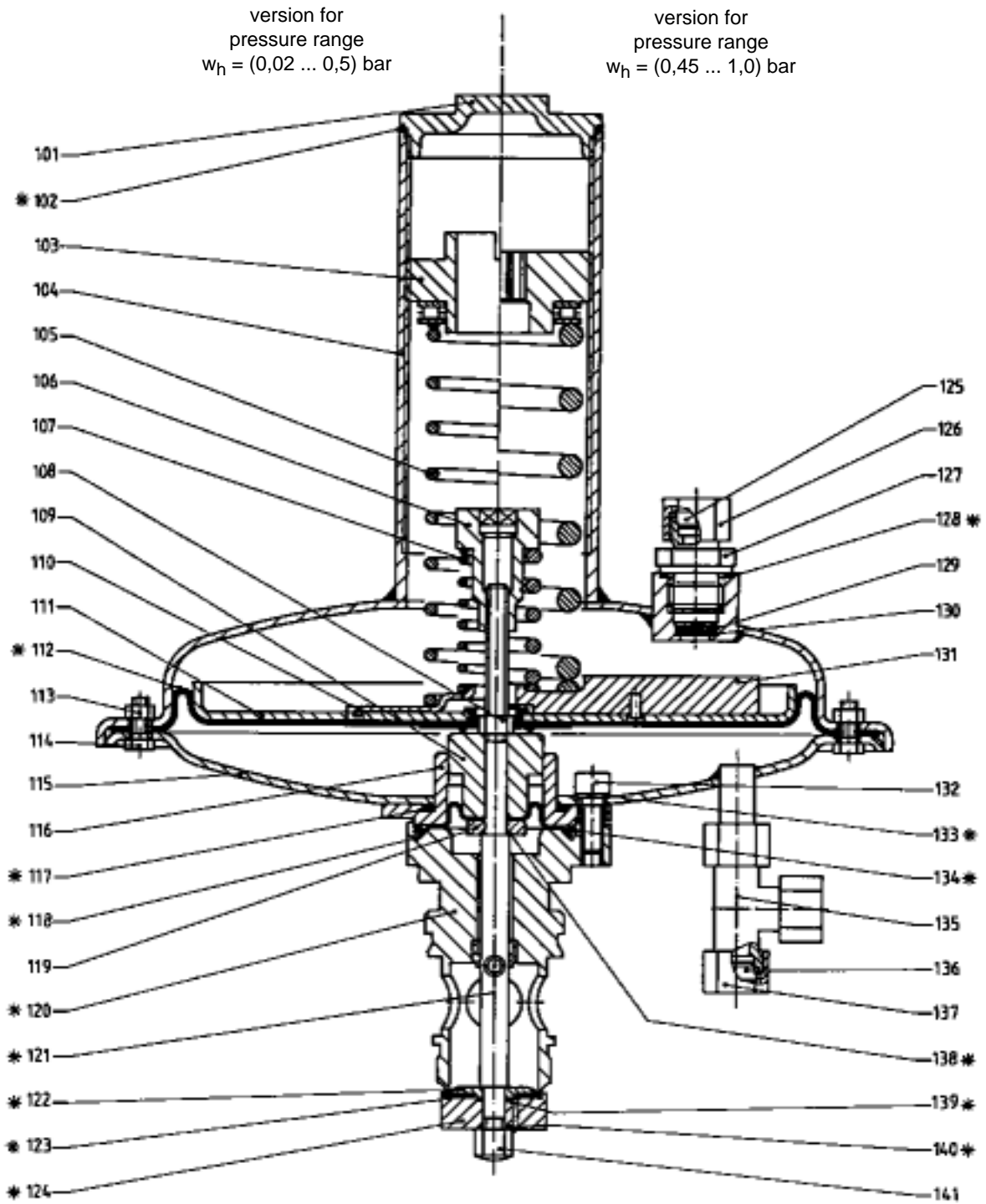

* Parts to be kept in stock for maintenance

Spare Parts List, Diaphragm Assembly size 1

with valve seat size Ø 20, 33 mm

item no.	description	material	stock no.	
			Ø 20	Ø 33
101	cap	GZn	10 003 641	10 003 641
102*	sealing ring	K	10 003 640	10 003 640
103	adjusting screw, complete at option:			
-	0,02 bar to 0,5 bar	GZn/St	10 003 637	10 003 637
-	0,45 bar to 1,0 bar	Ms/St	10 004 875	10 004 875
104	diaphragm cover, complete	St	10 003 604	10 003 604
105	pressure spring, complete:			
-	Wh 0,02 bar to 0,05 bar (grey)	FSt	10 003 629	10 003 629
-	Wh 0,045 bar to 0,1 bar (yellow)	FSt	10 003 630	10 003 630
-	Wh 0,09 bar to 0,2 bar (brown)	FSt	10 003 631	10 003 631
-	Wh 0,15 bar to 0,3 bar (light red)	FSt	10 003 632	10 003 632
-	Wh 0,25 bar to 0,4 bar (dark red)	FSt	10 003 633	10 003 633
-	Wh 0,35 bar to 0,5 bar (light blue)	FSt	10 003 634	10 003 634
-	Wh 0,45 bar to 0,6 bar (white) **	FSt	10 012 563	10 012 563
-	Wh 0,55 bar to 0,8 bar (green) **	FSt	10 012 564	10 012 564
-	Wh 0,65 bar to 1,0 bar (black) **	FSt	10 004 894	10 004 894
106	adjusting piece	LM	10 003 627	10 003 627
107	pressure spring for response pressure, at option:			
-	10 mbar to 100 mbar > pa (grey)	FSt	10 003 636	10 003 636
-	75 mbar to 300 mbar > pa (dark blue)	FSt	10 003 620	10 003 620
108	hexagon nut	St	00 005 559	00 005 559
109	guide piece	Ms	10 004 860	10 004 861
110	spring plate (version 0,02 bar to 0,5 bar)	St	10 003 626	10 003 626
111	diaphragm plate	LM	10 003 625	10 003 625
112*	diaphragm	KG	10 003 606	10 003 606
113	hexagon nut	St	00 003 399	00 003 399
114	hexagon screw	St	00 008 172	00 008 172
115	diaphragm housing	St	10 003 601	10 003 601
116	distance plate	LM	10 004 858	10 004 859
117*	o-ring	KG	00 020 306	00 020 306
118*	compensation diaphragm	KG	10 003 619	10 003 618
119	pressure disc	LM	10 003 609	10 003 608
120*	orifice, complete	LM/AIBz	10 004 862	10 004 863
121*	valve stem	NSt	10 004 878	10 004 878
122*	carrying piece	LM	10 003 603	10 003 602
123*	sealing washer	KG	-	10 003 552
124*	valve plate	LM, LM/KG	10 023 461	10 023 465
125	compression joint	St	00 030 904	00 030 904
126	cap nut	St	00 030 804	00 030 804
127	threaded adapter	St	00 030 142	00 030 142

* Parts to be kept in stock for maintenance.

** For these setpoint springs the support disc item no. 131 is additionally necessary.

Material-key:

St	... steel	Ms	... brass	GZn	... zinc cast
LM	... light metal	FSt	... spring steel	AIBz	... aluminium bronze
NSt	... stainless steel	KG	... rubber-like plastic material	K	... plastic material

Spare Parts List, Diaphragm Assembly size 1

with valve seat size Ø 20, 33 mm

item no.	description	material	stock no.	
			Ø 20	Ø 33
128*	sealing ring	LM	00 018 787	00 018 787
129	locking ring	FSt	00 019 135	00 019 135
130	slotted disc	KG	10 003 607	10 003 607
131	support disc, complete (version 0,45 bar to 1 bar)	LM/St	10 004 898	10 004 898
132	cylinder screw	St	00 010 323	00 010 323
133*	sealing ring	LM	00 018 710	00 018 710
134*	o-ring	KG	00 021 161	00 021 161
135	bleed valve E 12	St/Ms/KG	10 004 060	10 004 060
136	compression joint	St	00 030 904	00 030 904
137	cap nut	St	00 030 804	00 030 804
138*	sealing ring	LM	00 018 710	00 018 710
139*	o-ring	KG	-	00 020 595
140*	sealing ring	LM	00 018 710	00 018 710
141	cap nut	St	00 013 015	00 013 015

* Parts to be kept in stock for maintenance.

Material-key:

St ...steel

FSt ... spring steel

LM ... light metal

KG ... rubber-like plastic material

Ms ... brass

Spare Parts Drawing
Diaphragm Assembly size 1
 with valve seat - Ø 25, 31, 41, 50 mm

version for $w_h = (0,02 \dots 0,5 \text{ bar})$

version for $w_h = (0,45 \dots 1,0 \text{ bar})$

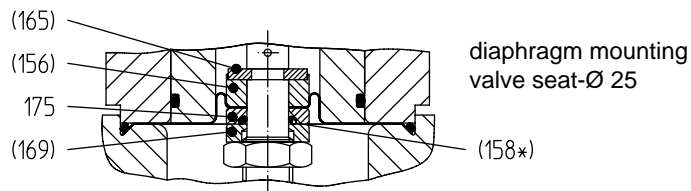
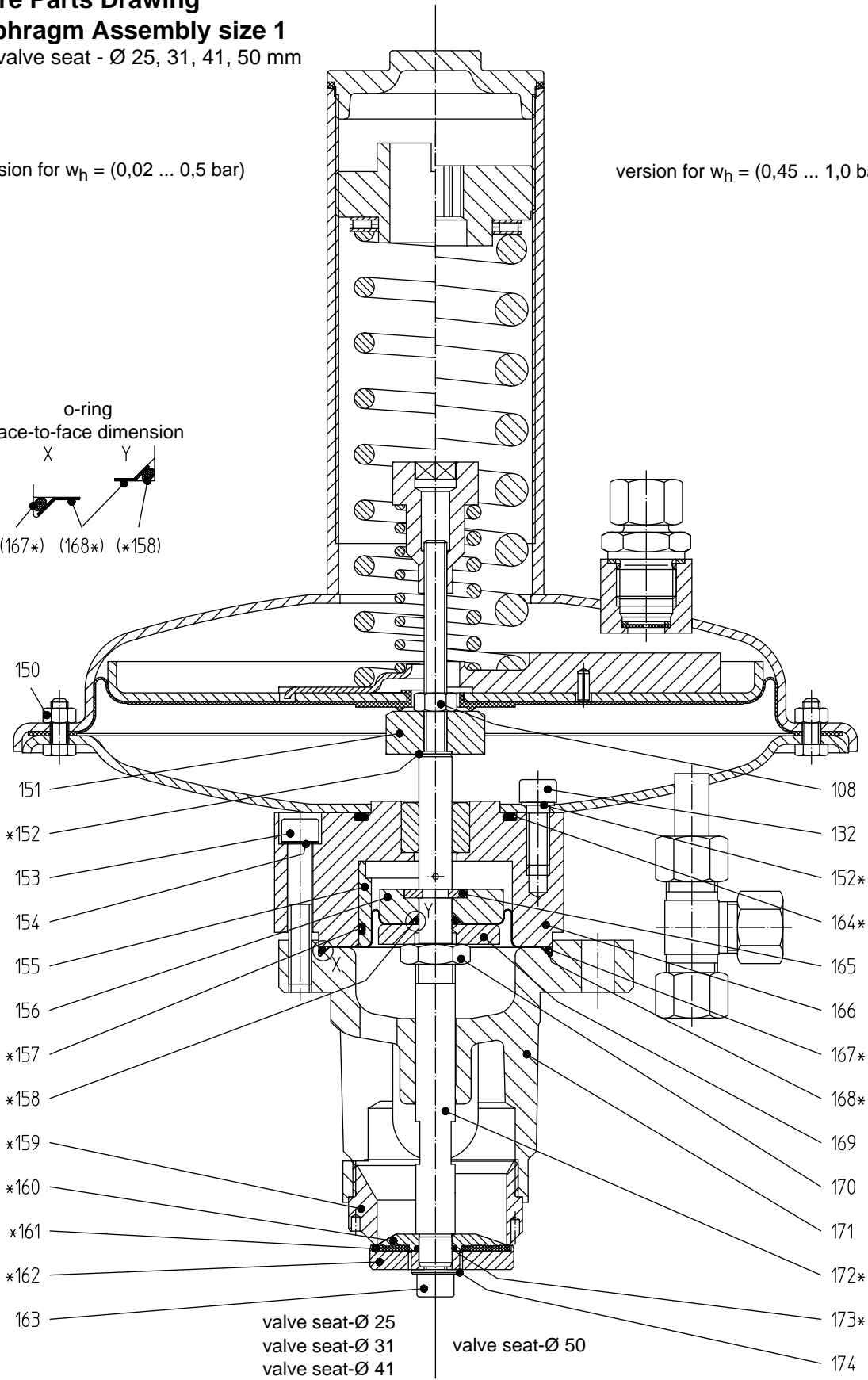
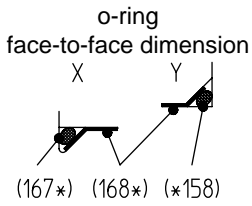

Spare Parts List, Diaphragm Assembly size 1

with valve seat size Ø 25, 31, 41, 50 mm

item no.	description	material	stock no.			
			Ø 25	Ø 31	Ø 41	Ø 50
108	hexagon nut	St	00 005 559	00 005 559	00 005 559	00 005 559
132	cylinder screw	St	00 010 323	00 010 323	00 010 323	00 010 323
151	check piece	LM	10 009 049	10 009 049	10 009 049	10 009 049
152*	sealing ring (5)	LM	00 018 710	00 018 710	00 018 710	00 018 710
153	cylinder screw	St	00 010 389	00 010 389	00 010 389	00 010 389
154	safety washer	FSt	00 014 122	00 014 122	00 014 122	00 014 122
155	reducing adapter	LM	10 006 188	10 009 082	10 009 083	-
156	diaphragm disc	LM	10 009 295	10 009 088	10 009 090	10 009 186
157*	o-ring	KG	00 020 243	00 020 243	00 020 243	-
158*	o-ring	KG	00 020 234	00 020 234	00 020 234	00 020 234
159*	orifice	LM	10 006 181	10 009 064	10 009 063	10 009 162
160*	carrying piece	LM	10 006 184	10 009 199	10 009 198	10 009 197
161*	valve sealing	KV1),KG	18 355 853	10 009 205	10 009 216	10 009 217
162*	valve plate	LM	10 023 463	10 023 464	10 009 201	10 009 200
163	cylinder screw	St	10 009 099	10 009 099	10 009 099	10 009 099
164*	o-ring	KG	00 020 325	00 020 325	00 020 325	00 020 325
165	ring segment (2)	St	10 008 612	10 008 612	10 008 612	10 008 612
166	adapting part, complete	LM/NSt	10 009 179	10 009 179	10 009 179	10 009 179
167*	o-ring	KG	00 020 246	00 020 246	00 020 246	00 020 246
168*	compensation diaphragm	KG	10 006 186	10 009 086	10 009 087	10 009 188
169	pressure disc	LM	10 009 297	10 009 089	10 009 091	10 009 187
170	hexagon nut	St	10 009 045	10 009 045	10 009 045	10 009 045
171	valve support	GG	10 009 161	10 009 161	10 009 161	10 009 161
172*	valve stem, complete	Ms/St	10 009 156	10 009 156	10 009 156	10 009 156
173*	o-ring	KG	00 020 451	00 020 451	00 020 451	00 020 451
174	washer	St	00 008 281	00 008 281	00 008 281	00 008 281
175	sealing ring	LM	10 009 296			

* Parts to be kept in stock for maintenance

Material-key:

St ... steel

Ms ... brass

GG ... grey cast iron

LM ... light metal

FSt ... spring steel

FPM ... synthetic rubber

NSt ... stainless steel

KG ... rubber-like plastic material

Spare Parts Drawing

Diaphragm Assembly size 1 with safety diaphragm

with valve seat - Ø 20, 33 mm Ø 25, 31, 41, 50 mm

$W_h = 0,02 \dots 0,5$ bar

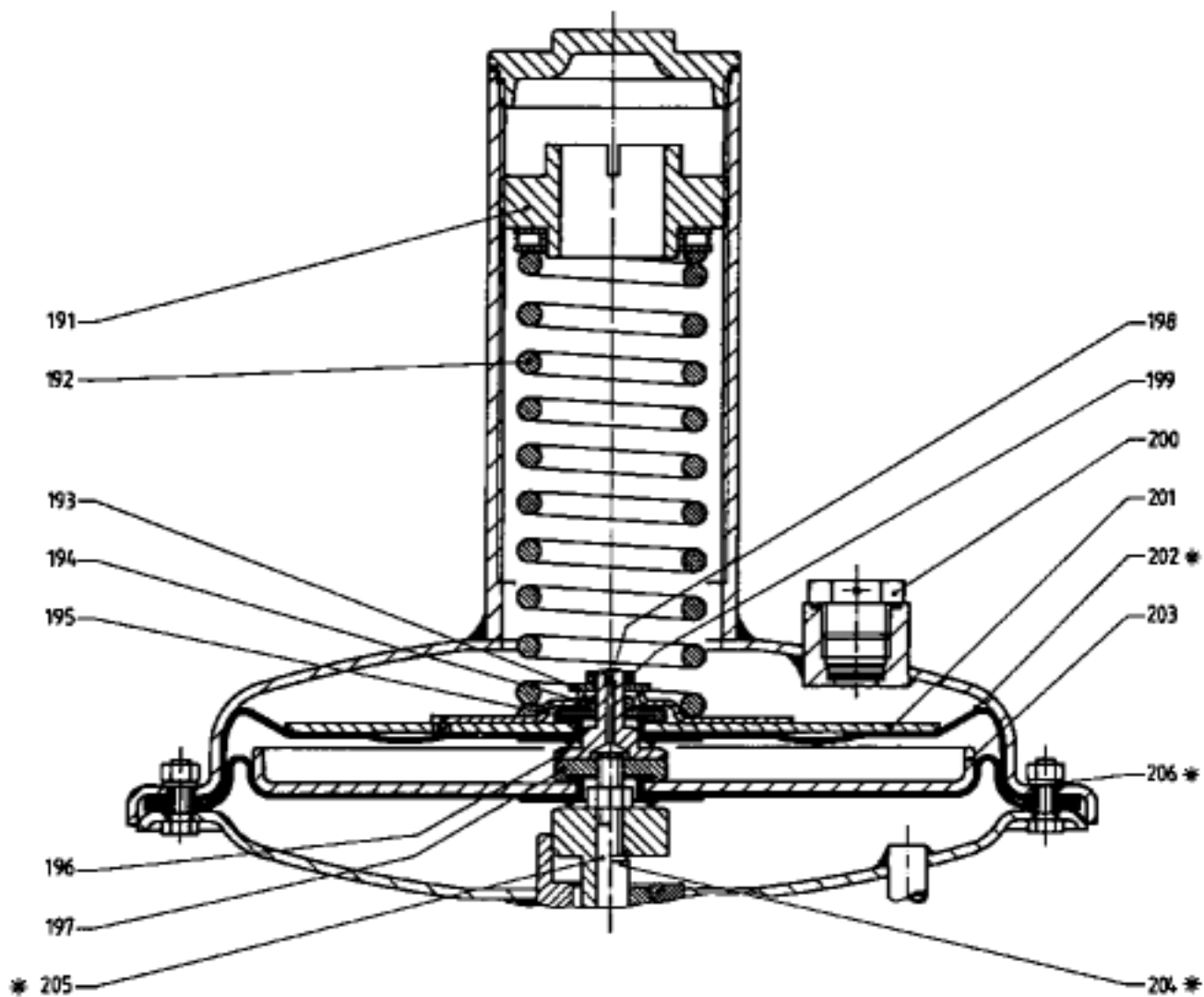

Parts without any pos. no., see on page 9

* Parts to be kept in stock for maintenance

Spare Parts List, Diaphragm Assembly size 1 with Safety Diaphragm

with valve seat size Ø 20, 33 mm or Ø 25, 31, 41, 50 mm

item no.	description	material	stock no.	
			Ø 20, 33	Ø 25, 31, 41, 50
191	adjusting screw, complete	GZn/St	10 003 637	10 003 637
192	pressure spring, at option:			
-	Wh 0,02 bar to 0,05 bar (grey)	FSt	10 003 629	10 003 629
-	Wh 0,045 bar to 0,1 bar (yellow)	FSt	10 003 630	10 003 630
-	Wh 0,09 bar to 0,2 bar (brown)	FSt	10 003 631	10 003 631
-	Wh 0,15 bar to 0,3 bar (light red)	FSt	10 003 632	10 003 632
-	Wh 0,25 bar to 0,4 bar (dark red)	FSt	10 003 633	10 003 633
-	Wh 0,35 bar to 0,5 bar (light blue)	FSt	10 003 634	10 003 634
193	washer	St	00 014 157	00 014 157
194	hexagon nut	St	00 013 115	00 013 115
195	adapting part	LM	10 006 178	10 006 178
196	locking screw	NSt	10 006 177	10 006 177
197	adapting part	St	10 006 189	10 006 189
198	threaded pin	St	00 012 405	00 012 405
199	hexagon nut	St	00 013 115	00 013 115
200	screw plug	K	00 027 178	00 027 178
201	diaphragm plate	LM	10 004 798	10 004 798
202*	safety diaphragm	KG	10 004 807	10 004 807
203	diaphragm plate	LM	10 004 809	10 004 809
204*	valve stem, complete	Ms/St	-	10 004 819
205*	valve stem	NSt	10 004 804	-
206*	threaded gasket (16)	St/K	00 021 162	00 021 162

* Parts to be kept in stock for maintenance.

Material-key:

St ... steel

Ms ... brass

GZn ... zinc cast

LM ... light metal

FSt ... spring steel

K ... plastic material

NSt ... stainless steel

KG ... rubber-like plastic material

Spare Parts Drawing
Diaphragm Assembly size 2
 with valve seat- Ø 25, 31, 41, 50 mm

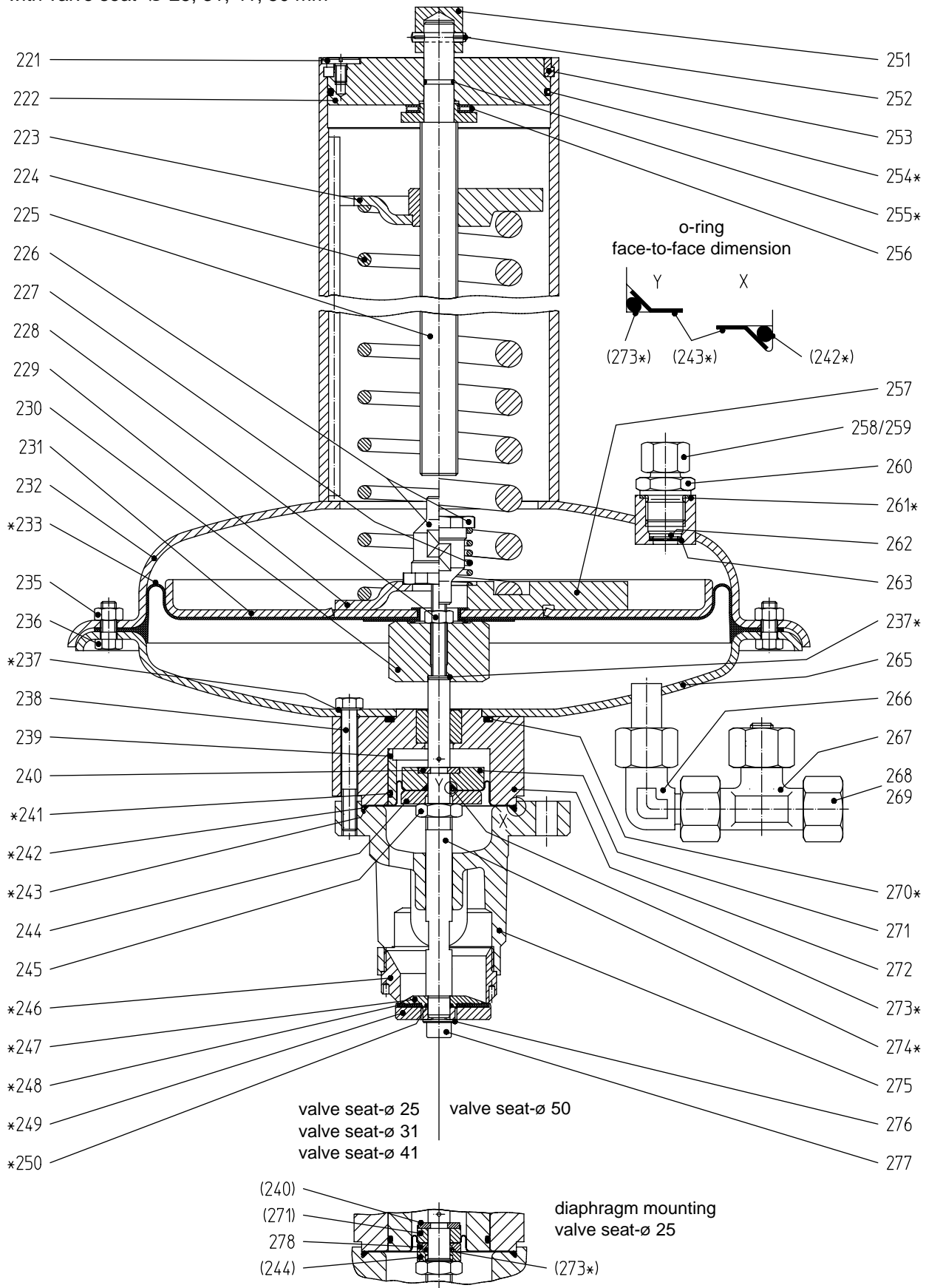

* Parts to be kept in stock for maintenance

Spare Parts List, Diaphragm Assembly Size 2

with valve seat size \varnothing 25, 31, 41, 50 mm

item no.	description	material	stock no.			
			\varnothing 25	\varnothing 31	\varnothing 41	\varnothing 50
221	screw	St	00 011 111	00 011 111	00 011 111	00 011 111
222	locking plate	LM	10 009 065	10 009 065	10 009 065	10 009 065
223	spring plate, at option:					
-	Wh 0,02 bar ... 0,5 bar	St,Ms	10 009 067	10 009 067	10 009 067	10 009 067
-	Wh 0,45 bar ... 1,0 bar	Ms	10 009 167	10 009 167	10 009 167	10 009 167
224	pressure spring, at option:					
-	Wh 0,02 bar ... 0,05 bar (grey)	FSt	10 009 068	10 009 068	10 009 068	10 009 068
-	Wh 0,045 bar ... 0,1 bar (yellow)	FSt	10 009 069	10 009 069	10 009 069	10 009 069
-	Wh 0,09 bar ... 0,2 bar (brown)	FSt	10 009 070	10 009 070	10 009 070	10 009 070
-	Wh 0,15 bar ... 0,3 bar (light red)	FSt	10 009 071	10 009 071	10 009 071	10 009 071
-	Wh 0,25 bar ... 0,4 bar (dark red)	FSt	10 009 072	10 009 072	10 009 072	10 009 072
-	Wh 0,35 bar ... 0,5 bar (light blue)	FSt	10 009 073	10 009 073	10 009 073	10 009 073
-	Wh 0,45 bar ... 0,6 bar (white)	FSt	10 009 163	10 009 163	10 009 163	10 009 163
-	Wh 0,55 bar ... 0,8 bar (green)	FSt	10 009 164	10 009 164	10 009 164	10 009 164
-	Wh 0,65 bar ... 1,0 bar (black)	FSt	10 009 165	10 009 165	10 009 165	10 009 165
225	adjusting spindle, complete	St	10 009 048	10 009 048	10 009 048	10 009 048
226	adjusting piece	LM	10 009 178	10 009 178	10 009 178	10 009 178
227	pressure spring or arresting tube, at option:					
-	for 15 mbar > pa (yellow) (version 0,02 bar ... 0,5 bar)	FSt	10 009 151	10 009 151	10 009 151	10 009 151
-	for 40 mbar > pa (red) (version 0,02 bar ... 0,5 bar)	FSt	10 009 152	10 009 152	10 009 152	10 009 152
-	for 130 mbar > pa (dark blue)	FSt	10 009 153	10 009 153	10 009 153	10 009 153
228	hexagon nut	St	00 013 140	00 013 140	00 013 140	00 013 140
229	spring plate (version: 0,02...0,5 bar)	St	10 009 102	10 009 102	10 009 102	10 009 102
230	check piece	LM	10 009 159	10 009 159	10 009 159	10 009 159
231	diaphragm plate	LM	10 009 168	10 009 168	10 009 168	10 009 168
232	diaphragm cover, complete	St	10 009 036	10 009 036	10 009 036	10 009 036
233*	diaphragm	KG	10 009 046	10 009 046	10 009 046	10 009 046
235	hexagon nut	St	00 013 140	00 013 140	00 013 140	00 013 140
236	hexagon screw	St	00 010 065	00 010 065	00 010 065	00 010 065
237*	sealing ring (5)	LM	00 018 710	00 018 710	00 018 710	00 018 710
238	hexagon screw	St	00 010 277	00 010 277	00 010 277	00 010 277
239	reducing adapter	LM	10 006 188	10 009 082	10 009 083	-
240	ring segment (2)	St	10 008 612	10 008 612	10 008 612	10 008 612
241*	o-ring	KG	00 020 243	00 020 243	00 020 243	-
242*	o-ring	KG	00 020 246	00 020 246	00 020 246	00 020 246
243*	compensation diaphragm	KG	10 006 186	10 009 086	10 009 087	10 009 188
244	pressure disc	LM	10 009 297	10 009 089	10 009 091	10 009 187

* Parts to be kept in stock for maintenance

** For these setpoint springs the support disc item no. 257 is additionally necessary.

Material-key: FSt ... spring steel
 St ... steel KG ... rubber-like plastic material
 LM ... light metal
 Ms ... brass

Spare Parts List, Diaphragm Assembly size 2
with valve seat size \varnothing 25, 31, 41, 50 mm

item no.	description	material	stock no.			
			\varnothing 25	\varnothing 31	\varnothing 41	\varnothing 50
245	hexagon nut	St	10 009 045	10 009 045	10 009 045	10 009 045
246*	orifice	LM	10 006 181	10 009 064	10 009 063	10 009 162
247*	carrying piece	LM	10 006 184	10 009 199	10 009 198	10 009 197
248*	valve sealing	KV1),KG	18 355 853	10 009 205	10 009 216	10 009 217
249*	valve plate	LM	10 023 463	10 023 464	10 023 450	10 023 451
250*	o-ring	KG	00 020 451	00 020 451	00 020 451	00 020 451
251	adjusting screw	St	10 009 055	10 009 055	10 009 055	10 009 055
252	cyl. dowel pin	St	00 017 145	00 017 145	00 017 145	00 017 145
253	half ring (2)	St	10 009 061	10 009 061	10 009 061	10 009 061
254*	o-ring	KG	00 020 248	00 020 248	00 020 248	00 020 248
255*	o-ring	KG	00 020 588	00 020 588	00 020 588	00 020 588
256	axial needle bearing	St	00 026 384	00 026 384	00 026 384	00 026 384
-	axial disc	St	00 026 385	00 026 385	00 026 385	00 026 385
257	support disc (version: 0,45 bar ... 1,0 bar)	LM	10 009 166	10 009 166	10 009 166	10 009 166
258	compression joint	St	00 030 904	00 030 904	00 030 904	00 030 904
259	cap nut	St	00 030 804	00 030 804	00 030 804	00 030 804
260	adapter	St	00 030 142	00 030 142	00 030 142	00 030 142
261*	sealing ring	LM	00 018 787	00 018 787	00 018 787	00 018 787
262	locking ring	FSt	00 019 135	00 019 135	00 019 135	00 019 135
263	slotted disc	KG	10 003 607	10 003 607	10 003 607	10 003 607
265	diaphragm housing, complete	St	10 009 037	10 009 037	10 009 037	10 009 037
266	adapter	St	00 031 203	00 031 203	00 031 203	00 031 203
267	bleed valve E 16	St/Ms/KG	10 008 996	10 008 996	10 008 996	10 008 996
268	compression joint	St	00 030 906	00 030 906	00 030 906	00 030 906
269	cap nut	St	00 030 807	00 030 807	00 030 807	00 030 807
270*	o-ring	KG	00 020 325	00 020 325	00 020 325	00 020 325
271	diaphragm disc	LM	10 009 295	10 009 088	10 009 090	10 009 186
272	adapting part, complete	LM/NSt	10 009 180	10 009 180	10 009 180	10 009 180
273*	o-ring	KG	00 020 234	00 020 234	00 020 234	00 020 234
274*	valve stem, complete	Ms/St	10 009 156	10 009 156	10 009 156	10 009 156
275	valve support	GG	10 009 161	10 009 161	10 009 161	10 009 161
276	washer	St	00 008 281	00 008 281	00 008 281	00 008 281
277	cylinder screw	St	10 009 099	10 009 099	10 009 099	10 009 099
278	sealing disc	LM	10 009 296			

* Parts to be kept in stock for maintenance.

material key:

St	... steel	FSt	... spring steel	GG	... grey cast iron
LM	... light metal	KG	... rubber-like plastic material	KV	... viton
Ms	... brass	NSt	... stainless steel		

Spare Parts Drawing
Diaphragm Assembly size 2
 with valve seat-Ø 60, 80, 100 mm

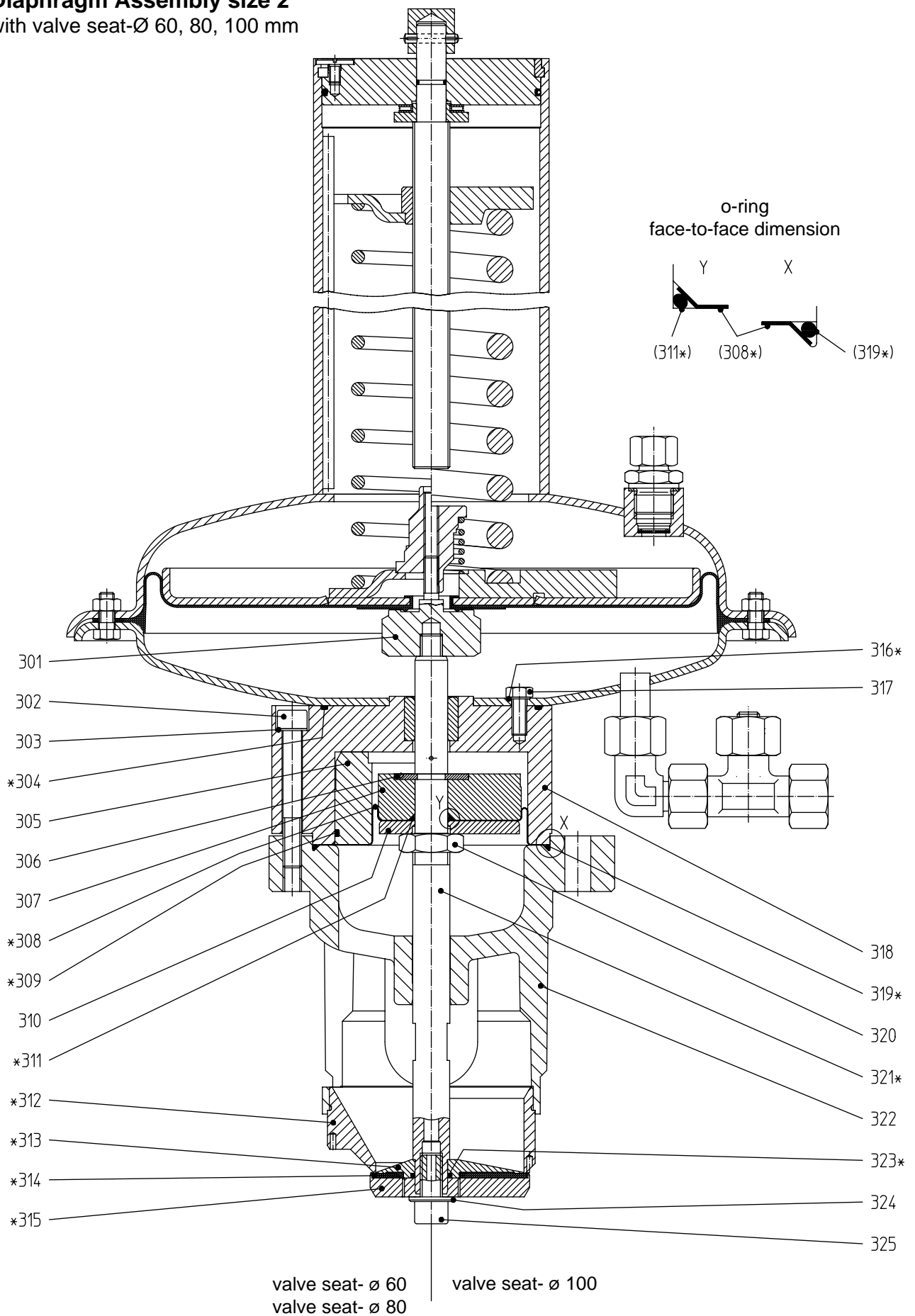

*Parts to be kept in stock for maintenance

Spare Parts List, Diaphragm Assembly Size 2

with valve seat size \varnothing 60, 80, 100 mm

item no.	description	material	stock no.		
			\varnothing 60	\varnothing 80	\varnothing 100
301	check piece	St	10 009 177	10 009 177	10 009 177
302	cylinder screw	St	00 010 386	00 010 386	00 010 386
303	safety washer	FSt	00 014 121	00 014 121	00 014 121
304*	o-ring	KG	00 020 355	00 020 355	00 020 335
305	reducing adapter	LM	10 009 114	10 009 115	-
306	ring segment (2)	St	10 009 129	10 009 129	10 009 129
307	diaphragm disc	LM	10 009 142	10 009 141	10 009 127
308*	compensation diaphragm	KG	10 009 120	10 009 134	10 009 137
309*	o-ring	KG	00 020 449	00 020 449	-
310	pressure disc	LM	10 009 124	10 009 125	10 009 128
311*	o-ring	KG	00 020 442	00 020 442	00 020 442
312*	orifice	LM	10 009 105	10 009 106	10 009 123
313*	carrying piece	LM	10 009 208	10 009 207	10 009 206
314*	valve sealing	KG	10 009 218	10 009 219	10 009 220
315*	valve plate	LM	10 023 452	10 023 453	10 023 454
316*	sealing ring	LM	00 018 710	00 018 710	00 018 710
317	hexagon screw	St	00 010 065	00 010 065	00 010 065
318	distance piece, complete	LM/NSt	10 009 139	10 009 139	10 009 139
319*	o-ring	KG	00 020 428	00 020 428	00 020 428
320	hexagon nut	St	10 009 109	10 009 109	10 009 109
321*	valve stem, complete	Ms/St	10 009 155	10 009 155	10 009 155
322	valve support	GG	10 009 133	10 009 133	10 009 133
323*	o-ring	KG	00 020 442	00 020 442	00 020 442
324	washer	St	00 008 271	00 008 271	00 008 271
325	cylinder screw	St	10 009 122	10 009 122	10 009 122

*Parts to be kept in stock for maintenance

Material-key:

St	... steel	GG	... grey cast iron	Ms	... brass
LM	... light metal	FSt	... spring steel		
NSt	... stainless steel	KG	... rubber-like plastic material		

We supply you with products for gas pressure regulation:



RMG REGEL + MESSTECHNIK GMBH

Osterholzstrasse 45, D-34123 Kassel, Germany
Telephone (++49) 561 5007-0 • Fax (++49) 561 5007-107

gas pressure regulators and safety devices



RMG-GASELAN Regel + Meßtechnik GmbH

Julius-Pintsch-Ring 3, D-15517 Fürstenwalde, Germany
Telephone (++49) 3361 356-60 • Fax (++49) 3361 356-836

gas pressure regulating equipment, displacement meters, complete stations



Bryan Donkin RMG Gas Controls Ltd.

Enterprise Drive, Holmewood, Chesterfield S42 5UZ, England
Telephone (++44) 1246 501-501 • Fax (++44) 1246 501-500

gas pressure regulating equipment, below ground gas control modules



Bryan Donkin RMG Co. of Canada Ltd.

50 Clarke Street South, Woodstock, Ontario N4S 7Y5, Canada
Telephone (++1) 519 5398531 • Fax (++1) 519 5373339

domestic regulators and safety devices

The other RMG Companies:



RMG Messtechnik GmbH

Otto-Hahn-Strasse 5, D-35510 Butzbach, Germany
Telephone (++49) 6033 897-0 • Fax (++49) 6033 897-130

turbine meters, vortex meters, correctors, flow computers, odorizers



Karl Wieser GmbH

Anzinger Strasse 14, D-85560 Ebersberg, Germany
Telephone (++49) 8092 2097-0 • Fax (++49) 8092 2097-10

Betriebsstelle Beindersheim

Heinrich-Lanz-Strasse 9, D-67259 Beindersheim/Pfalz, Germany
Telephone (++49) 6233 3762-0 • Fax (++49) 6233 3762-40

data logging, monitor systems, danger alarm systems



WÄGA Wärme-Gastechnik GmbH

Osterholzstrasse 45, D-34123 Kassel, Germany
Telephone (++49) 561 5007-0 • Fax (++49) 561 5007-207

design and assembly of gas pressure regulating and metering stations

The RMG Group of Companies on the internet: <http://www.rmg.de>

Serving the Gas Industry - WORLDWIDE



We reserve the right for technical changes