

Gas Pressure Regulator RMG 300 and RMG 300 "f"

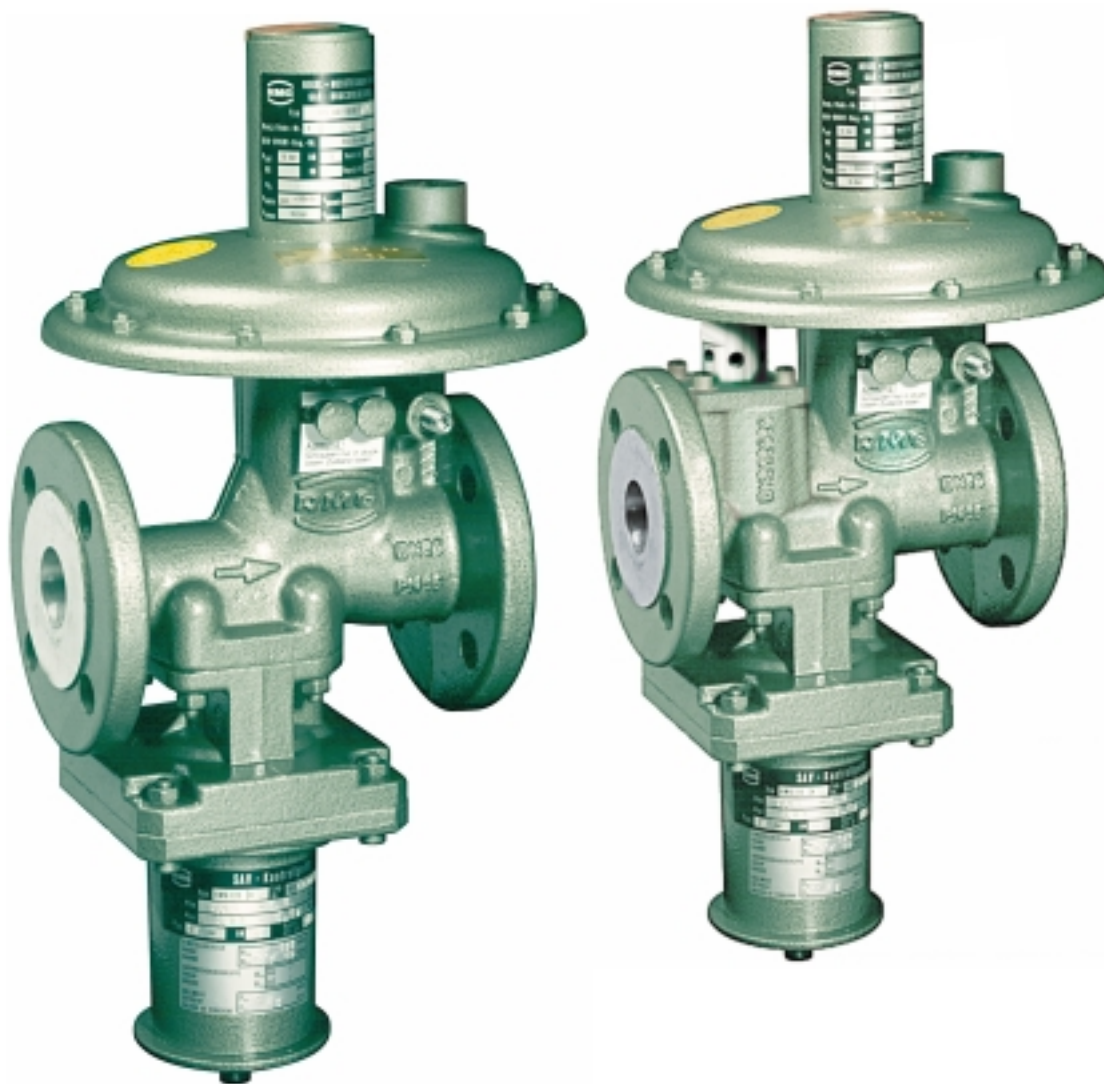

Technical Description

300.00

edition 06/2000

Safety and reliability in gas pressure regulation



Gas Pressure Regulator RMG 300 and RMG 300 "t"

Application

- device for systems acc. to DVGW worksheet G 600 (TRGI) or for RMG 300 "t" G 600 (TRGI) and G495/II
- suitable for systems requiring dynamic regulation (gas furnaces)
- suitable for natural gas and all non-aggressive gas media

Characteristics

- large inlet pressure range
- optional internal or external measuring connection
- actuator with pressure compensation
- easy maintenance due to exchangeable functional units
- control system with optional
 - integrated safety relief valve (SBV) for gas leakages
 - with vent valve RMG 915 (if SBV is blocked)
 - with safety diaphragm
- for RMG 300 "t" separate thermally actuated locking device (TAE)
 - with memory metal as temperature sensor and actuator
 - with metal seal at the the gas pressure regulator inlet

1. Specifications

max. inlet pressure p_{max}	16 bar (4 bar for RMG 300 "t")		
outlet pressure range in bar	measuring unit 1	measuring unit 2	spring no. / colour
	0.020 to 0.045		1 grey
	0.035 to 0.100		2 yellow
	0.080 to 0.200		3 ivory
	0.150 to 0.300		4 red
	0.250 to 0.400		5 green
	0.300 to 0.500	0.5 to 0.8	6 light blue
	0.400 to 0.800	0.6 to 2.0	7 dark blue
	SAV and SBV adjustment ranges see page 3		
accuracy class and closing pressure categories	accuracy class AC AC 2.5		closing pressure category SG 10
flow rate coefficient (for natural gas, $\rho_n = 0,83 \text{ kg/m}^3$)	valve seat diameter 11 mm		K_G value 65 m ³ /h
pipe size	DN 25		

Gas Pressure Regulator RMG 300 and RMG 300 "t"

connection type	DIN flange PN 16 Connection sizes according to DIN 2501			
material	main valve body actuator casing other pressure components internal components diaphragm, seals	<table border="1"> <tr> <td>RMG 300 Al alloy sheet steel St, Al alloy St, Al, Ms synth. rubber (NBR)</td> <td>RMG 300 "t" spheroidal graphite iron sheet steel St, Al alloy St, Al, Ms synth. rubber (NBR)</td> </tr> </table>	RMG 300 Al alloy sheet steel St, Al alloy St, Al, Ms synth. rubber (NBR)	RMG 300 "t" spheroidal graphite iron sheet steel St, Al alloy St, Al, Ms synth. rubber (NBR)
RMG 300 Al alloy sheet steel St, Al alloy St, Al, Ms synth. rubber (NBR)	RMG 300 "t" spheroidal graphite iron sheet steel St, Al alloy St, Al, Ms synth. rubber (NBR)			
TAE actuating temperature	appr. 100 C to 120 C			
function and strength	as per DVGW VP200 (DIN 33822)			
PED/CE and DIN DVGW	approved			

Setpoint ranges for control units K1a, K2a (safety shut-off unit type RMG 673)

control unit	setpoint spring			upper response pressure p_{so}		lower response pressure p_{su}		response pressure category**
	no.	colour	wire dia. in mm	setpoint range W_{ho} (bar)	re-engagement differential between response pressure and normal service pressure Δp_o (bar)	setpoint range W_{hu} (bar)	re-engagement differential between response pressure and normal service pressure Δp_u (bar)	
K1a	1	yellow	2.5	0.04...0.1	0.03			10/5
	2	light red	3.2	0.08...0.25	0.05			10/5
	3	dark red	3.6	0.2 ...0.5	0.10			5/2,5
	4	white	4.75	0.5 ...1.5	0.25			5/2,5
	5	yellow	1.0			0.01 ...0.015	0.012	15
	6	white	1.2			0.014...0.04	0.03	15/5
	7	black	1.4			0.035...0.12	0.06	5
K2a	2	light red	3.2	0.40...0.80	0.1			10/5
	3	dark red	3.6	0.60...1.60	0.2			10/5
	4	white	4.75	1.50...4.50	0.3			5/2,5
	5	light blue	1.1			0.06...0.15	0.05	15/5
	6	black	1.4			0.12...0.40	0.1	5

* Note: Where control devices are being used simultaneously for lower and upper actuating pressures, the difference between the two setpoint values p_{so} and p_{su} must be at least 10% greater than the sum of the re-engagement differentials Δp_o and Δp_u .

***) The higher AG group applies to the first half, the lower AG group to the second half of the setpoint range.



Gas Pressure Regulator RMG 300 and RMG 300 "t"

Setpoint range for leakage safety relief valve (SBV)

only for measuring unit 1 and $p_a \leq 500$ mbar:

With setpoint spring 1 - 7

SBV spring dia. 2.5 mm

10 mbar to 100 mbar above p_a

Connections of measuring and venting lines

measuring line* for pilot and SAV unit	R 1/4"; pipe 10 x 1.5 / E 10 (solderless pipe union with cutting ring according to DIN 2353)
venting line/relief line** for pilot	R 1/2", pipe 12 x 1.5 / E12 (solderless pipe union with cutting ring according to DIN 2353) or venting valve RMG 915 (not for dynamic regulating systems)
venting line for SAV units K1a/K2a	M 16 x 1,5; pipe 12 x 1.5 / E 12 (solderless pipe union with cutting ring according to DIN 2353) or venting valve RMG 915 or tripping valve RMG 919 with outside vent

*) not applicable for devices with internal measuring connection

***) not applicable for devices with safety diaphragm

Weight

RMG 300, RMG 300 "t"	SAV	
	without	with
	4 kg	5 kg

Gas Pressure Regulator RMG 300 and RMG 300 "t"

2. Dimensions

(Example: RMG 300 "t" with SAV control unit K1A/K2A)

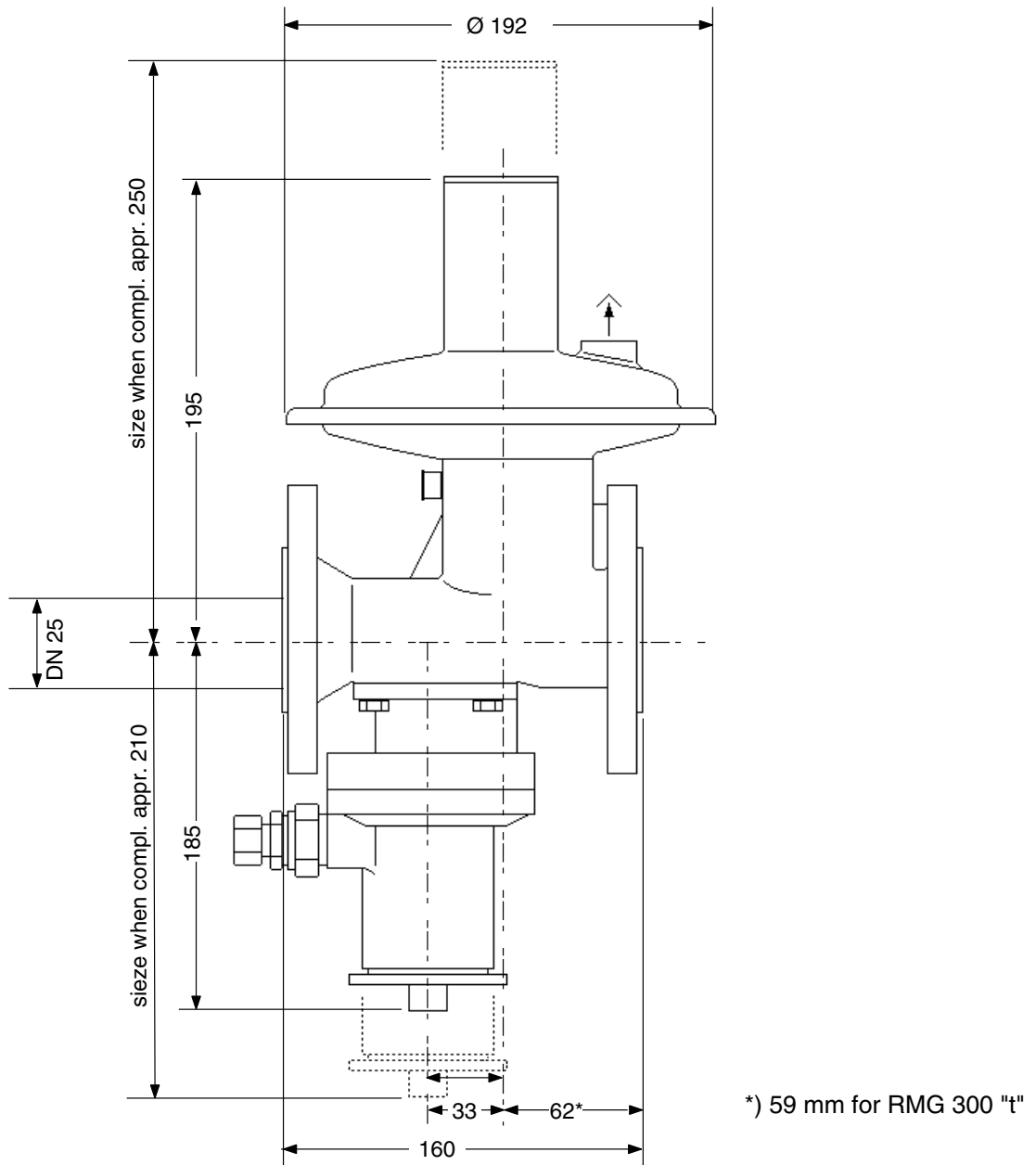

Gas Pressure Regulator RMG 300 and RMG 300 "t"

3. Design and operation

Example 1: RMG 300 "t" with internal measuring connection and gas leakage SBV in measuring unit 1, with safety stop valve (SAV) K1a, K2a and tripping valve RMG 919

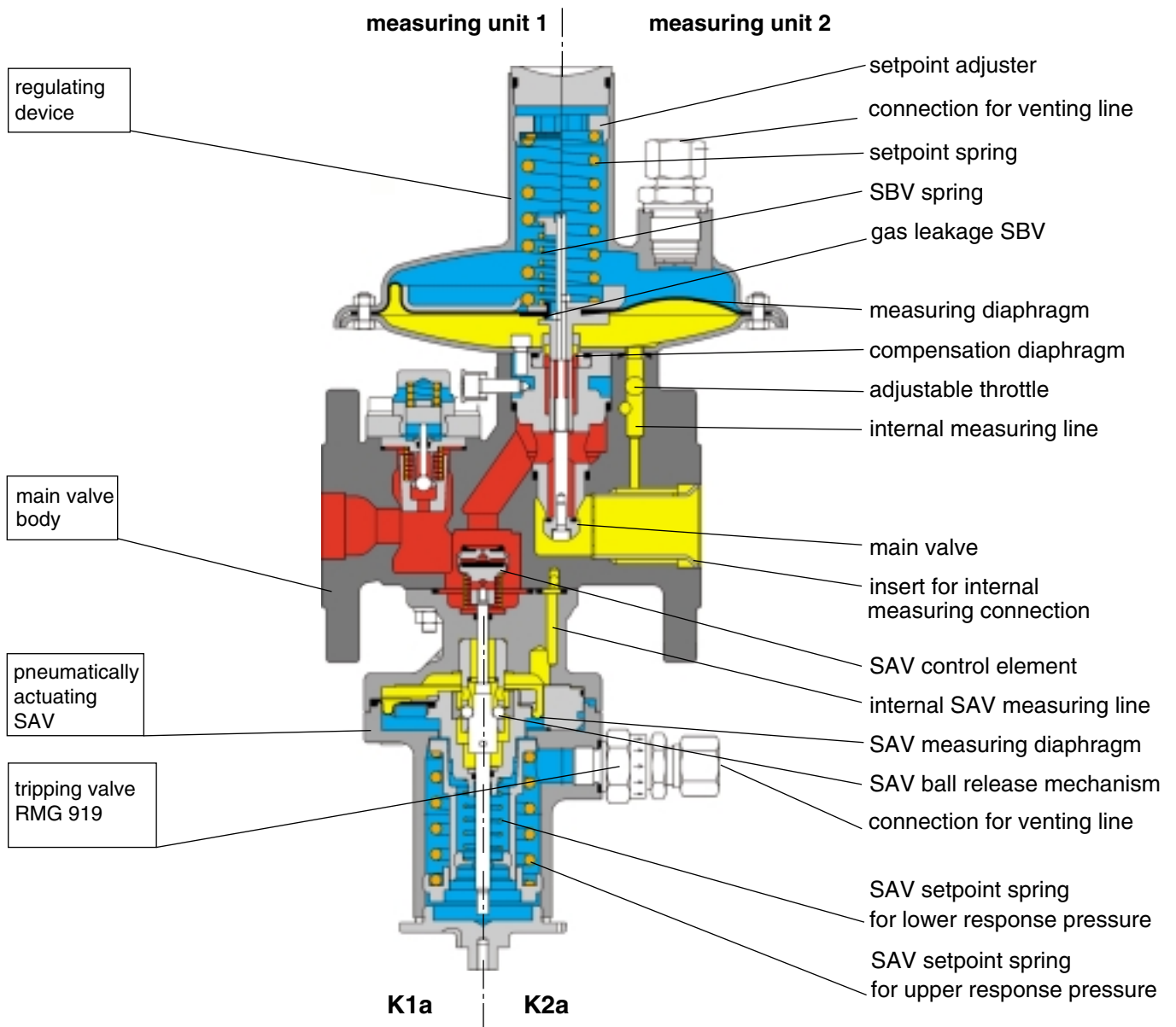

- inlet pressure
- outlet pressure
- atmosphere

Gas Pressure Regulator RMG 300 and RMG 300 "t"

Example 2: RMG 300 "t" with external measuring connection, with safety diaphragm in regulating device, with safety stop valve (SAV) K1A (K2A) and tripping valve RMG 919

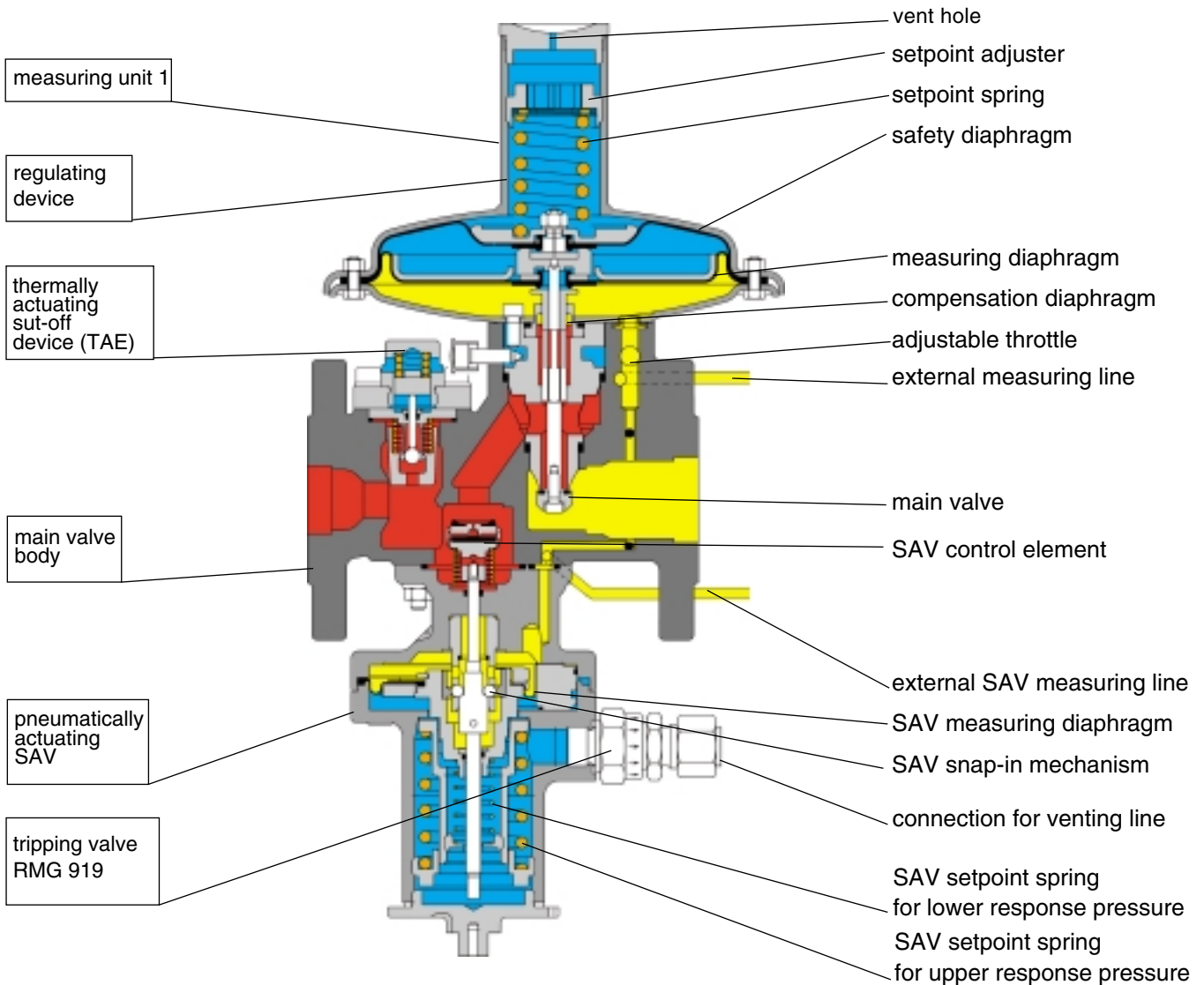

The gas pressure regulators RMG 300 and RMG 300 "t" are designed to keep the outlet pressure in the pipe system constant within given limits irrespective of gas delivery changes and changes of the inlet pressure. The gas regulator RMG 300 consists of the functional components "pilot" and "SAV unit"; the RMG 300 "t" has an additional thermally actuating shut-off device (TAE). The functional components can easily be removed from the main valve body after loosening the corresponding connection bolts.

This modular design allows to immediately renew the faulty functional unit with a tested replacement unit during an operational failure. The same applies during maintenance of the device. The regulating device consists of the main valve with valve plate and valve seat, the compensation diaphragm, and the measuring unit with measuring diaphragm, setpoint spring and setpoint adjuster. The safety shut-off device (SAV) consists of the SAV control element and the corresponding control units K1a or K2a.



Gas Pressure Regulator RMG 300 and RMG 300 "t"

The main valve body contains measuring bore holes which enable connecting an internal measuring connection for the pilot and SAV. When using external measuring lines the internal connections are sealed using balls pressed into the bore holes.

An adjustable throttle at the main valve body is used to tune the pilot to the pressure system. Optionally the safety relief valve for gas leakages (SBV) can be fitted to the regulating device. It is not required where a safety diaphragm has been fitted or is blocked when the venting valve RMG 915 is being added.

The output pressure to be regulated is directed from the measuring point to the underside of the measuring diaphragm. This senses the actual output pressure and compares it with the setpoint preset by the adjustable setpoint value (spring

tension). Any difference directly effects the main valve position via the valve rod. The resulting change in flow leads to an alignment of the actual output pressure to the setpoint value. At zero consumption the device seals off completely.

The SAV control unit monitors the output pressure at the measuring point (internal or external). When one of the preset release pressure values is reached, the SAV measuring diaphragm moves with the tripping device into the corresponding release position, the ball release mechanism releases the valve rod, and the SAV control element seals tight.

RMG 300 "t" thermally actuating shut-off device (TAE)



The TAE device is pre-tensioned by a spring.

Design

The thermally actuating shut-off device TAE is integrated into the inlet of the spheroidal graphite iron main valve body and consists of temperature sensor, closing mechanism, closing body, and the valve seat positioned in the main valve body. The closing body is normally locked in the open position. The ball switch is located between the two snap-in pins on the outer collars on which the closing body rests, tensioned by the closing spring. The push rod located above the ball switch is in contact with the temperature sensor designed as a spring made from so-called memory metal. The cover surrounding the memory metal spring features holes which allow the ambient temperature to affect the sensor directly.

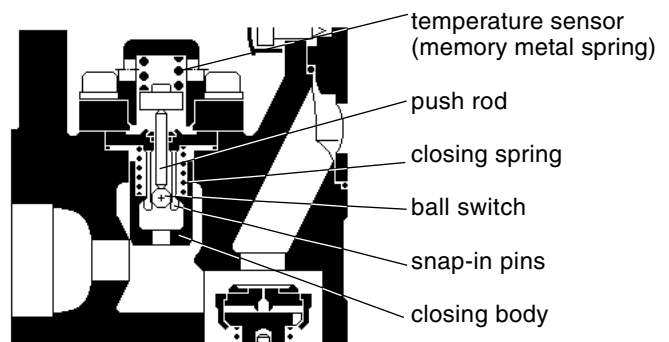

TAE open

Gas Pressure Regulator RMG 300 and RMG 300 "t"

Should the ambient temperature exceed the response temperature of the memory metal, the spring will extend longitudinally. Via the push rod the resulting high pressure forces the ball switch out of the snap-on pins. The conical closing body is set free and pressed by the pressure of the closing spring into the closing position between the valve seat and the abutment centred upon it. This design guarantees a safe closure. The closing body uses a material with a heat extension coefficient greater than that of the casing material. This produces increasingly greater closing forces with further rising temperature, aiding the safe closure.

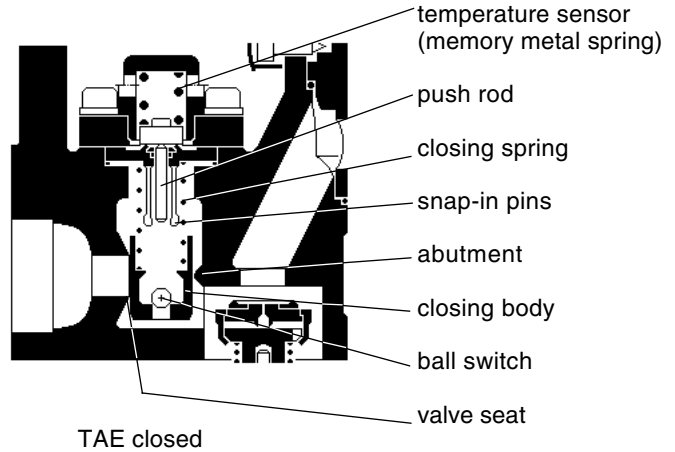

The diagram shows the typical leakage behaviour for the gas regulator RMG 300 "t" given the test conditions according to VP200 (DIN 33822).

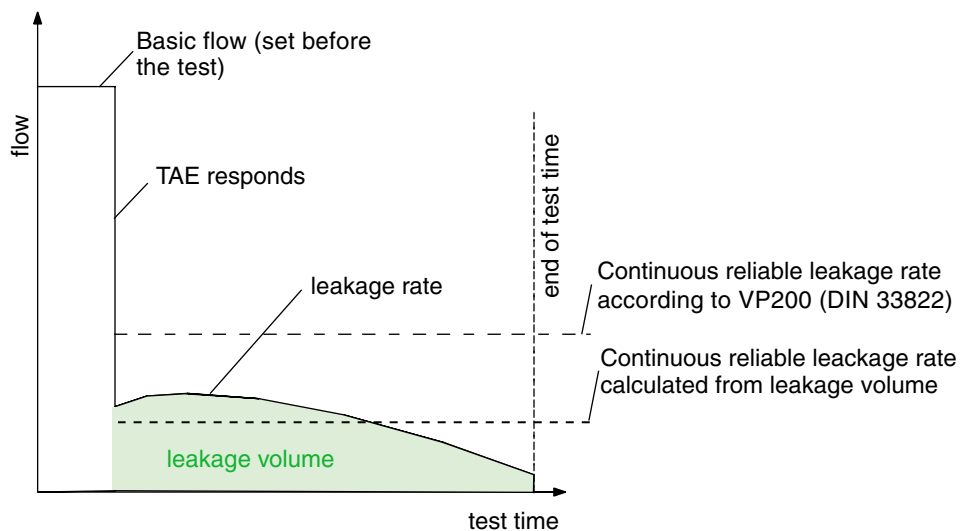

Gas Pressure Regulator RMG 300 and RMG 300 "t"

Device designation

The diagram below applies to gas pressure regulators RMG 300 and RMG 300 "t" with integral SAV unit. It indicates the nominal flow for natural gas as a function of inlet pressure p_e and outlet pressure p_a .

Nominal flow diagram for gas pressure regulator RMG 300 "t"

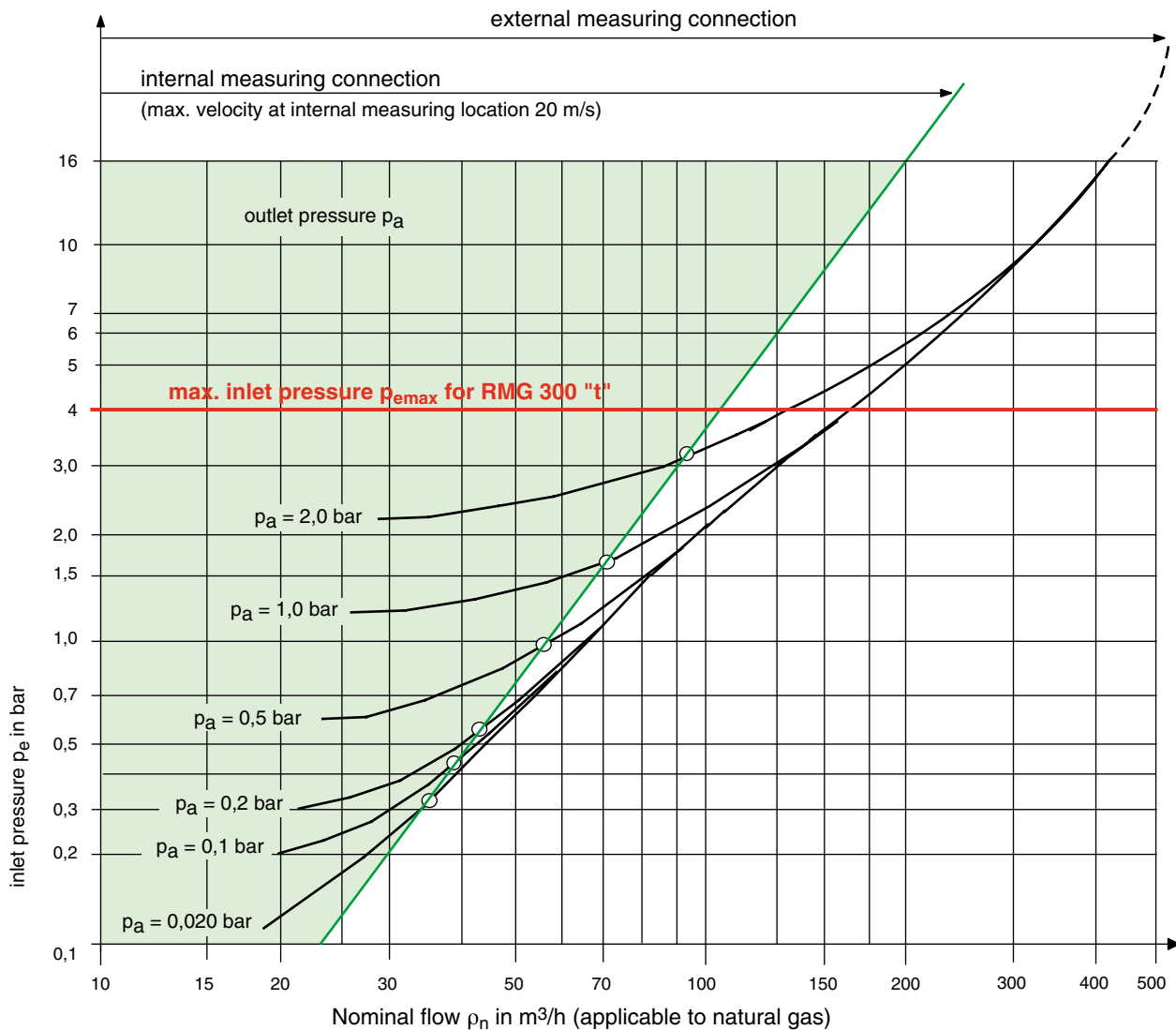

The maximum nominal flow values q_n can normally only be achieved where the outlet pipe is widened to a larger size. A maximum nominal flow of approx. 20 m/s also applies for this measuring point.

Gas Pressure Regulator RMG 300 and RMG 300 "t"

Regulator designation
(example)

RMG 300 "t" - 25 / 1 - K1a / 0 - 11 / 1L / 4 - So

Design		type edition	pipe size DN	code for measuring connection	SAV control unit	electrical remote indication of SAV valve setting	valve seat diameter of regulating device	design of pilot	setpoint spring no. in pilot	special features (to be detailed)
without TAE with TAE		- "t"								
Pipe size	measuring connection									
DN 25	internal external			1 2						
SAV control unit	Set range in bar W_{ho} W_{hu}									
K 1a K 2a	0.040 to 1.500 0.010 to 0.120 0.400 to 4.500 0.060 to 0.400			K 1a K 2a						
Remote indication										
without for K 1a or K 2a						0 T				
Valve seat diameter 11 mm							11			
Pilot with										
Actuator 1 with gas leak SBV Actuator 1 with blocked gas leak SBV Actuator 1 with safety diaphragm Actuator 2									1L 1 1S 2	
Setpoint spring no.	colour	Set range W_h in bar for actuator 1			for actuator 2					
1	grey	0.020 to 0.045								1
2	yellow	0.035 to 0.100								2
3	ivory	0.080 to 0.200								3
4	red	0.150 to 0.300								4
5	green	0.250 to 0.400								5
6	light blue	0.300 to 0.500			0.5 to 0.8					6
7	dark blue	0.400 to 0.800			0.6 to 2.0					7



We supply you with products for gas pressure regulation:



RMG REGEL + MESSTECHNIK GMBH

Osterholzstrasse 45, 34123 Kassel, Germany
Telephone (++49) 561 5007-0 • Fax (++49) 561 5007 107
gas pressure regulators and safety devices



RMG-GASELAN Regel + Meßtechnik GmbH

Julius-Pintsch-Ring 3, 15517 Fürstenwalde, Germany
Telephone (++49) 3361 356-60 • Fax (++49) 3361 356-836
gas pressure regulating equipment, displacement meters, complete stations



Bryan Donkin RMG Gas Controls Ltd.

Enterprise Drive, Holmewood, Chesterfield S42 5UZ, England
Telephone (++44) 1246 501-501 • Fax (++44) 1246 501-500
gas pressure regulating equipment, underground compact units



Bryan Donkin RMG Canada Ltd.

50 Clarke Street South, Woodstock, Ontario N4S 7Y5, Canada
Telephone (++1) 519 5398531 • Fax (++1) 519 5373339
domestic regulators and safety devices

The other RMG Companies



RMG Messtechnik GmbH

Otto-Hahn-Strasse 5, 35510 Butzbach, Germany
Telephone (++49) 6033 897-0 • Fax (++49) 6033 897-130
turbine meters, vortex meters, correctors, flow computers, odorizers



Karl Wieser GmbH

Anzinger Strasse 14, 85560 Ebersberg, Germany
Telephone (++49) 8092 2097-0 • Fax (++49) 8092 2097-10

works Beindersheim

Heinrich-Lanz-Strasse 9, 67259 Beindersheim/Pfalz, Germany
Telephone (++49) 6233 3762-0 • Fax (++49) 6233 3762-40
data logging, monitor systems, danger alarm systems



WÄGA Wärme-Gastechnik GmbH

Osterholzstrasse 45, 34123 Kassel, Germany
Telephone (++49) 561 5007-0 • Fax (++49) 561 5007-207
design and assembly of gas pressure regulating and metering stations

Die RMG Group of Companies on the internet: <http://www.rmg.de>

Your competent partner

serving the gas industry - WORLDWIDE

