

Pressure Reducing Valve RMG 218 (D118aV)

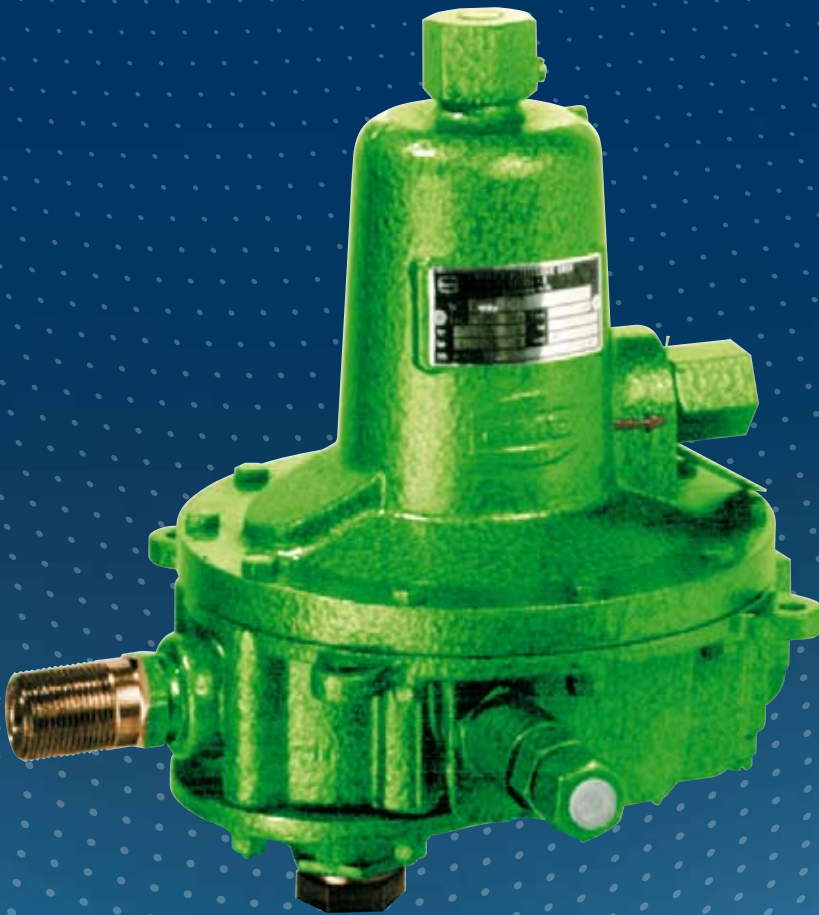

PRODUCT INFORMATION

**Serving the Gas Industry
Worldwide**

RMG
by Honeywell

Pressure Reducing Valve RMG 218 (D118aV)

Application

- for industrial and process applications
- suitable for natural gas and all non-corrosive gaseous media

Characteristics

- two-stage proportional regulating device
- suitable for large pressure drops
- inlet pressure variations lead only to very small outlet pressure deviations
- tight shut-off at zero flow (only for valves with plastic sealings)
- with safety relief valve (SBV) in the 1st control stage (10 bar)
- easy operation and maintenance
- not tested by DVGW

Technical data

max. inlet pressure p_{max}	350 bar
outlet pressure range W_h	0.006 bis 3.5 bar
intermediate pressure	max. 8 bar
operating temperature	-15°C to 60°C
material	body parts: aluminium internal parts: brass, steel valve sealing: NBR o-rings: NBR
connections - inlet	G3/4a (to p_{max} 50 bar) connection for gas bottle valve acc. to DIN 477 (to p_{max} 200 bar) screw connection without brazing acc. to DIN 2353 for external pipe diameters 10 mm, 12 mm, 16 mm
- outlet	G 1 1/4 i, for external pipe diameter 35 mm
weight	approximately 4.5 kg

Pressure Reducing Valve RMG 218 (D118aV)

Dimensions (in mm)

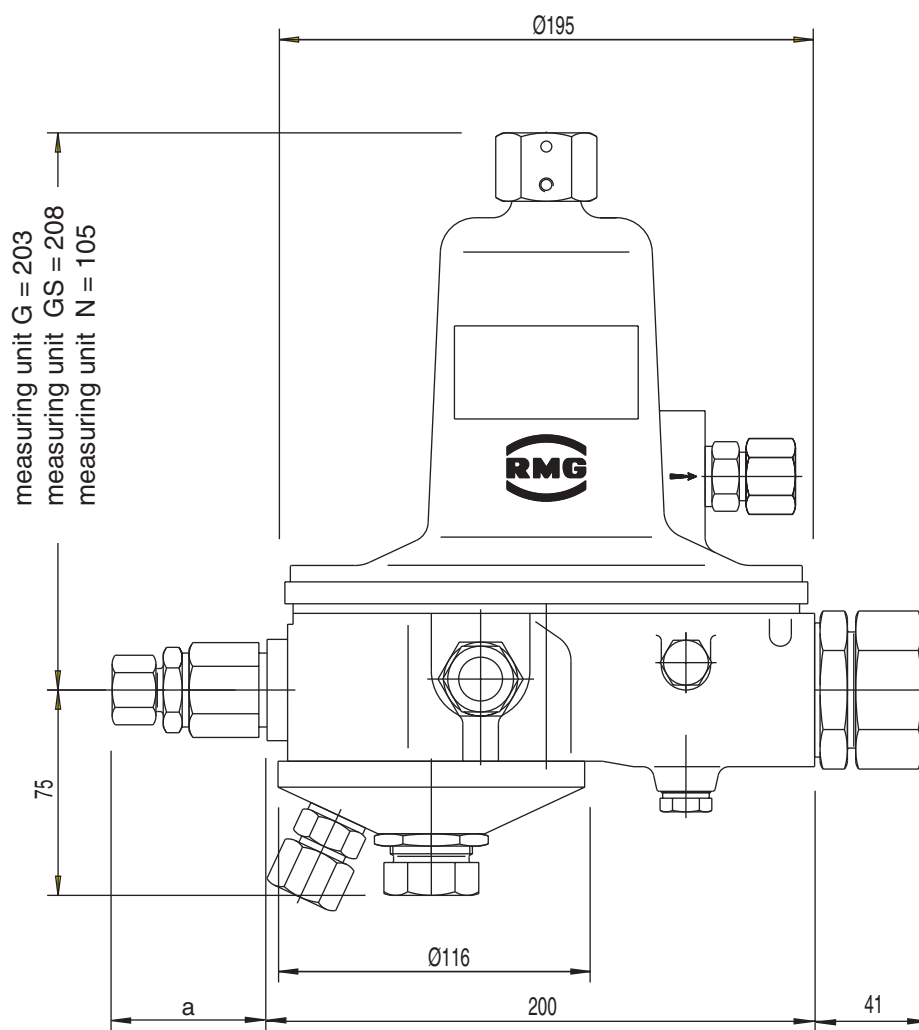

Sizes in mm

inlet	a
G 3/4a	50
E10	52
E12	54
E16	72
DIN 477	appr. 56



Pressure Reducing Valve RMG 218 (D118aV)

Design and operation

The pressure reducing valve works as a pilot with two pressure reduction stages, and is suitable for large pressure drops. The valve reduces the varying inlet pressure Δp_e to an adjustable outlet pressure p_a . The setpoint (outlet pressure or intermediate pressure) is supplied by a spring-loaded diaphragm. The pressure reducing valve can be fitted with three different measuring units and various regulating valves. It has a tight shut-off at zero flow, when using plastic valve sealings. Design and operation of the two stages are identical. The 1st control stage adjusts the inlet pressure p_e to an adjustable intermediate pressure, and the 2nd control stage adjusts to the set outlet pressure p_a . To avoid an unpermissible pressure increase the 1st control stage is always designed with an overpressure valve. The 2nd control stage is also designed with an overpressure valve only up to an outlet pressure p_a 0.5 bar. A gas filter should be mounted upstream to prevent the pressure reducing valve from impurities.

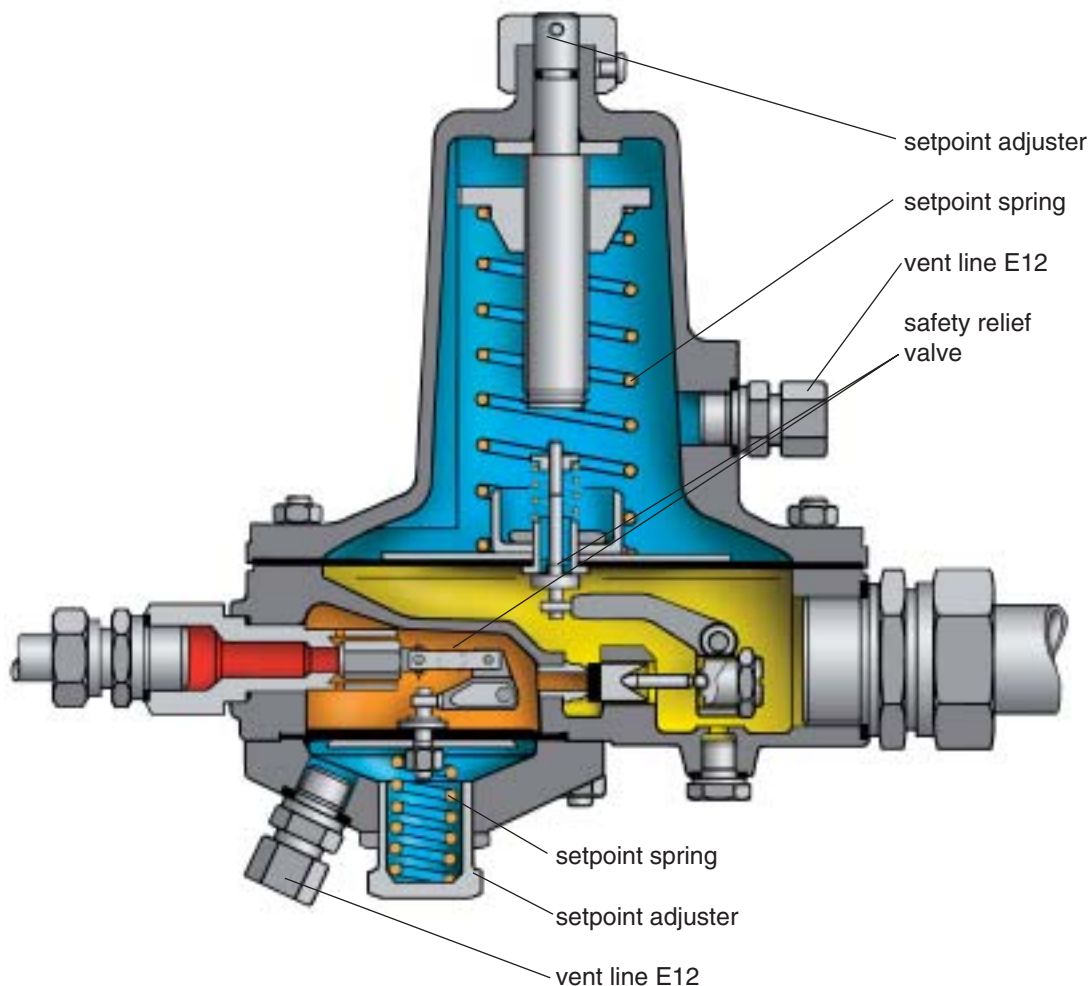

Pressure Reducing Valve RMG 218 (D118aV)

Valve data

1st control stage	valve dia. in mm	2	3.7	5.5	8	10**	
	K_G in m ³ /h*	4.5	15	35	65	90	
2nd control stage	valve dia. in mm	1.5	3.5	4,8	6	7	10
	K_G in m ³ /h*	2.5	14	25	38	50	90

valve flowrate coefficient for natural gas ($\rho_n = 0,83 \text{ kg/m}^3$)

** up to $p_e = 25 \text{ bar}$

Outlet pressure range of the measuring unit (2nd stage)

measuring unit	outlet pressure range W_h in bar	setpoint spring	wire- \emptyset (in mm)	SBV setting range ($> p_a$) in bar
N	0.020 ... 0.040	F 1	2.5	0.010 ... 0.025
	0.020 ... 0.060	F 2	3.0	0.010 ... 0.040
	fixed 0.008	F 11	1.2	0.010
	fixed 0.050	F 12	2.0	0.040
G	0.008 ... 0.012	F 1	2.5	0.010 ... 0.040
	0.010 ... 0.040	F 2	3.2	
	0.030 ... 0.100	F 3	4.0	0.040 ... 0.090
	0.075 ... 0.250	F 4	4.5	0.040 ... 0.090*) 0.100 ... 0.150**)
	0.150 ... 0.500	F 5	5.6	0.040 ... 0.090*) 0.090 ... 0.150**)
	0.25 ... 1.0	F 6	6.5	without SBV
	0.50 ... 1.8	F 7	8.0	
0.75 ... 2.0	F 8	9.0		
GS	0.60 ... 2.5	F 7	8.0	without SBV
	1.00 ... 3.5	F 8	9.0	

*) only up to orifice- \emptyset 7 mm **) only up to orifice- \emptyset 10 mm

Applicable pressure valves 1st control stage (depending on connection and inlet pressure)

description	pressure valves with						
	metal sealing		plastic valve sealing				
	approved up to inlet pressure (in bar)						
inlet and outlet	350	200	50	50	50	50	25
G 3/4 a / G 1 1/4 i	-	-	F2	F3.7	F5.5	F8	F10
DIN 477 / G 1 1/4 i	HH2*	H3.7	F2	F3.7	F5.5	-	-
pipe dia. 10/ G 1 1/4 i	HH2	H3.7	F2	F3.7	F5.5	-	-
pipe dia. 12/ G 1 1/4 i	HH2	H3.7	F2	F3.7	F5.5	F8	-
pipe dia. 16/ G 1 1/4 i	HH2	H3.7	F2	F3.7	F5.5	F8	F10

*) connections according to DIN 477: Valve HH2 only up to 200 bar



Pressure Reducing Valve RMG 218 (D118aV)

The table values are valid for q_{\max} for complete opening of the orifice. At a loading range of e. g. 50 % of q_{\max} the load dependency only amounts to 50 % of the values mentioned in the table.

Setpoint deviation due to flowrate dependency (for the measurable units in mbar)

orifice	N				G								GS	
	F1	F2	F11	F12	F1	F2	F3	F4	F5	F6	F7	F8	F7	F8
1.5	2	11.5	0.2	0.9	0.7	1.6	5	10	22	38	74	120	91	147
3.5	5	28.7	0.5	2.5	1.7	3.9	13	25	56	95	184	300	228	368
4.8	7	39.4	0.7	3.5	2.3	5.3	18	34	77	129	252	413	312	505
6	8	49.2	0.9	4.4	2.9	6.6	22	43	96	162	315	516	390	630
7	10	57.5	1	5.1	3.4	7.7	26	50	113	189	367	593	455	735
10	14	82	1.5	7.2	4.8	11	37	71	160	270	525	860	650	1050

Pressure Reducing Valve RMG 218 (D118aV)

Type description **D118aV - E10 / E35 - F5,5 / F7 - M/G - F3 - So**

(example)

connections											
inlet		G 3/4a E10 E12 E16 DIN 477									
outlet				G 1 1/4i E 35							
valve seat diameter and sealing type, 1st control stage				HH2 H3.7 F2 F3.7 F5.5 F8 F10							
valve seat diameter, 2nd control stage						1.5 3.5 4.8 6 7 10					
measuring unit								M/N M/G M/GS			
setpoint spring											
measuring unit	adjusting range W_h in bar								spring		
N	0.020 ... 0.040								F 1		
	0.020 ... 0.060								F 2		
	fixed 0.008								F 11		
	fixed 0.050								F 12		
G	0.008 ... 0.012								F 1		
	0.010 ... 0.040								F 2		
	0.030 ... 0.100								F 3		
	0.075 ... 0.250								F 4		
	0.150 ... 0.500								F 5		
	0.25 ... 1.0								F 6		
GS	0.50 ... 1.8								F 7		
	0.75 ... 2.0								F 8		
	0.60 ... 2.5								F 7		
1.00 ... 3.5								F 8			
special version (is to be specified in detail)										So	



For More Information

To learn more about RMG's advanced gas solutions, contact your RMG account manager or visit www.honeywell.com/ps/rmg

GERMANY

Honeywell Process Solutions

RMG Regel + Messtechnik GmbH
Osterholzstrasse 45
34123 Kassel, Germany
Tel: +49 (0)561 5007-0
Fax: +49 (0)561 5007-107

Honeywell Process Solutions

RMG Messtechnik GmbH
Otto-Hahn-Strasse 5
35510 Butzbach, Germany
Tel: +49 (0)6033 897-0
Fax: +49 (0)6033 897-130

Honeywell Process Solutions

RMG Gaselan Regel + Messtechnik GmbH
Julius-Pintsch-Ring 3
15517 Fürstenwalde, Germany
Tel: +49 (0)3361 356-60
Fax: +49 (0)3361 356-836

Honeywell Process Solutions

WÄGA Wärme-Gastechnik GmbH
Osterholzstrasse 45
34123 Kassel, Germany
Tel: +49 (0)561 5007-0
Fax: +49 (0)561 5007-207

POLAND

Honeywell Process Solutions

Gazomet Sp. z o.o.
ul. Sarnowska 2
63-900 Rawicz, Poland
Tel: +48 (0)65 5462401
Fax: +48 (0)65 5462408

ENGLAND

Honeywell Process Solutions

Bryan Donkin RMG Gas Controls Ltd.
Enterprise Drive, Holmewood
Chesterfield S42 5UZ, England
Tel: +44 (0)1246 501-501
Fax: +44 (0)1246 501-500

CANADA

Honeywell Process Solutions

Bryan Donkin RMG Canada Ltd.
50 Clarke Street South, Woodstock
Ontario N4S 7Y5, Canada
Tel: +1 (0)519 5398531
Fax: +1 (0)519 5373339

USA

Honeywell Process Solutions

Mercury Instruments LLC
3940 Virginia Avenue
Cincinnati, Ohio 45227, USA
Tel: +1 (0)513 272-1111
Fax: +1 (0)513 272-0211