

Gas Pressure Regulator RMG 214 (D 144a)



**Operation and Maintenance,
Spare Parts**

214.20
edition 07/2003

Serving the Gas Industry - WORLDWIDE



1. General

The "Technical Description 214.00" for the gas pressure regulator of series RMG 214 contains technical data, versions and dimensions.

Our brochure "General Operating Instructions for Gas Pressure Regulators and Safety Devices" will be useful to fit the valve into the line, put into the line, put into service and find faults that might disturb the operation.

The construction, set-up, supervision and maintenance of gas pressure pressure stations are subject to various national technical rules, which should be strictly observed. In Germany please refer to the DVGW-Worksheets G 490, G 491 and G 495.

Note: The vent line of the integrated safety relief valve is to be connected to the open atmosphere (outside of the building).

The frequency of periodical maintenance of gas pressure regulator RMG 214 should be determined according to the prevailing conditions and the type and composition of the gaseous medium. We, therefore, abstain from imposing any fixed intervals. In Germany please refer to the recommendations given by the DVGW-Worksheets G 495.

For maintenance all parts are to be cleaned and subjected to a thorough visual inspection. A visual inspection should not be omitted when the course of operation or functional tests have shown lack of regulating accuracy.

Particular care should be given to the checking of sealings and diaphragms, as well as carrying and moving parts. Damaged parts should be replaced by new ones.

The item numbers referred to in the maintenance instructions are identical with those of spare parts drawings and spare parts lists. We recommend to keep all parts that are marked "W" in the spare parts lists in stock for prompt maintenance availability..

2. Special Operating Instructions

valve seat diameter

Take care that not more than the permissible inlet pressure prevails on the inlet side of the RMG 214 as to avoid damage to internal parts

valve seat diameter 6 mm	$p_{e \max} = 350 \text{ bar}$
valve seat diameter 8 mm	$p_{e \max} = 220 \text{ bar}$
valve seat diameter 11 mm	$p_{e \max} = 150 \text{ bar}$

regulating deviations

Admissible regulating deviations depend on constructive details and can be caused by:

- inlet pressure variations (see table in Technical Description 214.00 or in the RMG booklet)
- flow variations (accuracy depending on the individual setpoint spring, see table in Technical Description 214.00 or in the RMG booklet)
- flow resistance in the outlet channels (increases with higher flowrate)

bubble-tight shut-off

As the regulators have valve sealing made of plastic material, the close bubble-tight at zero consumption.

3. Maintenance Hints

3.1 piston (7)

The piston (7) responsible for tight shut-off can be exchanged after removing the screw cap (21).

3.2 internal parts (valve seat (8), guide piece (10), diaphragm (11), setpoint spring (14), etc.)

The internal parts can be reached from under the body by unscrewing the spring housing (15) or the intermediate piece (52).

The internal parts should move easily and must be faultless. Take care that the measuring diaphragm is not beginning to dissolve or fall apart due to aggressive gas components.

NOTE: When mounting the spring housing take care not to tighten the lid too strongly. Only apply enough force to press the diaphragm down for not more than 1 mm. This is sufficient to achieve tightness.

4. Spare Parts RMG 214
 4.1 Spare Parts Drawing
 4.1.1 Version with internal measuring impulse connection

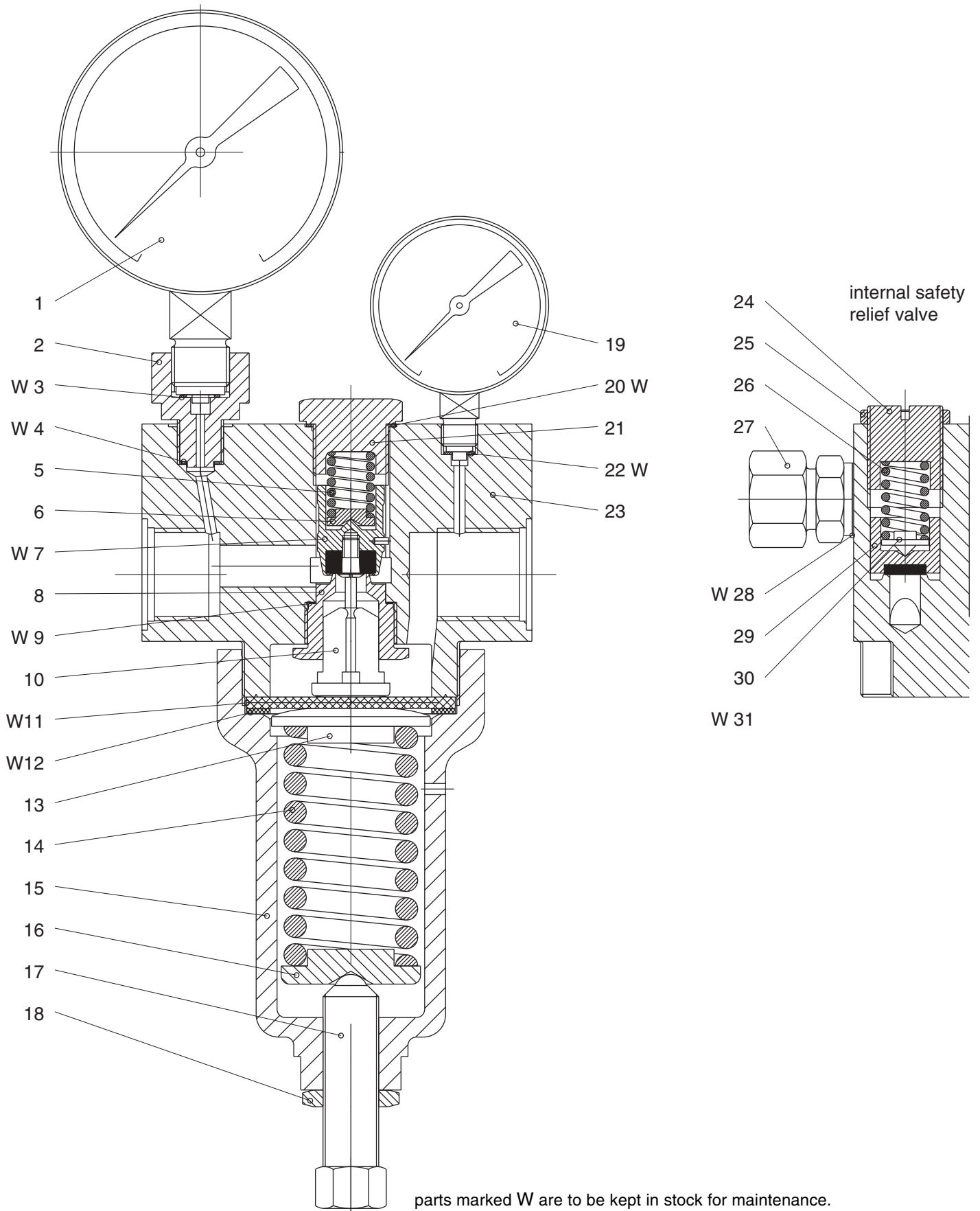

4. spare parts RMG 214
 4.1 spare parts drawing
 4.1.2 version with external measuring line

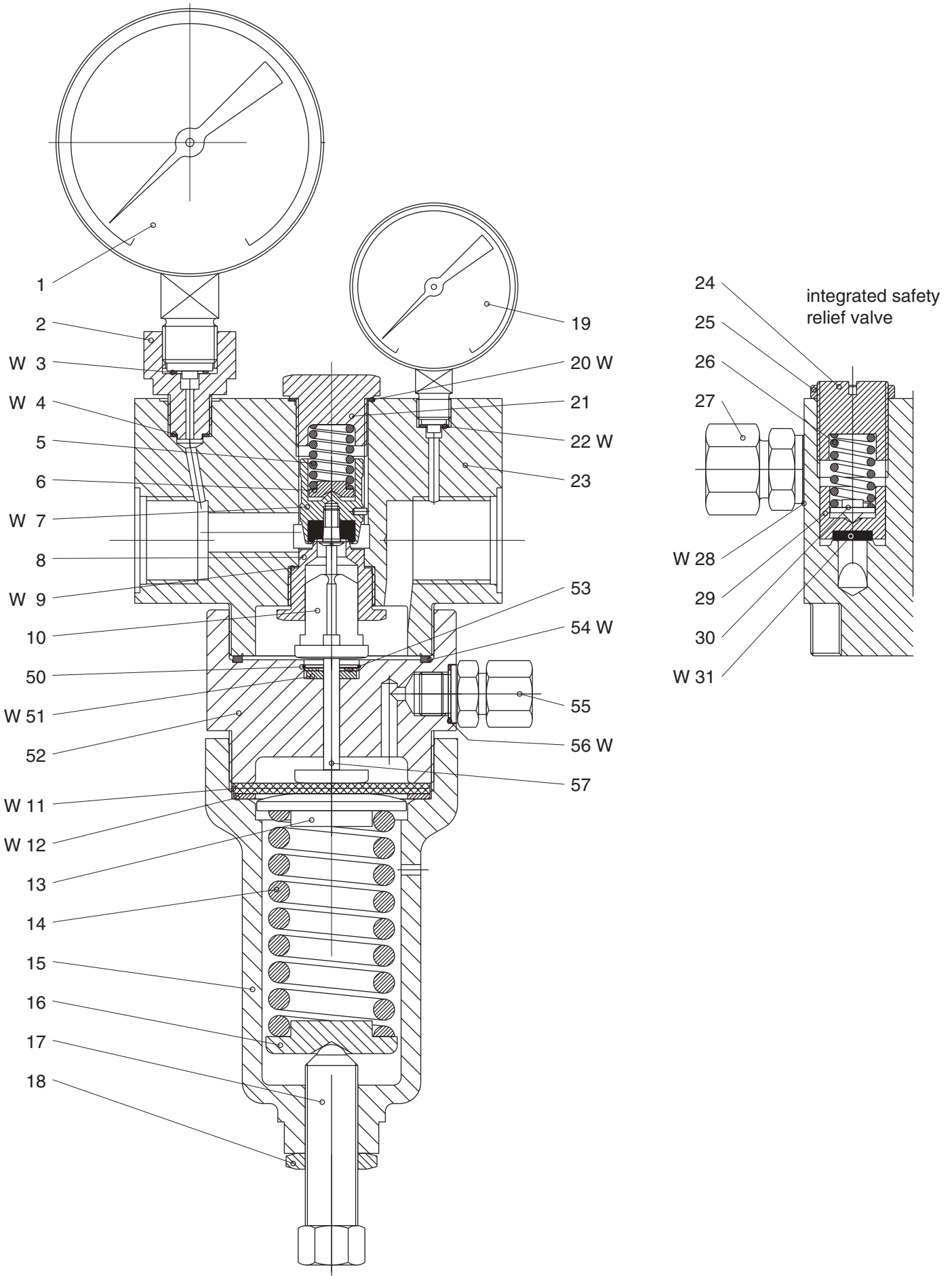

- 4. spare parts RMG 214
- 4.1 spare parts drawing
- 4.1.3 back-flow proof version, only for valve seat dia. 6 mm

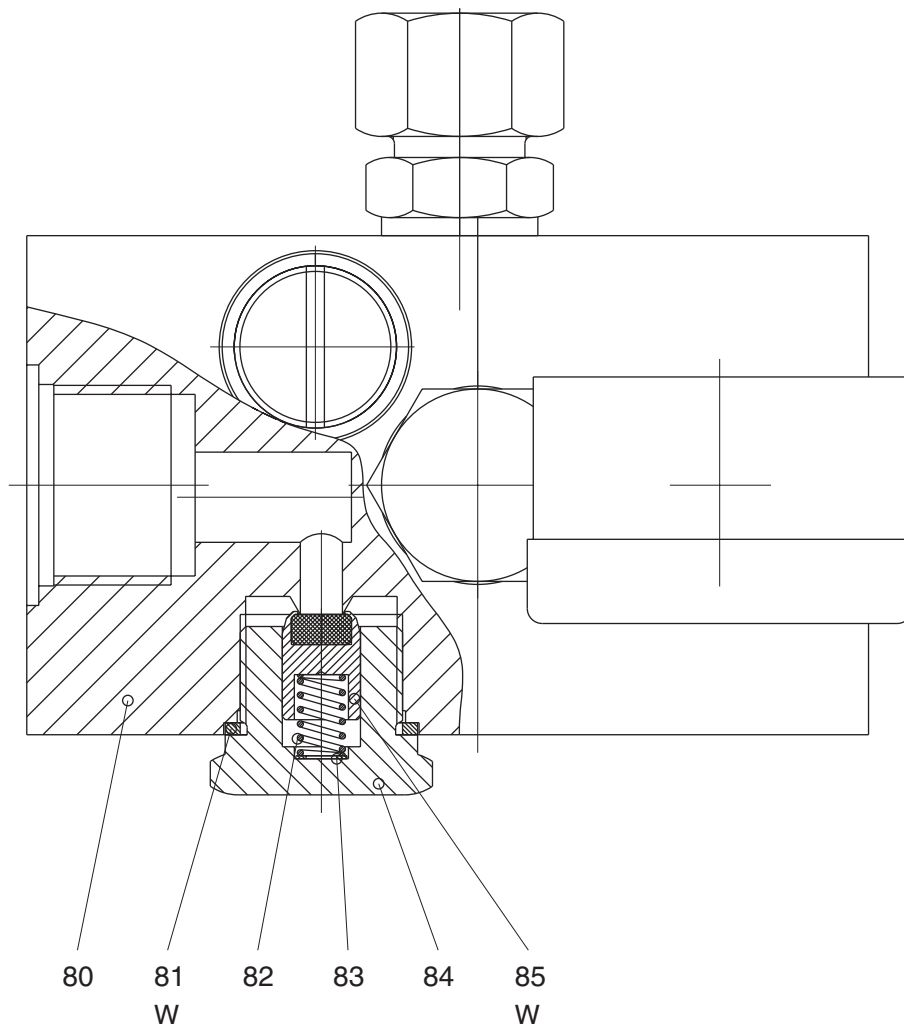

parts marked W are to be kept in stock for maintenance.

4.2 spare parts list RMG 214

pos.-no.	description	amount	W	material	RMG part no.
1	gauge, at option: 0 to 400 bar	1		Ms	00 026 772
	0 to 100 bar	1		Ms	00 026 479
2	intermediate piece	1		St	10 015 185
3	sealing ring at option: 0,5 mm thick	1	W	LM	00 018 788
	1,0 mm thick	1	W	LM	00 018 323
4	sealing ring	1	W	Cu	00 018 586
5	setpoint spring	1		NFSt	10 014 771
6	intermediate piece for spring	1		Ms	10 014 785
7	piston, at option: for valve seat dia. Ø 6 and Ø 8 p _e up to 100 bar	1	W	NSt/Teflon	10 014 764
	p _e above 100 bar for valve seat dia. Ø 11	1	W	NSt/Nylon	10 014 768
	p _e up to 100 bar	1	W	NSt/Teflon	10 014 775
	p _e above 100 bar	1	W	NSt/Nylon	10 014 778
8	valve seat dia., at option: valve seat dia. Ø 6	1		Ms	10 014 761
	valve seat dia. Ø 8	1		Ms	10 014 772
	valve seat dia. Ø 11	1		Ms	10 014 737
9	sealing ring	1	W	Cu	00 003 879
10	guide piece	1		Ms	10 014 740
11	diaphragm, at option: p _a to 10 bar (4 mm thick)	1	W	KG	10 014 757
	p _a to 10 bar (6 mm thick)	1	W	KG	10 014 759
12	sealing ring, at option: p _a to 10 bar (for diaphragm 4 mm thick)	1	W	K	00 018 167
	p _a to 10 bar (for diaphragm 6 mm thick)	1	W	K	00 018 056
13	spring plate, at option: p _a 1 to 5 bar for spring F1 Ø 8	1		St	10 014 746
	p _a 3 to 25 bar for spring F2 Ø 11	1		St	10 014 749
	p _a 5 to 60 bar for spring F3 Ø 14	1		St	10 014 752
	p _a 10 to 80 bar for spring F4 Ø 16	1		St	10 014 755
14	spring, at option: p _a 1 to 5 bar F1 Ø 8	1		FSt	10 014 745
	p _a 3 to 25 bar F2 Ø 11	1		FSt	10 014 748
	p _a 5 to 60 bar F3 Ø 14	1		FSt	10 014 751
	p _a 10 to 80 bar F4 Ø 16	1		FSt	10 014 754
15	lid	1		Ms	10 014 736
16	intermediate piece for spring, at option: p _a 1 to 5 bar for spring F1 Ø 8	1		St	10 014 747
	p _a 3 to 25 bar for spring F2 Ø 11	1		St	10 014 750
	p _a 5 to 60 bar for spring F3 Ø 14	1		St	10 014 753
	p _a 10 to 80 bar for spring F4 Ø 16	1		St	10 014 756
17	setpoint adjusting screw	1		Ms/St	10 014 738

parts marked W are to be kept in stock for maintenance.

material key:

St ... steel

Cu ... copper

FSt ... spring steel

LM ... aluminium

K ... plastic material

NFSt ... inox spring steel

Ms ... brass

KG ... rubber-like plastic material

NSt ... inox steel

pos.- no.	description	amount	W	material	RMG part no.
18	hexagonal nut	1		Ms	18 353 938
19	gauge or Verschluflschraube gauge, at option:				
	0 to 10 bar	1		Ms	00 026 281
	0 to 25 bar	1		Ms	00 026 284
	0 to 60 bar	1		Ms	00 026 283
	0 to 100 bar	1		Ms	00 026 285
	sealing screw	1		Ms	10 014 784
20	sealing ring	1	W	Cu	00 018 512
21	sealing screw	1		Ms	10 014 787
22	sealing ring, at option:				
	0,5 mm thick	1	W	LM	00 018 797
	1 mm thick	1	W	LM	00 018 818
23	body G1	1		Ms	10 014 783
24	adjusting screw	1		Ms	10 014 791
25	counter nut	1		Ms	10 014 797
26	spring, at option:				
	p _a up to 30 bar	1		NFSt	10 014 771
	p _a above 30 bar	1		NFSt	10 014 794
27	screw connection DS 10	1		St	00 030 015
28	sealing ring	1	W	LM	00 018 524
29	piston	1		Ms	10 014 789
30	egalizing piece for spring	1		Ms	10 014 795
31	sealing hub	1	W	KG	00 018 057
50	wire ring	1		NSt	10 015 198
51	sealing washer	1	W	Teflon	10 015 197
52	intermediate piece	1		Ms	10 015 195
53	glide washer	1		Ms	10 015 191
54	sealing ring, at option:				
	2,0 mm thick	1	W	LM	00 018 639
	2,5 mm thick	1	W	LM	00 018 640
	3,0 mm thick	1	W	LM	00 018 641
55	screw connection DS 16	1		St	00 030 008
56	sealing ring	1	W	LM	00 006 608
57	steering pin, complete	1		Ms	10 015 208
80	body G1	1		Ms	10 015 201
81	sealing ring	1	W	LM	00 018 706
82	spring	1		NFSt	10 015 206
83	sealing ring	1		Cu	00 005 121
84	screw connection	1		NSt	10 015 203
85	piston	1	W	NSt/K	10 015 204

parts marked W are to be kept in stock for maintenance.

material key:

St	... steel	Cu	... copper	FSt	... spring steel
LM	... aluminium	K	... plastic material	NFSt	... inox spring steel
Ms	... brass	KG	... rubber-like plastic material	NSt	... inox steel

We supply you with products for gas pressure regulation:



RMG REGEL + MESSTECHNIK GMBH

Osterholzstrasse 45, D-34123 Kassel, Germany
Telephone (++49) 561 5007-0 • Fax (++49) 561 5007-107

gas pressure regulators and safety devices



RMG-GASELAN Regel + Meßtechnik GmbH

Julius-Pintsch-Ring 3, D-15517 Fürstenwalde, Germany
Telephone (++49) 3361 356-60 • Fax (++49) 3361 356-836

gas pressure regulating equipment, displacement meters, complete stations



Bryan Donkin RMG Gas Controls Ltd.

Enterprise Drive, Holmewood, Chesterfield S42 5UZ, England
Telephone (++44) 1246 501-501 • Fax (++44) 1246 501-500

gas pressure regulating equipment, below ground gas control modules



Bryan Donkin RMG Co. of Canada Ltd.

50 Clarke Street South, Woodstock, Ontario N4S 7Y5, Canada
Telephone (++1) 519 5398531 • Fax (++1) 519 5373339

domestic regulators and safety devices

The other RMG Companies:



RMG Messtechnik GmbH

Otto-Hahn-Strasse 5, D-35510 Butzbach, Germany
Telephone (++49) 6033 897-0 • Fax (++49) 6033 897-130

turbine meters, vortex meters, correctors, flow computers, odorizers



Karl Wieser GmbH

Anzinger Strasse 14, D-85560 Ebersberg, Germany
Telephone (++49) 8092 2097-0 • Fax (++49) 8092 2097-10

Betriebsstelle Beindersheim

Heinrich-Lanz-Strasse 9, D-67259 Beindersheim/Pfalz, Germany
Telephone (++49) 6233 3762-0 • Fax (++49) 6233 3762-40

data logging, monitor systems, danger alarm systems



WÄGA Wärme-Gastechnik GmbH

Osterholzstrasse 45, D-34123 Kassel, Germany
Telephone (++49) 561 5007-0 • Fax (++49) 561 5007-207

design and assembly of gas pressure regulating and metering stations

The RMG Group of Companies on the internet: <http://www.rmg.de>

Serving the Gas Industry - WORLDWIDE



We reserve the right for technical changes