

Pressure Reducing Valve RMG 210



**Operation and Maintenance,
Spare Parts**

210.20
edition 10/2004

Serving the Gas Industry - WORLDWIDE



GB

| Contents | | page |
|------------|---|-------------------|
| 1. | General | 3 |
| 1.1 | Safety notes | 3 |
| 2. | Special operating instructions | 4 |
| 2.1 | Adjustment of the intermediate pressure | 4 |
| 3. | Special maintenance instructions | 5 |
| 3.1 | intermediate pressure stage | 5 |
| 3.2 | outlet pressure regulating stage | 5, 6 |
| 3.3 | Screw tightening torques | 6 |
| 3.4 | Lubricants | 6 |
| 4. | Spare parts | |
| 4.1 | Spare part drawings | |
| 4.1.1 | Centre piece with outlet pressure regulating stage type N | 7, 8 |
| 4.1.2 | outlet pressure regulating stage type N, intermediate pressure stage type M | 9 |
| 4.1.3 | outlet pressure regulating stage type M | 9 |
| 4.1.4 | cut-away views | 10 |
| 4.2 | Spare parts lists | 11, 12, 13 |
| 4.3 | Spare parts drawings for gauge connections | |
| 4.3.1 | gauge for outlet pressure | 14 |
| 4.3.2 | gauge for intermediate pressure | 15 |
| 4.4 | Spare parts lists | 16 |
| 4.5 | Parts to be held in stock for maintenance work | 17 |

1. General

Every person engaged with installation, supervision, or maintenance of the gas pressure regulator type RMG 210 is requested to read the following leaflets and brochures beforehand:

- **Technical Description 210.00** - contains technical data, measurements, and describes function and design.
- **General Operating Instructions for Gas Pressure Regulators and Safety Devices** - this RMG brochure describes installation and operation, and includes general hints on fault finding and repair.
- **Operation and Maintenance, Spare Parts 210.20** - contains further details on installation and operation of the gas pressure regulator RMG 210. Maintenance instructions and the spare part drawings and -lists of the main valve are also included.
- The related **functional elements** are described in separate "Operation and Maintenance, Spare Parts"-leaflets:

filter

RMG 905

905.20

Additionally, the relevant national rules and laws have to be observed (In Germany please refer to the DVGW worksheets G 600, G 459/II, G 491 und G 495).

The frequency of periodical maintenance of the gas pressure regulator RMG 512 should be determined according to the prevailing conditions and the type and composition of the gaseous medium. Therefore, no fixed maintenance intervals can be prescribed. For Germany: At the beginning we recommend to use the maintenance intervals stated in the DVGW worksheet G 495. Then individual maintenance intervals should be determined for every station.

For maintenance all parts are to be cleaned and subjected to a thorough visual inspection. A visual inspection should also occur when the course of operation or functional tests have shown lack of regulating accuracy.

Particular care should be given to the checking of sealings and diaphragms, as well as carrying and moving parts. Damaged parts should be replaced by new ones. The item numbers referred to in the maintenance instructions are identical with those of spare part drawings and spare parts lists.

We recommend to keep all parts that are specially marked "W" in the spare parts lists in stock for prompt maintenance availability.

1.1 Safety symbols

Safety symbols include the following **key words** in these operating instructions

| symbols | explanation |
|---------|---|
| | risk of human injury |
| | risk of damaging equipment or environment |
| | additional information or requirements |

2. Special operating instructions

2.1 Adjustment of the intermediate pressure

The height of the intermediate pressure influences the regulating characteristics of the device significantly. To achieve a great regulating accuracy the intermediate pressure should be set as high as possible, but without making the regulating line unstable. Lowering the intermediate pressure can dampen regulating over-reactions, but also reduces the max. possible flow.

The height of the intermediate pressure should be approx. 1 - 2 bar above outlet pressure.

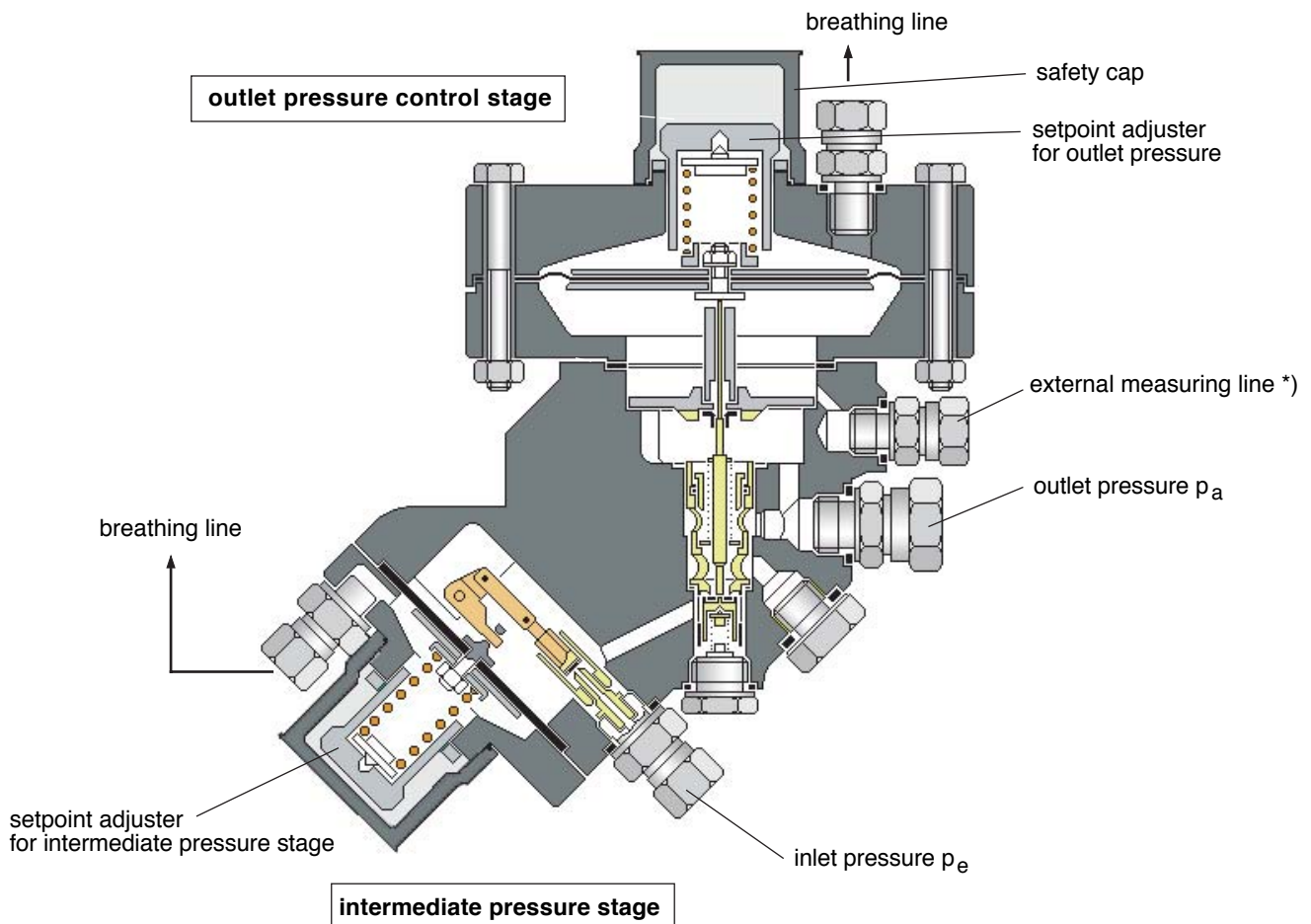

General design of the gas pressure regulator RMG 210 (R 10d)

*) Should the nominal flow be below $q_n < 9 \times p_{a, abs}$, then an external measuring line is not necessary. The connection for the external measuring line can then be blocked using the supplied plug. The outlet pressure measurement is then automatically effected via an internal bore hole.

3. Special maintenance instructions

3.1 Intermediate pressure stage (see page 9)

- **Diaphragm (68)**

For dismantling remove lid (69), then push diaphragm (68) towards the inlet pressure connection (to the left), and bend up this edge of the diaphragm, so that the ring underneath slides off the lever (80).

- **Sealing insert (81)**

For exchange the screws (98) should be loosened and the complete lever system (80) taken out of the body. An indentation on the sealing insert (81) caused by the nozzle (83) is normal. The sealing insert can be removed by levering it out with the help of a needle.

Note

After renewing the sealing insert the position of the assembled lever system has to be checked: Pull the lever outward to push the piston onto the nozzle. The lever should then be parallel to the diaphragm base. If not, then vary the washers (51, 85) under the inlet pressure connection (90), until the correct position is achieved.

- **Nozzle (83)** (see page 10)

Remove the piston guide (82) and check the nozzle tip visually. When using filtered, non-aggressive gases the nozzle tip should be free of pollution or wear. In this case do not dismantle any further.

- **Screw plug (50)** (see page 10)

The screw plug (50) remains screwed tight during maintenance work..

3.2 Outlet pressure stages M and N (see pages 7 and 9)

- **Control pin (16, 76)**

The control pin should glide easily in the bearing.

Note

When adding new parts to the outlet pressure control stage check the adjusting measurement and adjust if necessary (A new control pin might be needed!)

For the correct adjusting measurement please refer to the drawing below:

lid version starting from 8/97

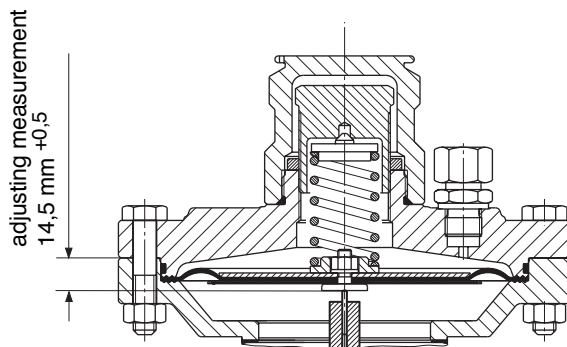

lid version up to 7/97

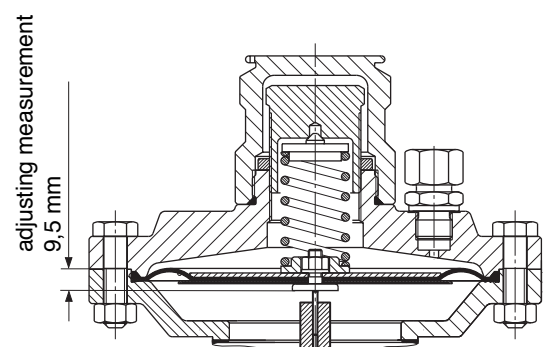

- **control nozzle (28)** (see page 7)

When using filtered, non-aggressive gases the nozzle tip should be free of pollution or wear. No further dismantling is necessary in this case.

Adjusting measurement for outlet pressure control stage M

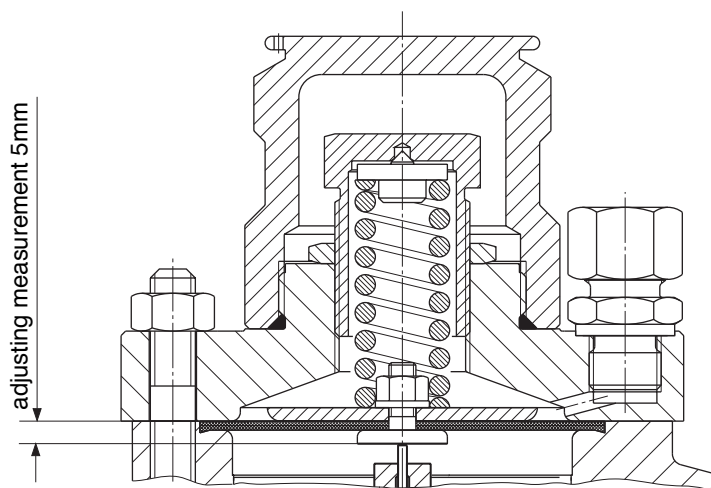

Note

To check the correct height, press the control pin (16, 76) lightly downward to the first stop. In this position, the control rod (20) rests on the piston (23), and the nozzle is still closed. Upon delivery, the control pin has extra length and should be shortened to the correct length before mounting (and sandpaper down any sharp edges!).

- **Piston (23)**

The piston should move freely in the guiding bush.

3.3 Screw tightening torques

| item no. | tightening torque M_A in Nm |
|----------|----------------------------------|
| 9, 61 | 30 |
| 4 | 2,5 |

3.4 Lubricants

| part (to be greased slightly) | lubricant | RMG stock no. |
|--|-----------------|--------------------------|
| all o-rings, all gliding surfaces, all moving parts | silicone grease | 00 027 081 (tube 0,1 kg) |
| regulating screw (33, 73), threads and indentation for spring plate | mounting paste | 00 027 091 |
| all fastening screws and all screwed pipe connections | mounting grease | 00 028 267 |

4.1 Spare part drawings

4.1.1 Centre piece with outlet pressure stage type N

lid version starting from 8/97

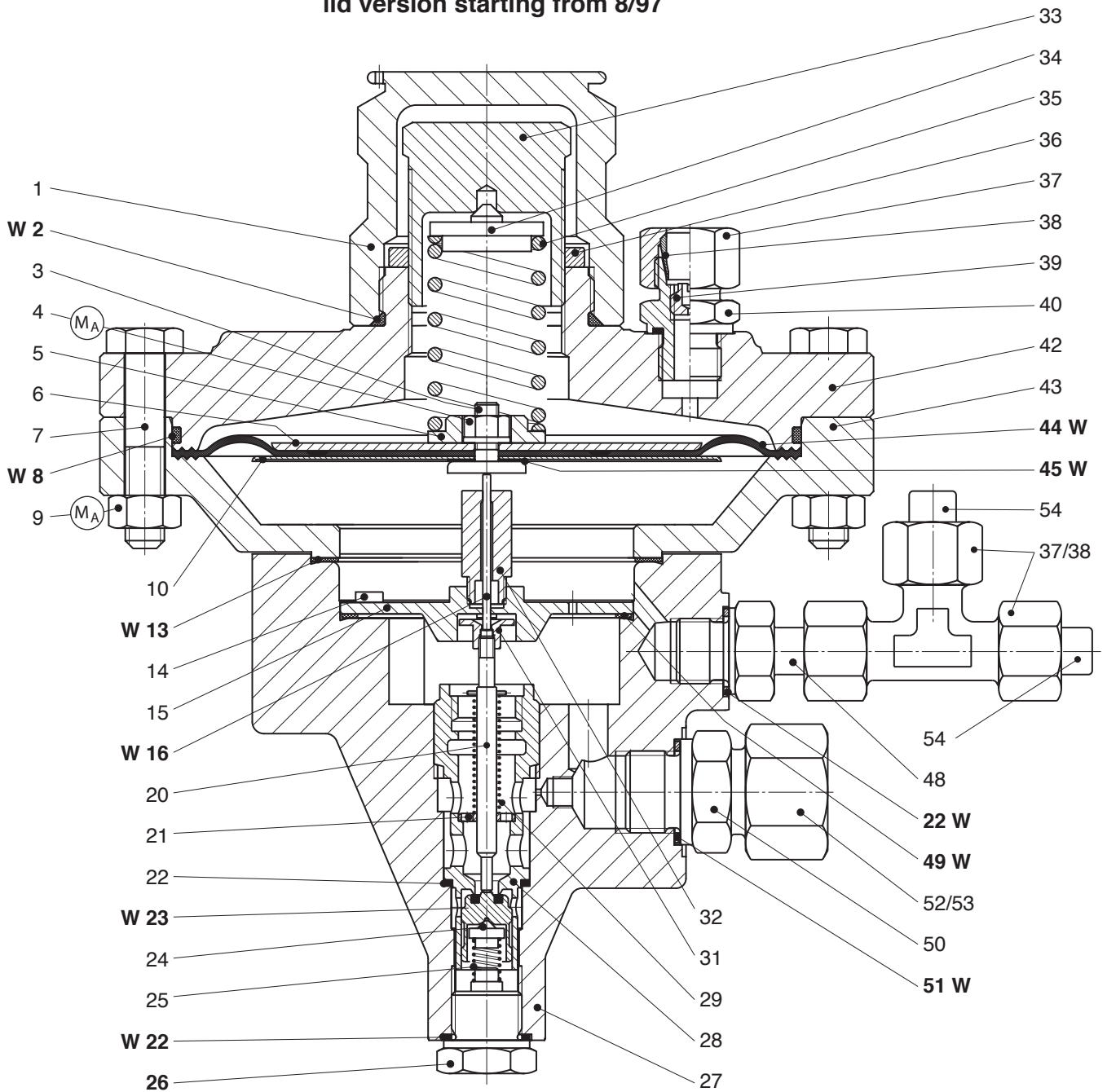

M_A Please note the screw tightening torques on page 6!

W Parts are to be held in stock for maintenance.

outlet pressure stage type N - lid construction up to 7/97

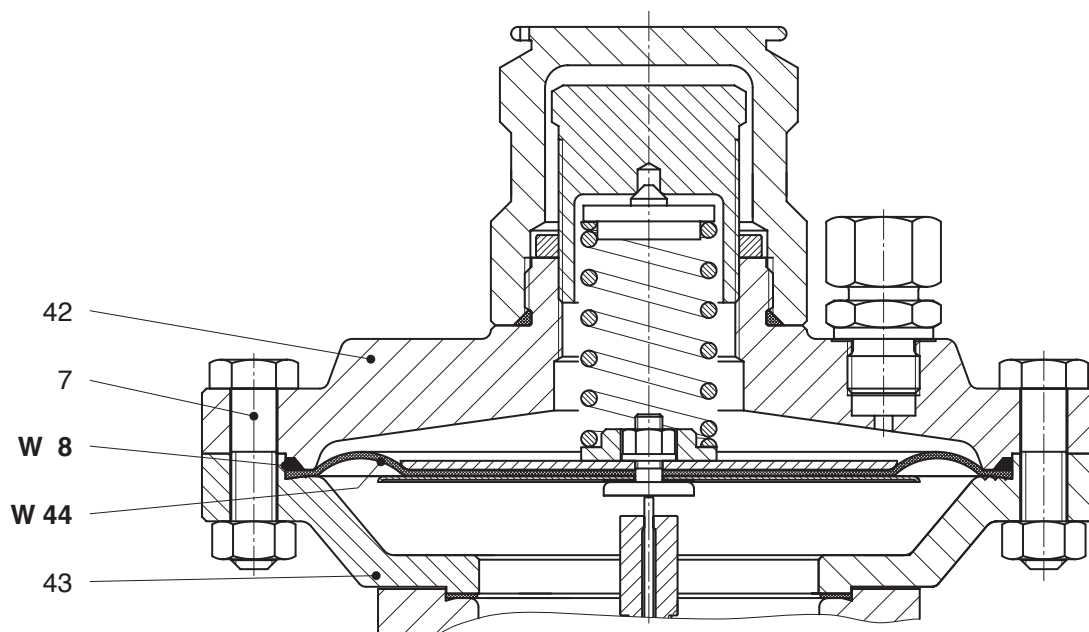

W Parts to be held in stock for maintenance work.

Spare parts list

| item no. | description | amt. | W | material | RMG stock no. |
|-----------|-------------------|----------|----------|-----------|-------------------|
| 7 | hexagonal screw | | | St | 00 010 054 |
| 8 | o-ring | 1 | W | KG | 00 020 353 |
| 42 | lid size N | 1 | | LM | 10 012 137 |
| 43 | intermediate ring | 1 | | LM | 10 017 916 |
| 44 | diaphragm | 1 | W | KG | 10 017 918 |

4.1.2 outlet pressure control stage N, intermediate pressure stage M

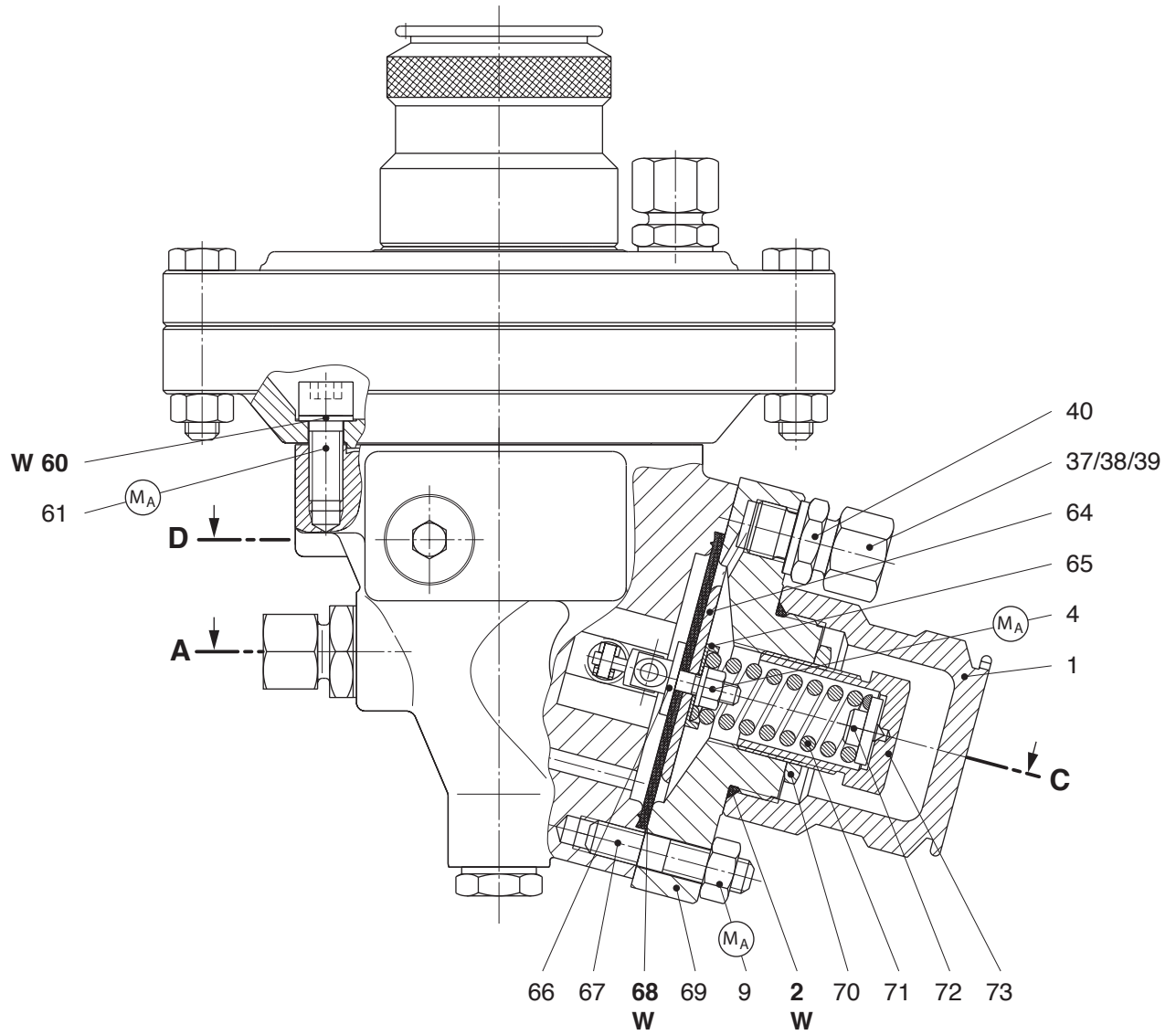

4.1.3 outlet pressure control stage M

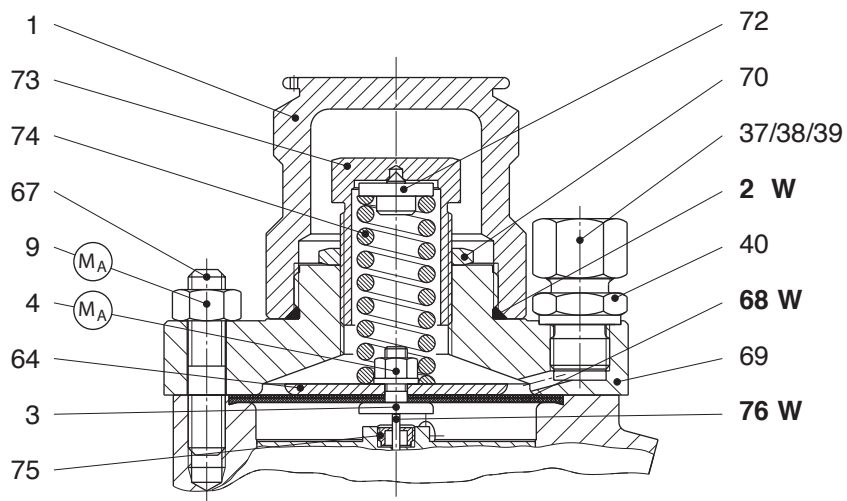

M_A please refer to torque table on page 4!
W parts to be kept in stock for maintenance.

4.1.4 Cut-away views

view A - C

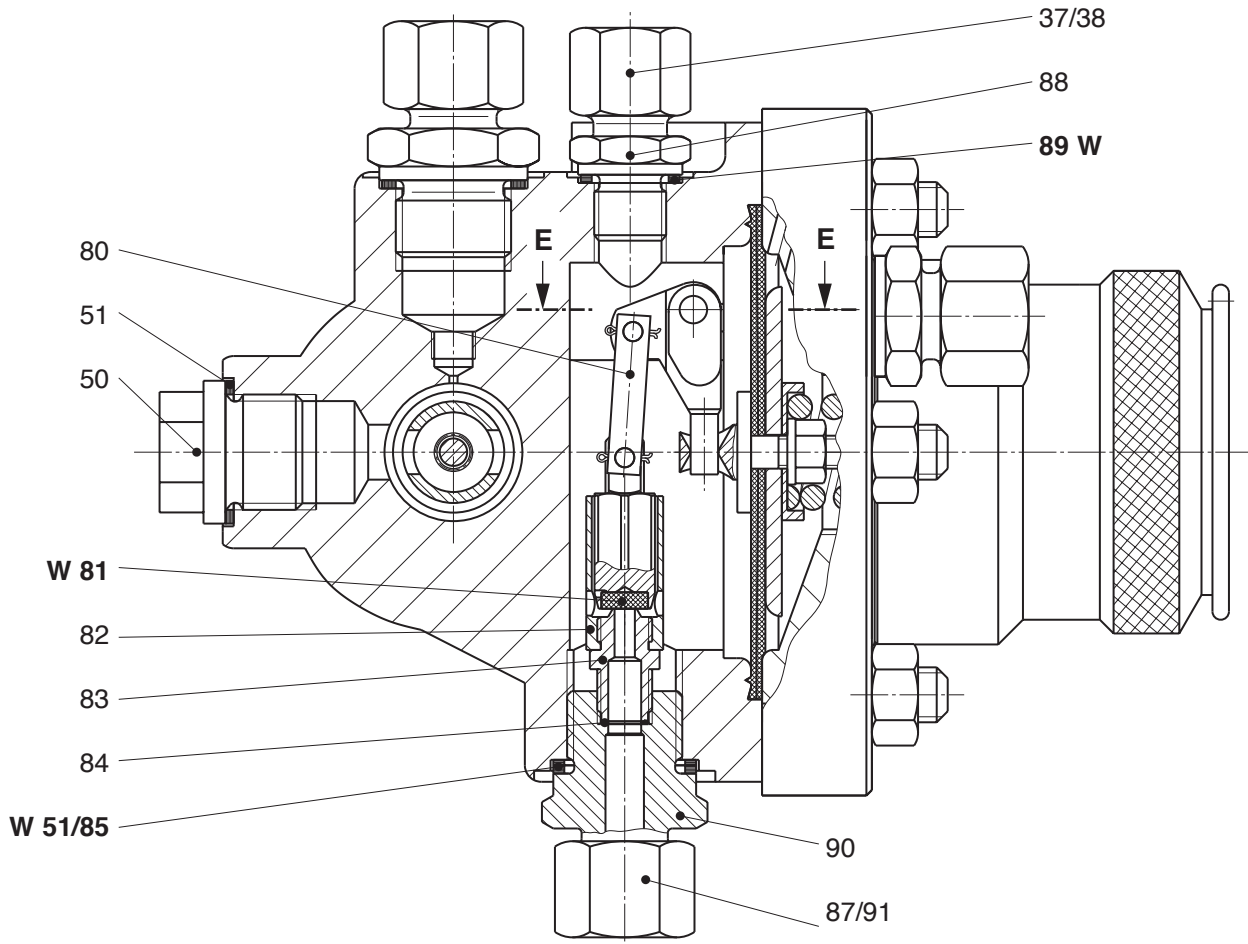

view D

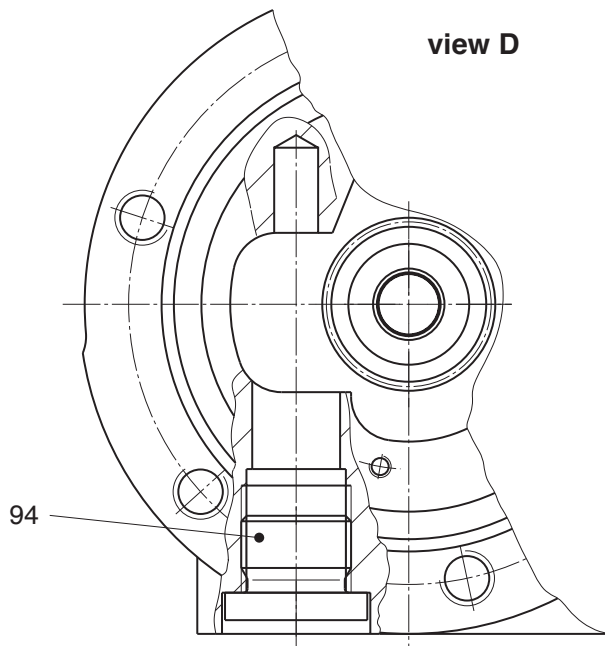

view E - E

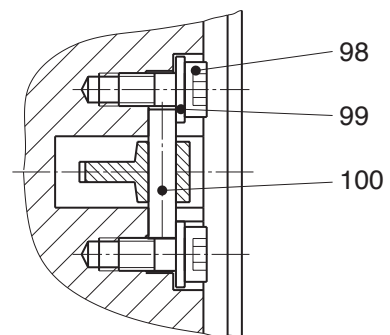

W parts to be held in stock for maintenance.

4.2 Spare part lists

| item no. | description | amount | W | material | RMG stock no. |
|-----------|--|----------|----------|--------------|-------------------|
| 1 | cap | 1 | | LM | 10 012 139 |
| 2 | o-ring | 1 | W | KG | 20 307 |
| 3 | screw | 1 | | St | 10 017 650 |
| 4 | hexagonal nut | 1 | | St | 13 138 |
| 5 | spring plate, at option: | | | | |
| 5 | W _a 10 mbar to 40 mbar | 1 | | LM | 10 016 679 |
| 5 | W _a 20 mbar to 60 mbar | 1 | | LM | 10 017 661 |
| 5 | W _a 40 mbar to 120 mbar | 1 | | LM | 10 017 661 |
| 5 | W _a 80 mbar to 200 mbar | 1 | | LM | 10 017 661 |
| 5 | W _a 100 mbar to 500 mbar | 1 | | LM | 10 016 681 |
| 6 | diaphragm plate | 1 | | St | 10 016 672 |
| 7 | hexagonal screw | 10 | | St | 10 455 |
| 8 | o-ring | 1 | W | KG | 20 324 |
| 9 | hexagonal nut for outlet pressure stage size N | 10 | | St | 5 692 |
| 9 | hexagonal nut for pressure stage size M | 6 | | St | 5 692 |
| 10 | diaphragm plate | 1 | | LM | 10 017 654 |
| 13 | washer | 1 | W | KG | 8 032 |
| 14 | cylindrical screw | 3 | | St | 6 543 |
| 15 | intermediate plate | | | LM | 10 017 588 |
| 16 | control pin (40,5 mm long) | 1 | W | NSt | 10 017 926 |
| 20 | control rod | 1 | | Ms | 10 017 603 |
| 21 | guiding washer | 1 | | Ms | 10 017 610 |
| 22 | washer | 3 | W | LM | 18 688 |
| 23 | piston, complete | 1 | W | LM/KG | 10 017 616 |
| 24 | spring compensating piece | 1 | | LM | 10 017 614 |
| 25 | spring | 1 | | FSt | 10 017 639 |
| 26 | screw plug | 1 | | Ms | 10 017 606 |
| 27 | body | 1 | | LM | 10 024 341 |
| 28 | control nozzle | 1 | W | LM | 10 017 596 |
| 29 | spring | 1 | | NFSt | 10 014 020 |
| 31 | intermediate piece | 1 | | LM | 10 017 600 |
| 32 | sealing screw | 1 | | Ms | 10 017 923 |
| 33 | adjusting screw | 1 | | Ms | 10 012 140 |

W parts to be held in stock for maintenance

material key

| | | |
|--|---------------------------|--|
| St ... steel | LM ... light metal | SSt ... plastic foam |
| NSt ... stainless steel | Ms ... brass | K ... plastic material |
| FSt ... spring steel | Cu ... copper | KG ... rubber-like plastic material |
| NFSt ... stainless spring steel | Bz ... bronze | KGFP ... rubber-like plastic material with coating |
| GS ... cast steel | GLM ... cast light metal | FPM ... special rubber-like plastic material |
| GGG ... cast iron with globular graphite | GMs ... cast brass | FP ... special plastic material |
| GZn ... cast zinc | AlBz ... aluminium bronze | PGL ... plexiglass |
| GBz ... cast bronze | | |

| item no. | description | Anz. | W | Werkst. | Teile - Nummer |
|-----------|--|----------|----------|--------------|-------------------|
| 34 | spring compensating piece, at option: | | | | |
| 34 | W _a 10 mbar to 40 mbar | 1 | | St | 10 014 931 |
| 34 | W _a 20 mbar to 60 mbar | 1 | | St | 10 014 931 |
| 34 | W _a 40 mbar to 120 mbar | 1 | | St | 10 014 931 |
| 34 | W _a 80 mbar to 200 mbar | 1 | | St | 10 014 933 |
| 34 | W _a 100 mbar to 500 mbar | 1 | | St | 10 014 933 |
| 35 | spring, at option: | | | | |
| 35 | W _a 10 mbar to 40 mbar | 1 | | FSt | 10 014 926 |
| 35 | W _a 20 mbar to 60 mbar | 1 | | FSt | 10 015 469 |
| 35 | W _a 40 mbar to 120 mbar | 1 | | FSt | 10 016 660 |
| 35 | W _a 80 mbar to 200 mbar | 1 | | FSt | 10 014 516 |
| 35 | W _a 100 mbar to 500 mbar | 1 | | FSt | 10 015 161 |
| 36 | threaded ring | 1 | | LM | 10 014 900 |
| 37 | cap nut | 4 | | St | 30 804 |
| 38 | compression joint | 5 | | St | 30 904 |
| 39 | dosing screw | 1 | | Ms | 10 005 096 |
| 40 | threaded adapter | 1 | | St/KG | 10 024 347 |
| 42 | lid N (starting from 8/97) | 1 | | LM | 10 012 141 |
| 43 | intermediate ring (starting from 8/97) | 1 | | LM | 10 012 142 |
| 44 | diaphragm | 1 | W | KG | 10 017 918 |
| 45 | washer | 1 | W | KG | 8 068 |
| 48 | connecting piece | 1 | | St | 32 633 |
| 49 | washer | 1 | W | KG | 10 017 612 |
| 50 | screw plug | 1 | | St | 30 106 |
| 51 | washer (1,5 mm thick) | 1 | W | LM | 18 815 |
| 52 | cap nut | 1 | | St | 30 807 |
| 53 | compression joint | 1 | | St | 30 906 |
| 54 | cap (only for internal measuring) | 2 | | | 32 005 |
| 60 | USIT ing | 6 | W | St/KG | 27 858 |
| 61 | cylindrical screw | 6 | | St | 10 207 |
| 64 | diaphragm plate | 1 | | St | 10 014 983 |
| 65 | spring guiding plate | 1 | | LM | 10 017 697 |
| 66 | ring screw | 1 | | NSt | 10 014 993 |
| 67 | threaded dowel | 6 | | St | 12 203 |
| 68 | diaphragm | 1 | W | KG | 10 014 989 |
| 69 | lid M | 1 | | LM | 10 012 138 |
| 70 | nut | 1 | | St | 10 014 996 |

| item no. | description | amount | W | material | RMG stock no. |
|-----------|-----------------------------------|----------|----------|------------|-------------------|
| 71 | spring | 1 | | FSt | 10 015 005 |
| 72 | spring compensating piece | 1 | | St | 10 016 656 |
| 73 | regulating screw | 1 | | Ms | 10 014 999 |
| 74 | spring, at option: | | | | |
| 74 | W _a 0,3 bar to 1,5 bar | 1 | | FSt | 10 016 654 |
| 74 | W _a 1,0 bar to 2,5 bar | 1 | | FSt | 10016 655 |
| 74 | W _a 2,0 bar to 3,5 bar | 1 | | FSt | 10 015 005 |
| 75 | sealing screw | 1 | | Ms | 10 017 688 |
| 76 | control pin (17 mm long) | 1 | W | NSt | 10 017 691 |
| 80 | lever system, pre-assembled | 1 | | Ms/NSt | 10 014 452 |
| 81 | sealing insert | 1 | W | KG | 10 014 474 |
| 82 | piston guide | 1 | | Ms | 10 014 471 |
| 83 | nozzle | 1 | W | Ms | 10 014 466 |
| 84 | washer | 1 | W | LM | 18 811 |
| 85 | washer (1,0 mm dick) | 1 | W | LM | 18 814 |
| 85 | washer (2,0 mm dick) | 1 | W | LM | 18 849 |
| 86 | cap nut | 1 | | St | 30 803 |
| 87 | compression joint | 1 | | St | 30 903 |
| 88 | connecting piece | 1 | | St | 30 110 |
| 89 | washer | 1 | W | LM | 18 689 |
| 90 | adapter | 1 | | LM | 10 018 459 |
| 91 | cap nut | 1 | | St | 30 804 |
| 94 | sealing screw | 1 | | St | 32 017 |
| 98 | cylindrical screw | 2 | | St | 10 596 |
| 99 | washer | 2 | | St | 8 279 |
| 100 | bolt | 1 | | St | 10 020 042 |

4.3.1 Gauge for outlet pressure

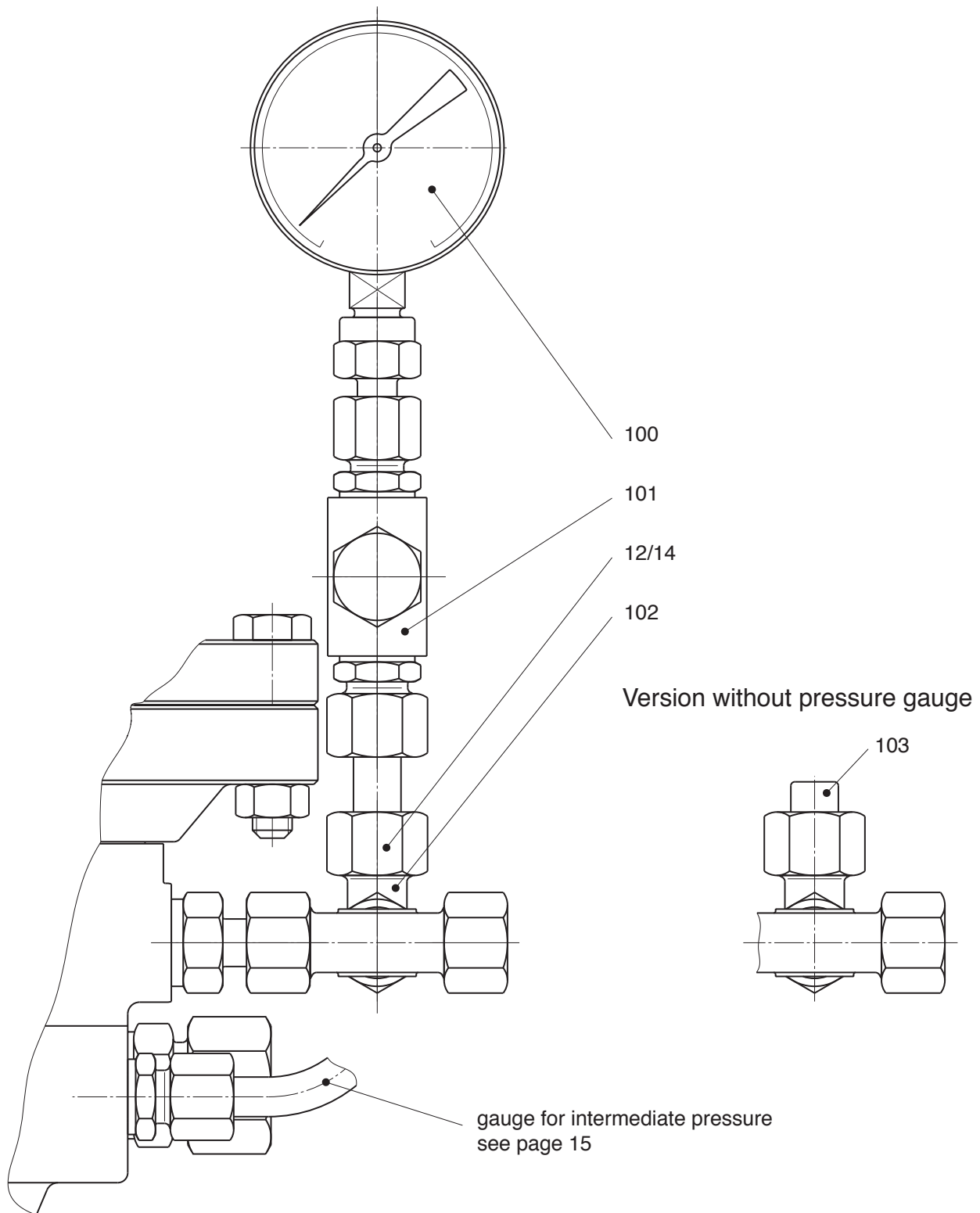

4.3.2 Gauge for intermediate pressure

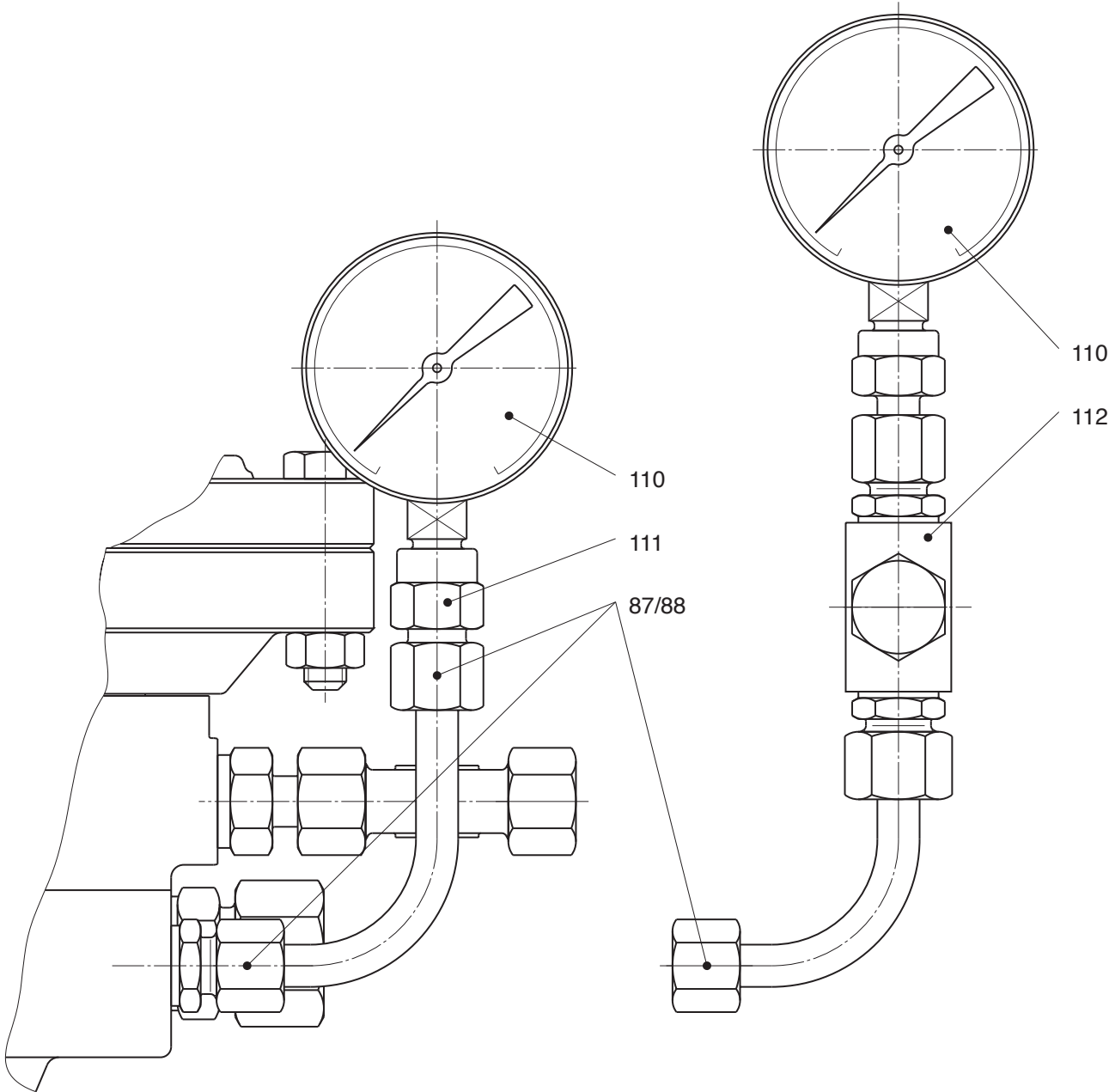

4.4 Spare parts list

| item no. | desxcription | amount | W | material | RMG stock no. |
|--|--|--------|---|----------|---------------|
| gauge for outlet pressure | | | | | |
| 100 | pressure gauge, at option: | | | | |
| 100 | Wa 0,3 bar to 1,5 bar | 1 | | St/Ms | 27 191 |
| 100 | Wa 1,0 bar to 3,5 bar | 1 | | St/Ms | 26 891 |
| 101 | overpressure safety valve, at option: | | | | |
| 101 | RMG 925 for 2,5 bar | 1 | | | 89 252 404 |
| 101 | RMG 925 for 6,0 bar | 1 | | | 89 252 406 |
| 102 | adapter | 1 | | St | 31 213 |
| 102 | plug (for version without outlet pressure gauge) | 1 | | St | 32 005 |
| gauge for intermediate pressure | | | | | |
| 110 | pressure gauge | 1 | | St/Ms | 26 281 |
| 111 | adapter | 1 | | St | 31 865 |
| 112 | overpressure safety valve | 1 | | | 89 251 407 |

4.5 Parts to be held in stock for maintenance

| item no. | description | amt. | material | RMG stock no. |
|----------|--------------------------|------|----------|---------------|
| 2 | o-ring | 1 | KG | 20 307 |
| 8 | o-ring | 1 | KG | 20 324 |
| 13 | washer | 1 | KG | 8 032 |
| 16 | pin (40,5 mm long) | 1 | NSt | 10 017 926 |
| 23 | piston, complete | 1 | LM/KG | 10 017 616 |
| 44 | diaphragm | 1 | KG | 10 017 918 |
| 45 | washer | 1 | KG | 8 068 |
| 49 | washer | 1 | KG | 10 017 612 |
| 60 | USIT ring | 6 | St/KG | 27 858 |
| 68 | diaphragm | 1 | KG | 10 014 989 |
| 76 | control pin (17 mm long) | 1 | NSt | 10 017 691 |
| 81 | sealing insert | 1 | KG | 10 014 474 |
| 85 | washer (1,0 mm thick) | 1 | LM | 18 814 |
| 85 | washer (2,0 mm thick) | 1 | LM | 18 849 |
| 89 | washer | 1 | LM | 18 689 |

We supply you with products for gas pressure regulation:



RMG REGEL + MESSTECHNIK GMBH

Osterholzstrasse 45, D-34123 Kassel, Germany
Telephone (+49) 561 5007-0 • Fax (+49) 561 5007-107
gas pressure regulators and safety devices



RMG-GASELAN Regel + Meßtechnik GmbH

Julius-Pintsch-Ring 3, D-15517 Fürstenwalde, Germany
Telephone (+49) 3361 356-60 • Fax (+49) 3361 356-836
gas pressure regulating equipment, displacement meters, complete stations



Bryan Donkin RMG Gas Controls Ltd.

Enterprise Drive, Holmewood, Chesterfield S42 5UZ, England
Telephone (+44) 1246 501-501 • Fax (+44) 1246 501-500
gas pressure regulating equipment, below ground gas control modules



Bryan Donkin RMG Co. of Canada Ltd.

50 Clarke Street South, Woodstock, Ontario N4S 7Y5, Canada
Telephone (+1) 519 5398531 • Fax (+1) 519 5373339
domestic regulators and safety devices

The other RMG Companies:



RMG Messtechnik GmbH

Otto-Hahn-Strasse 5, D-35510 Butzbach, Germany
Telephone (+49) 6033 897-0 • Fax (+49) 6033 897-130
turbine meters, vortex meters, correctors, flow computers, odorizers



Karl Wieser GmbH

Anzinger Strasse 14, D-85560 Ebersberg, Germany
Telephone (+49) 8092 2097-0 • Fax (+49) 8092 2097-10
works Beindersheim
Heinrich-Lanz-Strasse 9, D-67259 Beindersheim/Pfalz, Germany
Telephone (+49) 6233 3762-0 • Fax (+49) 6233 3762-40
data logging, monitor systems, danger alarm systems



WÄGA Wärme-Gastechnik GmbH

Osterholzstrasse 45, D-34123 Kassel, Germany
Telephone (+49) 561 5007-0 • Fax (+49) 561 5007-207
design and assembly of gas pressure regulating and metering stations



ZUG GAZOMET Sp. z o.o.

ul. Sarnowska 2, 63-900 Rawicz, Poland
Telephone (+48) 65 546 24 01 • Fax (+48) 65 546 24 08
ball valves, accessories, gas pressure regulating and metering stations

The RMG Group of Companies on the internet: <http://www.rmg.de>

Serving the Gas Industry - WORLDWIDE



We reserve the right for technical changes