

Flame Arresters/Vents

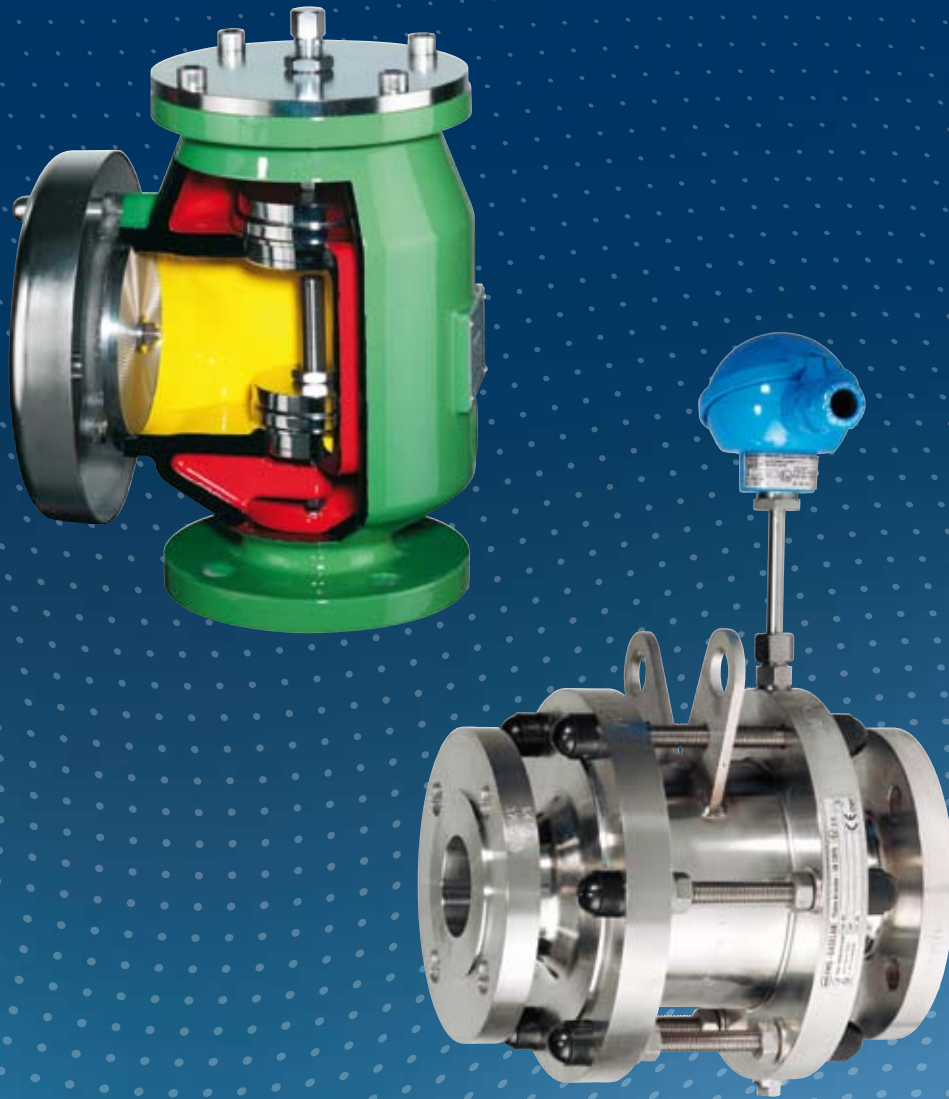

PRODUCT INFORMATION

**Serving the Gas Industry
Worldwide**



RMG-GASELAN Regel- und Messtechnik GmbH is a company based in Germany. We produce devices and safety systems recommended for use in explosive areas. We are a certified manufacturer of flame arresters with and without vent function.

All products have been certified through a certification body (BAM, IBExU, PTB) as per the EC Directive 94/9/EC and awarded the CE mark of conformity.

Our modern measuring technique guarantees objective testing of parameters relevant to safety and a uniform high quality maintained by specially trained technical experts. A complete documentation of all statutory (EN 10204) parameters and those individually requested by our customers complete our product palette.

In the capacity of an accredited certification body, the BAM (Federal Institute for Materials Research and Testing) reexamined our quality assurance system for production and awarded a relevant certification.

Our flame arresters and vents incorporate impressive features including compact and light design, minimum pressure losses and variable flowrate in the same connection nominal diameter. The easy-to-disassemble design ensures a quick replacement of spare parts.



Assembling

Flame arresters

Flame arresters are used as secondary protection against explosions by preventing the transmission of flame and explosion transfer in machines, equipment and plant, containing inflammable gas or steam-air mixtures of inflammable liquids. These autonomous safety systems limit the effects of the explosions, rendering them harmless, they are intended to allow flow but prevent flame transmission.

We follow the principle of 'quenching gap' in developing and designing flame arresters. This principle is implemented through dry flame arrester elements. Depending on the process requirement, the flame arrester elements comprising of metal foil elements with defined joints in gaps are designed in different configuration.

Our spectrum of products in the field of flame arresters includes deflagration end-of-line and in-line flame arresters and detonation in-line flame arresters.



Metal foil element

Deflagration

A deflagration is an explosive combustion process in which the flames propagate at subsonic velocity. There are end-of-line and in-line deflagration flame arresters. It is imperative to adhere to the maximum distance (L) from the ignition source when installing in-line flame arresters.

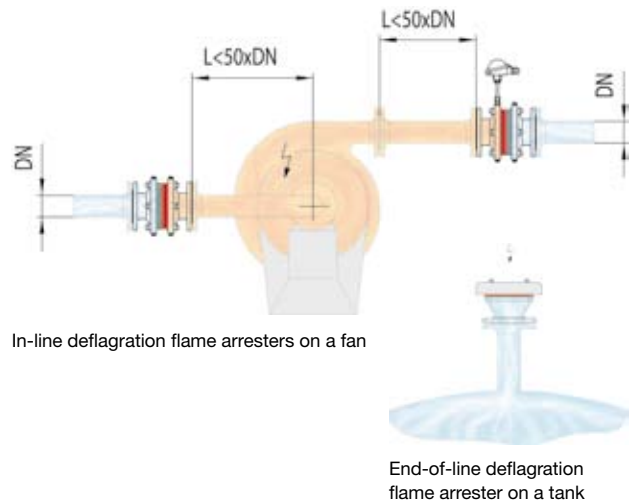

In-line deflagration flame arresters on a fan

End-of-line deflagration flame arrester on a tank

Detonation

A detonation is an explosion propagating at supersonic velocity characterized by a shock wave. Detonations occur in pipelines with long distances to the ignition source ($L > 50 \times DN$ being an example for explosion group IIA).

The flame arresting effect and mechanical carrying capacity in in-line detonation flame arresters is substantially more than that in the in-line deflagration flame arresters. This equips them for use in protection against deflagrations as well.

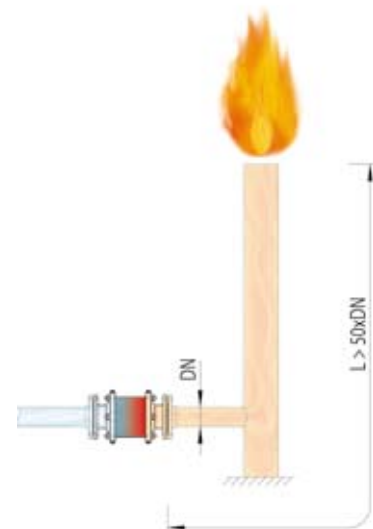

In-line detonation flame arrester on a flare

Stabilized burning

Stabilized burning is the steady burning of a flame near or on the flame arrester element. A large part of our flame arresters is designed for short time or endurance burning.

Our short time burning flame arresters have an integrated temperature sensor for monitoring the temperature. If a pre-determined limit value is overshoot during the process, an emergency operation must be initiated by the operator within a defined period.

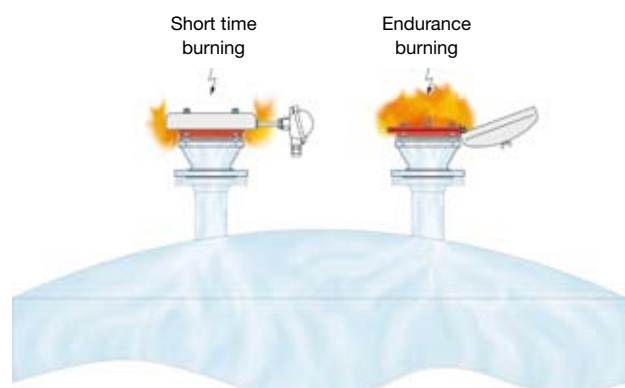

End-of-line flame arresters on a tank

Vents without flame arrester element

Vents are used for independent ventilation of vessels and storage tanks and therefore offer safety from impermissible pressure and vacuum.

Our vents have weight loaded valve discs which attain their full valve lift as soon as pressures exceed 10% of the set pressure. This enables us to offer the customer maximum performance with lowest product losses.

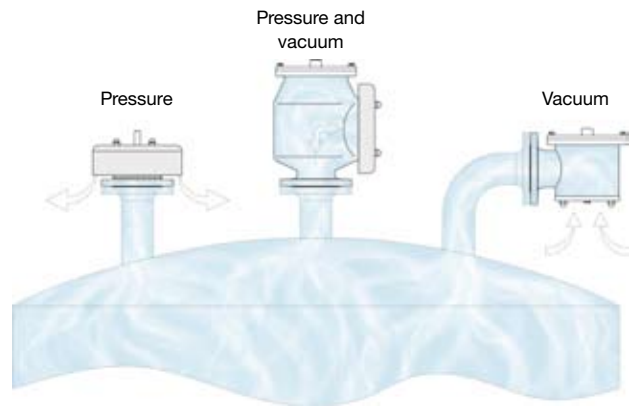

Breather vents on a tank

Standard valve seats, discs and spindles are manufactured from corrosion-resistant material. For reducing the leak rates, the sealing between valve disc and seat is made of a sealing foil and an air cushion over it. The sealing is made of metal if set pressures are high.

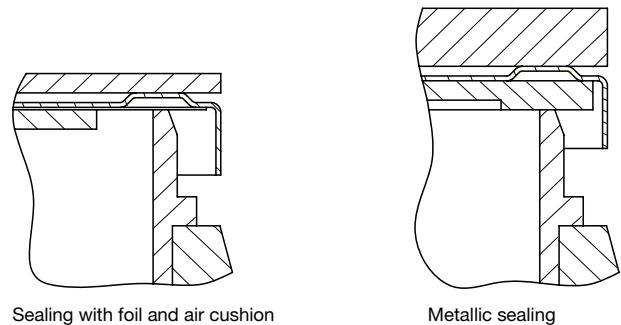

Sealing with foil and air cushion

Metallic sealing

The suitability of all vents used in explosive atmospheres has been proved in an ignition hazard assessment. As devices of Device Group II Category 1G, they are approved for use in vessels and equipment with inflammable mixtures.

Vents including flame arrester element

The weight loaded pressure and vacuum vents are additionally equipped with flame arrester elements. In addition to the test as device for inflammable mixtures, the vents have also been tested and certified as safety systems in accordance with the Directive 94/9/EC.

The combination of vent and flame arrester element joined the merits of the two systems in a single compact device.

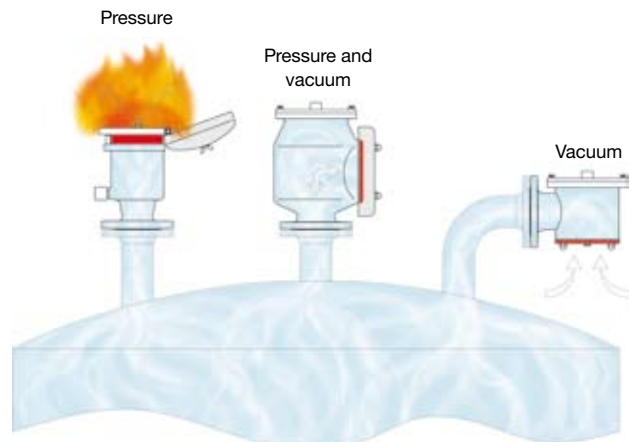

Breather vents including flame arrester element on a tank

In-line deflagration flame arrester in accordance with ATEX 95 and EN 12874	explosion group		
	IIC (B) (MESG < 0.50)	IIB3 (C) (MESG ≥ 0.65)	IIA (D) (MESG > 0.90)
Deflagration	○	○	○
Stable detonation	○	○	○
Unstable detonation		○	○



RMG 931

RMG 931	deflagration, stable and unstable detonation endurance burning
application	gas/air- or vapour/air-mixtures of the explosion groups: IIA, I (methane)
nom. diameter	8 10 15 20 25 32 ¼" ⅜" ½" ¾" 1" 1¼"
connection	Rp to ISO 7-1 (DIN 2999), BSP to BS 21, NPTF to ANSI B1.20.3
metal foil element	stainless steel
body/cover	carbon steel, stainless steel



RMG 931-A

RMG 931-A	deflagration, stable and unstable detonation endurance burning
application	gas/air- or vapour/air-mixtures of the explosion groups: IIA, I (methane)
nom. diameter	15 20 25 32 ½" ¾" 1" 1¼"
connection	DIN 2501 PN10 ANSI B16.5 - 150 RF
metal foil element	stainless steel
body/cover	carbon steel, stainless steel



RMG 931-B

RMG 931-B	deflagration, stable and unstable detonation
application	gas/air- or vapour/air-mixtures of the explosion groups: IIC, IIB3, IIA, I (methane)
nom. diameter	6 8 10 15 ⅛" ¼" ⅜" ½"
connection	Rp to ISO 7-1 (DIN 2999), BSP to BS 21, NPTF to ANSI B1.20.3
metal foil element	stainless steel, special alloy
body/cover	stainless steel, special alloy



RMG 931-T

RMG 931-T	deflagration short time burning
application	gas/air- or vapour/air-mixtures of the explosion groups: IIA, I (methane)
nom. diameter	40 1½"
connection	Rp to ISO 7-1 (DIN 2999), BSP to BS 21, NPTF to ANSI B1.20.3
metal foil element	stainless steel
body/cover	carbon steel, stainless steel



RMG 931-A-T

RMG 931-A-T	deflagration short time burning
application	gas/air- or vapour/air-mixtures of the explosion groups: IIA, I (methane)
nom. diameter	40 1½"
connection	DIN 2501 PN10 ANSI B16.5 - 150 RF
metal foil element	stainless steel
body/cover	carbon steel, stainless steel



RMG 933-G

RMG 933-G	deflagration, stable and unstable detonation short time burning
application	gas/air- or vapour/air-mixtures of the explosion groups: IIC, IIB3, IIA, I (methane)
nom. diameter	25 32 40 50 65 80 1" 1¼" 1½" 2" 2½" 3"
connection	Rp to ISO 7-1 (DIN 2999), BSP to BS 21, NPTF to ANSI B1.20.3
metal foil element	stainless steel, special alloy
housing of metal foil elements	stainless steel, special alloy
body	carbon steel, stainless steel, special alloy



RMG 933-A

RMG 933-A	deflagration, stable and unstable detonation short time burning
application	gas/air- or vapour/air-mixtures of the explosion groups: IIC, IIB3, IIA, I (methane)
nom. diameter	25 32 40 50 65, 80 1" 1¼" 1½" 2" 2½" 3"
connection	DIN 2501 PN10 ANSI B16.5 - 150 RF
metal foil element	stainless steel, special alloy
housing of metal foil elements	stainless steel, special alloy
body	carbon steel, stainless steel, special alloy



RMG 933-S

RMG 933-S	deflagration, stable and unstable detonation short time burning
application	gas/air- or vapour/air-mixtures of the explosion groups: IIC, IIB3, IIA, I (methane)
nom. diameter	50 65 80 100 125 150 200 250 300 350 400 2" 2½" 3" 4" 5" 6" 8" 10" 12" 14" 16"
connection	ISO 7005 PN10 ANSI B16.5 - 150 RF
metal foil element	stainless steel, special alloy
housing of metal foil elements	stainless steel, special alloy
body	ductile iron, carbon steel, stainless steel, special alloy
feature	additional nuts for easy dismanteling the flame arrester element



RMG 933-SE

RMG 933-SE	deflagration, stable detonation short time burning							
application	gas/air- or vapour/air-mixtures of the explosion groups: IIA, I (methane)							
nom. diameter	50	80	100	125	150	200	250	
	2"	3"	4"	5"	6"	8"	10"	
connection	ISO 7005 PN10 ANSI B16.5 - 150 RF							
metal foil element	stainless steel, special alloy							
housing of metal foil elements	stainless steel, special alloy							
body	ductile iron, carbon steel, stainless steel							
feature	additional nuts for easy dismantling the flame arrester element							

End-of-line deflagration flame arrester in accordance with ATEX 95 and EN 12874	explosion group		
	IIC (B) (MESG < 0.50)	IIB3 (C) (MESG ≥ 0.65)	IIA (D) (MESG > 0.90)
Deflagration	○	○	○
Deflagration and short time burning	○	○	○
Deflagration and endurance burning		○	○



RMG 934-BM

RMG 934-BM	deflagration endurance burning			
application	gas/air- or vapour/air-mixtures of the explosion groups: IIB3, IIA, I (methane)			
nom. diameter	40	50	65	80
	1½"	2"	2½"	3"
connection	ISO 7005 PN10, ANSI B16.5 - 150 RF, Rp to ISO 7-1 (DIN 2999), BSP to BS 21, NPTF to ANSI B1.20.3			
material	carbon steel, stainless steel			



RMG 934-BP

RMG 934-BP	deflagration endurance burning			
application	gas/air- or vapour/air-mixtures of the explosion groups: IIA, I (methane)			
nom. diameter	25	32	40	50
	1"	1¼"	1½"	2"
connection	ISO 7005 PN10, ANSI B16.5 - 150 RF, Rp to ISO 7-1 (DIN 2999), BSP to BS 21, NPTF to ANSI B1.20.3			
material	carbon steel, stainless steel, plexiglas			



RMG 934-B-E

RMG 934-B-E	deflagration												
application	gas/air- or vapour/air-mixtures of the explosion groups: IIC, IIB3, IIA, I (methane)												
nom. diameter	25	32	40	50	65	80	100	125	150	200	250	300	
	1"	1¼"	1½"	2"	2½"	3"	4"	5"	6"	8"	10"	12"	
connection	ISO 7005 PN10, ANSI B16.5 - 150 RF, Rp to ISO 7-1 (DIN 2999), BSP to BS 21, NPTF to ANSI B1.20.3												
material	carbon steel, stainless steel, special alloy												



RMG 934-B-T

RMG 934-B-T	deflagration short time burning
application	gas/air- or vapour/air-mixtures of the explosion groups: IIC, IIB3, IIA, I (methane)
nom. diameter	25 32 40 50 65 80 100 125 150 200 250 300 1" 1¼" 1½" 2" 2½" 3" 4" 5" 6" 8" 10" 12"
connection	ISO 7005 PN10, ANSI B16.5 - 150 RF, Rp to ISO 7-1 (DIN 2999), BSP to BS 21, NPTF to ANSI B1.20.3
material	carbon steel, stainless steel, special alloy



RMG 934-BP-E

RMG 934-BP-E	deflagration
application	gas/air- or vapour/air-mixtures of the explosion groups: IIC, IIB3, IIA, I (methane)
nom. diameter	25 32 40 50 65 80 100 125 150 200 1" 1¼" 1½" 2" 2½" 3" 4" 5" 6" 8"
connection	ISO 7005 PN10, ANSI B16.5 - 150 RF, Rp to ISO 7-1 (DIN 2999), BSP to BS 21, NPTF to ANSI B1.20.3
material	carbon steel, stainless steel, special alloy, plexiglas



RMG 934-BP-T

RMG 934-BP-T	deflagration short time burning
application	gas/air- or vapour/air-mixtures of the explosion groups: IIC, IIB3, IIA, I (methane)
nom. diameter	25 32 40 50 65 80 100 125 150 200 1" 1¼" 1½" 2" 2½" 3" 4" 5" 6" 8"
connection	ISO 7005 PN10, ANSI B16.5 - 150 RF, Rp to ISO 7-1 (DIN 2999), BSP to BS 21, NPTF to ANSI B1.20.3
material	carbon steel, stainless steel, special alloy, plexiglas

End-of-line breather vent incl. flame arrester element in accordance with ATEX 95, EN13463-1, EN13463-5 and EN12874		explosion group	
		IIB3 (C) (MESG ≥ 0.65)	IIA (D) (MESG > 0.90)
Deflagration	pressure vent	○	○
	vacuum vent	○	○
	pressure and vacuum vent	○	○
Deflagration with endurance burning	pressure vent	○	○
	pressure and vacuum vent	○	○



RMG 935

RMG 935	
	pressure vent deflagration and endurance burning
application	gas/air- or vapour/air-mixtures of the explosion groups: IIA, I (methane)
nom. diameter	50 80 2" 3"
connection	ISO 7005 PN10 ANSI B16.5 - 150 RF
valve set	stainless steel, special alloy
body	ductile iron, stainless steel



RMG 935-E

RMG 935-E	
	pressure vent deflagration
application	gas/air- or vapour/air-mixtures of the explosion groups: IIB3, IIA, I (methane)
nom. diameter	50 80 2" 3"
connection	ISO 7005 PN10 ANSI B16.5 - 150 RF
valve set	stainless steel, special alloy
body	ductile iron, stainless steel



RMG 936-E

RMG 936-E	
	vacuum vent deflagration
application	gas/air- or vapour/air-mixtures of the explosion groups: IIB3, IIA, I (methane)
nom. diameter	50 80 100 150 200 2" 3" 4" 6" 8"
connection	ISO 7005 PN10 ANSI B16.5 - 150 RF
valve set	stainless steel, special alloy
body	ductile iron, stainless steel



RMG 937-E

RMG 937-E	
	pressure and vacuum vent deflagration
application	gas/air- or vapour/air-mixtures of the explosion groups: IIB3, IIA, I (methane)
nom. diameter	50 80 100 150 200 250 2" 3" 4" 6" 8" 10"
connection	ISO 7005 PN10 ANSI B16.5 - 150 RF
valve set	stainless steel, special alloy
body	ductile iron, stainless steel



RMG 937-P

RMG 937-P	
	pressure and vacuum vent deflagration and endurance burning
application	gas/air- or vapour/air-mixtures of the explosion groups: IIA, I (methane)
nom. diameter	50 2"
connection	ISO 7005 PN10 ANSI B16.5 - 150 RF
valve set	stainless steel, special alloy
body	ductile iron, stainless steel

End-of-line breather vent in accordance with ATEX 95 and EN13463-1, EN13463-5	explosion group	
	IIB (C) (MESG \geq 0.50)	IIA (D) (MESG > 0.90)
pressure vent	○	○
vacuum vent	○	○
pressure and vacuum vent	○	○



RMG 942-EV

RMG 942-EV (Emergency vent) pressure vent

application	gas/air- or vapour/air-mixtures: II 1/2 G c IIB T X					
nom. diameter	50	80	100	150	200	250
	2"	3"	4"	6"	8"	10"
connection	ISO 7005 PN10 ANSI B16.5 - 150 RF					
valve set	stainless steel, special alloy					
body	carbon steel, stainless steel					



RMG 943

RMG 943 Vacuum vent

application	gas/air- or vapour/air-mixtures: II 1/2 G c IIB T X				
nom. diameter	50	80	100	150	200
	2"	3"	4"	6"	8"
connection	ISO 7005 PN10 ANSI B16.5 - 150 RF				
valve set	stainless steel, special alloy				
body	ductile iron, stainless steel				



RMG 944

RMG 944 Pressure and vacuum vent

application	gas/air- or vapour/air-mixtures: II 1/2 G c IIB T X					
nom. diameter	50	80	100	150	200	250
	2"	3"	4"	6"	8"	10"
connection	ISO 7005 PN10 ANSI B16.5 - 150 RF					
valve set	stainless steel, special alloy					
body	ductile iron, stainless steel					

Grading of explosion groups

Explosion group		MESG ⁴⁾ of mixture	Example
IEC ¹⁾	NEC ²⁾	in mm	
I ³⁾		≥ 1.14	Methane
IIA	D	> 0.90	Fuel
IIB1	C	≥ 0.85	Ethanol
IIB2		≥ 0.75	Dimethyl ether
IIB3		≥ 0.65	Ethylene
IIB		≥ 0.50	Carbon monoxide
IIC	B	< 0.50	Hydrogen

¹⁾ IEC International Electric Code

²⁾ NEC National Electric Code

³⁾ in accordance with ISO 16852

Explosion group IIA1

⁴⁾ Maximum experimental safe gap (MESG):

Maximum gap of the joint between the two parts of the interior chambers of a test apparatus, which when the internal gas mixture is ignited under specific conditions, prevents ignition of the external gas mixture through a 25 mm long joint for all concentrations of the tested gas or vapor in air. The maximum experimental safe gap is a feature of the respective gas mixture (EN 1127-1:1997).

Selection of explosion group IIA (D) (*Substances in the explosion group I)

Gases	Liquids
Biogas	Acetaldehyde (C ₂ H ₄ O)
Butane (C ₄ H ₁₀)	Acetone (C ₃ H ₆ O)
Butene (C ₄ H ₈)	Acetonitrile (C ₂ H ₃ N)
Land-fill gas *	Formic acid (CH ₂ O ₂)
Natural gas	Ammonia (NH ₃)
Liquefied gas	Aniline (C ₆ H ₇ N)
Power gas (suction gas)	Benzol (C ₆ H ₆)
Furnace gas	Cumene (C ₉ H ₁₂)
Carbon oxysulphide (COS)	Dichloromethane (CH ₂ Cl ₂)
Digester gas *	Diesel fuel
Methane (CH ₄) *	Jet petrol
Methyl nitrite (CH ₃ NO ₂)	Petroleum (crude oils)
Monochlor difluorethane (C ₂ H ₃ ClF ₂)	Acetic acid (C ₂ H ₄ O ₂)
Propane (C ₃ H ₈)	Aviation fuel
Propene (C ₃ H ₆)	Methanol (CH ₄ O)
Trimethylamine (C ₃ H ₉ N)	Petrol Super
Vinyl chloride (C ₂ H ₃ Cl)	Petroleum
1,1,1-Trifluorethane (C ₂ H ₃ F ₃)	Vegetable oils (e.g. turpentine oil, pine oil)
	Solvent Naptha
	Special benzine (e.g. petrol-ether, mineral turpentine)
	Toluol (C ₇ H ₈)
	Trichlorethylene (C ₂ HCl ₃)
	Xylol (C ₈ H ₁₀)

Selection of explosion group IIB1-IIB (C)

Gases	Liquids
Butadiene -1,3 (C ₄ H ₆)	Oxobutanoic acid (C ₅ H ₈ O ₃)
Dimethyl ether (C ₂ H ₆ O)	Acrylonitrile (C ₃ H ₃ N)
Ethylene (C ₂ H ₄)	Cyclohexadiene -1,3 (C ₆ H ₈)
Ethylenoxide (C ₂ H ₄ O)	Diethyl carbonate (C ₅ H ₁₀ O ₃)
Formaldehyde (CH ₂ O)	Divinyl ether (C ₄ H ₆ O)
Carbon monoxide (CO)	Ethanol (C ₂ H ₆ O)
Coke oven gas	Ethyl benzol (C ₈ H ₁₀)
Hydrogen sulphide (H ₂ S)	Furan (C ₄ H ₄ O)
	Isoprene (C ₅ H ₈)
	Methacrylate (C ₄ H ₆ O ₂)
	Nitrobenzol (C ₆ H ₅ NO ₂)
	Propylenoxide (C ₃ H ₆ O)

Selection of explosion group IIC (B)

Gases	Liquids
Hydrogen (H ₂)	Carbon disulfide (CS ₂)

Explosion

Abrupt oxidation and decomposition reaction producing an increase in temperature, pressure or in both simultaneously (EN 1127-1:1997)

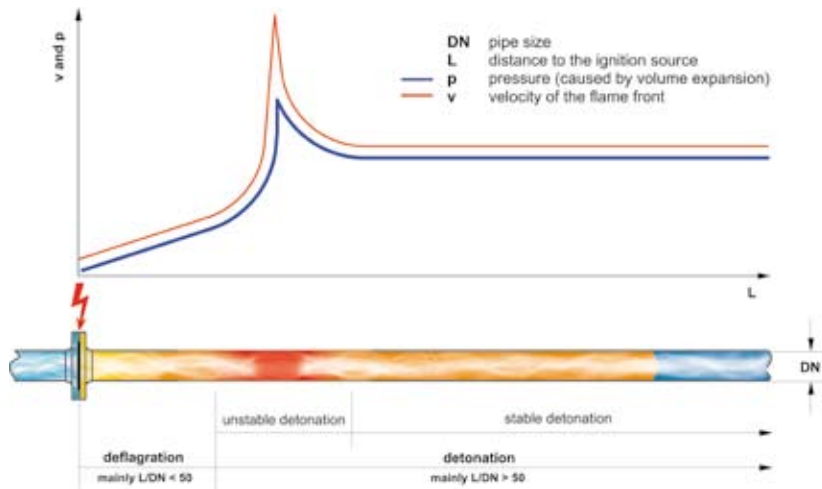

Combustion process in a pipeline

Deflagration

Explosion propagating at subsonic velocity (EN 1127-1:1997)

Detonation

Explosion propagating at supersonic velocity and characterized by a shock wave (EN 1127-1:1997)

Stable detonation

A detonation is stable if it progresses through a confined system without significant variation of velocity and pressure characteristics. (EN 12874:2001)

Unstable detonation

A detonation is unstable during the transition of a combustion process from a deflagration into a stable detonation. The transition occurs in a limited spatial zone where the velocity of the combustion wave is not constant and where the explosion pressure is significantly higher than in a stable detonation. (EN 12874:2001)

Explosive atmospheres

Mixture of air and inflammable gases, vapours, mists or dusts under atmospheric conditions in which the combustion process shifts to the entire unburnt mixture after successful combustion (EN 12874:2001)

Atmospheric conditions

Atmospheric conditions here include overall pressures of 0.8 bar to 1.1 bar and mixed temperatures of -20°C to +60°C. (EN 50284-12-1:2000)

Flame arrester

A safety device fitted to the opening of an enclosure or to the connecting pipework of a system of enclosures and whose intended function is to allow flow but prevent the transmission of flame (EN 12874:2001)

End-of-line flame arrester

A flame arrester which is fitted with only one pipe connection (EN12874:2001)

In-line flame arrester

A flame arrester which is fitted with two pipe connections, one on each side of the flame arrester element (EN 12874:2001)

Integrated temperature sensor

A temperature sensor to indicate a stabilized flame and integrated into the flame arrester by the manufacturer (EN 12874:2001)

Short time burning

Stabilized burning for a specified time (EN 12874:2001)

Endurance burning

Stabilized burning for an unspecified time (EN 12874:2001)

Venting of atmospheric and low pressure storage tanks

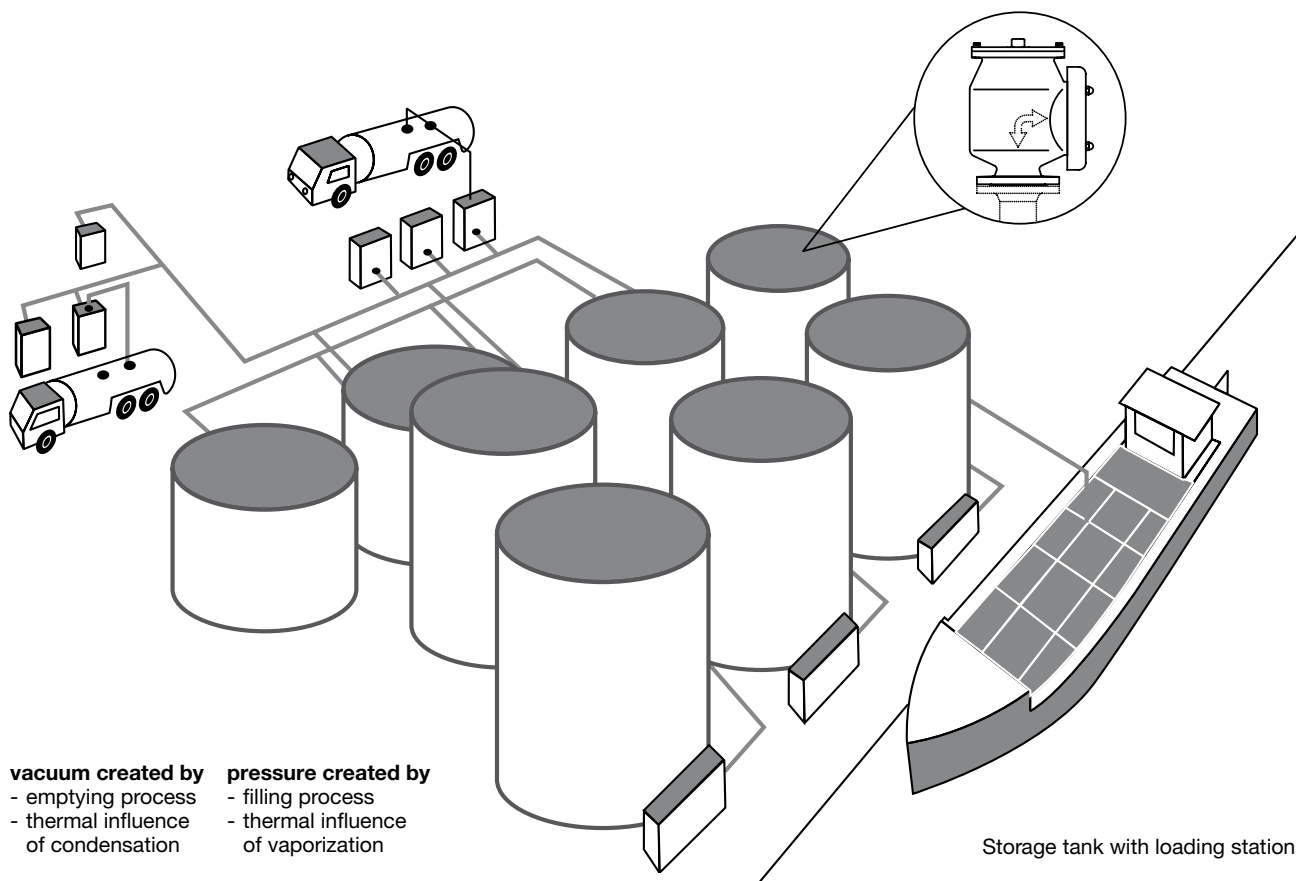

Normal venting	Is the ventilation necessitated by operational conditions or atmospheric changes
Emergency venting	Ventilation in case of tank equipment malfunctions or ventilation in case of fire
Filling rate	Maximum pump performance while filling the tank
Emptying rate	Maximum pump performance while emptying the tank
Thermal inbreathing	Introduction of air or deck gas in a tank during contraction or condensation of vapours in the tank resulting from atmospheric influences (e.g. decrease in the ambient temperature)
Thermal outbreathing	Discharge of air and vapour from a tank by expanding the air and vapour and vaporization of the liquid in the tank resulting from atmospheric influences (e.g. increase in the ambient temperature)
Additional facts	Dimension, design pressure and location of storage tank, type of stored products, insulation used
Set pressure	Pressure in which the valve starts to open under atmospheric conditions
Opening pressure	Pressure in which the valve achieves the lift fully open necessary for the volume flow to be discharged.

Note:
 For determining and selecting the suitable armatures, it is necessary to know at least the technical data. Depending on customer's requirement, standard confirmed design layout can be supplied in accordance with various standards.



CERTIFICATE



DQS GmbH
Deutsche Gesellschaft zur Zertifizierung von Managementsystemen

hereby certifies that the company

RMG-GASELAN Regel + Meßtechnik GmbH
Fürstenwalde

Julius-Pintsch-Ring 3
15517 Fürstenwalde
Germany

has implemented and maintains a **Quality Management System**

Scope:
Development, manufacturing, selling and maintenance of gas pressure regulating, safety devices, turning piston gas meters, filter and flame arrestors
Manufacturing and maintenance of systems for the gas pressure regulation and measurement of volume

Through an audit, documented in a report, it was verified that the management system fulfils the requirements of the following standard:

ISO 9001 : 2008

Certificate registration no.	002664 QM08	 TGA-ZM-02-90
Date of certification	2009-10-05	
Valid until	2012-10-04	

 Michael Drechsel
Managing Director

 Jan Bäge
Managing Director

August-Schurz-Strasse 21, 60433 Frankfurt am Main







Federal Institute for Materials Research and Testing
12205 Berlin, Germany
Phone: +49 30 8104-0
Fax: +49 30 8104-229
Internet: www.bam.de

PRODUCTION QUALITY ASSURANCE NOTIFICATION

- (1) **PRODUCTION QUALITY ASSURANCE NOTIFICATION**
- (2) **Equipment and Protective Systems or Components Intended for Use in Potentially Explosive Atmospheres**
Directive 94/9/EC
- (3) Notification Number: **BAM03ATEX Q001** 
2nd Revised Version
- (4) Equipment and Protective Systems or Components:
EC type-tested flame arresters with crimped metal foil flame arrester elements, with and without valve function, including valves without flame arrester
- (5) Applicant: **RMG Gaselan Regel + Meßtechnik GmbH, Julius-Pintsch-Ring 3, 15517 Fürstenwalde**
- (6) Manufacturer: **see Applicant**
- (7) The BAM Federal Institute for Materials Research and Testing (BAM Bundesanstalt für Materialforschung und -prüfung), notified body N° 0589 for Annex IV in accordance with article 9 of the Council Directive 94/9/EC of 23 March 1994 notifies to the applicant that the manufacturer has a production quality system which complies with the Annex IV of the Directive.
- (8) This notification is based on the audit report N° 15/2009 issued on 16 December 2009 and is valid until **19 December 2012**. This notification can be withdrawn if the manufacturer no longer satisfies the requirements of Annex IV.
The results of the re-certification audit are a part of this notification.
- (9) According to Article 10 (1) of the Directive 94/9/EC the CE marking shall be followed by the identification Number 0589 of BAM identifying the notified body involved in the production surveillance stage.
- (10) The EC type-examination certificates are listed in the Annex. The Annex is constituent part of this document.

BAM Federal Institute for Materials Research and Testing /
BAM Bundesanstalt für Materialforschung und -prüfung
D-12205 Berlin, 2009-12-20

 Dr. rer. nat. R. Schmidt
(BAM Certification Body)

 Dr.-Ing. J. Thiele: Dipl.-Ing. D. Amdt
(Assessors)

Distribution list: 1st Manufacturer 2nd BAM Certification Body

This notification may be published only in full wording and without any additions. For changed reproduction and extracts a revocable permission in writing has to be obtained from BAM. Translation for information purposes only. **erman Certificate is authoritative.**
www.bam.de

CERTIFICATE



conversion of pressure units

Einheit	N/cm ²	kPa	mbar	bar	mm Hg	mH ₂ O	kp/cm ²	atm	psi
N/cm ²	1	10	100	0,1	75,006	1,0197	0,10197	0,09869	1,45054
kPa	0,1	1	10	0,01	7,5006	0,10197	0,010197	0,009869	0,145045
mbar	0,01	0,1	1	0,001	0,75006	0,010197	0,0010197	0,0009869	0,014504
bar	10	100	1000	1	1750,06	10,197	1,0197	0,9869	14,504
mm Hg	0,013332	0,1332	1,3332	0,0013332	1	0,01360	0,001360	0,0013158	0,019337
mH ₂ O	0,9807	9,807	98,07	0,09807	73,55	1	0,1	0,09678	1,423
kp/cm ²	9,807	98,07	980,7	0,9807	735,5	10	1	0,9678	14,22
atm	10,132	101,325	1013,25	1,01325	760	10,332	1,0332	1	14,696
psi	0,6895	6,895	68,95	0,06895	51,71	0,7031	0,07031	0,06805	1

conversion of volume units

	m ³	cm ³	in ³	ft ³	yd ³	US fl oz	UK fl oz	US gal	UK gal	UK pint
1 m ³	1	10 ⁶	61024	35	1,3	33814	35195	264,2	219,9	1759,8
1 cm ³	10 ⁻⁶	1	0,061024			0,033814	0,035195			
1 cubic inch		16,3872	1			0,5541	0,5768			0,0288
1 cubic foot	0,0283168	28316,8	1728	1	0,03704	957,5	996,6	7,4805	6,2288	49,831
1 cubic yard	0,76456		46656	27	1			201,97	168,18	1345,43
1 US fluid ounce		29,574	1,805			1	1,041			
1 UK fluid ounce		28,413	1,7339			0,96075	1			0,05
1 US gallon		3785,4	231	0,1337		128	133,23	1	0,8327	6,662
1 UK gallon		4546,09	277,42	0,1605		153,72	160	1,201	1	8
1 UK pint		568,261	34,68	0,02		19,215	20	0,1501	0,125	1

conversion of longitude units

	m	km	in	ft	yd	stat. mile	n mile
1 m	1	0,001	39,3701	3,28084	1,09361		
1 km	1000	1	39370,1	3280,84	1093,61	0,621371	0,539957
1 inch (zoll)	0,0254		1	0,08333	0,02778		
1 foot (Fuß)	0,3048		12	1	0,3333	0,000189	
1 yard	0,9144		36	3	1	0,000568	
1 statute mile (Landmeile)	1609,344	1,609344	63360	5280	1760	1	0,868976
1 n mile (nautical mile)	1852	1,852	72960	6076,12	2025,37	1,15078	1
1 fathom = 6 ft = 1,8288 m; 1 mil = 0,001 in							

The information given in this brochure is only an excerpt from the entire thematic data. Since the data is complex, all essential details for describing flame arresters and valve have not been explained here. For queries related to our products, please use a questionnaire we have prepared for you. It includes the data required for correct installation of the device and needs to be completed by the customer. If you require any other information or have queries, please contact us using the details overleaf.

For more information

About RMG flame arresters and vents, please visit <http://hpsweb.honeywell.com> or contact one of our distributors.

Honeywell Process Solutions

RMG-GASELAN Regel + Messtechnik GmbH

Julius-Pintsch-Ring 3

D-15517 Fürstenwalde

Phone: +49 (0)3361 356-60

Fax: +49 (0)3361 356-836

E-mail: fds@rmg.com

<http://hpsweb.honeywell.com>



by Honeywell